

FLYING ACES

FACT
MODEL
BUILDING
FICTION

15

JUNE

FROM MODEL BUILDERS TO LUFTWAFFE
by CHARLES YERKOW



NORTHROPS FOR
THE NORSEMEN

"SMOKE GETS IN YOUR SKIES" • DIRIGIBLE FEATURE • "BEHIND FACTORY DOORS"
COFFIN KIRK AND TANK • ERIC TRENT AND MORT CRABB • PHINEAS LAFF FEST
MODELS: "STALL-PROOF GASSY" • PUSHER GLIDER • "IT'S THE FINISH THAT COUNTS"

Here It Is!

THE

FLAGSHIP

... by Scientific

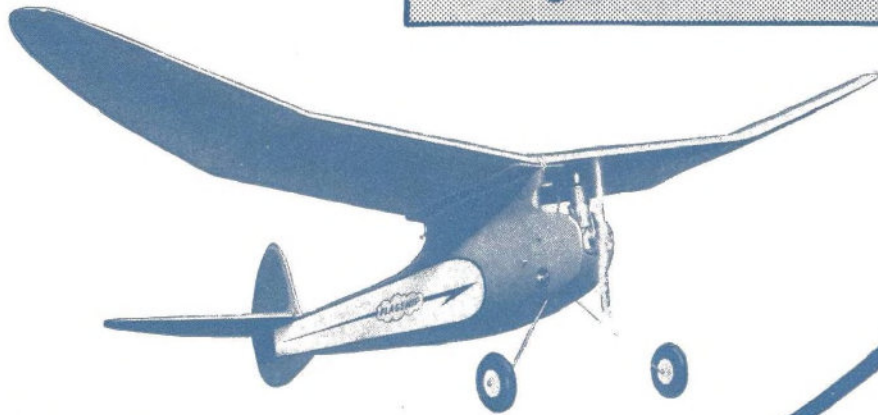

- ★ WINGSPAN . . . 78"
- ★ OVERALL LENGTH . . . 44½"
- ★ WING AREA . . . 850 Sq. In.
- ★ TOTAL WEIGHT . . . 3 lbs.
(with motor)

COMPLETE
KIT

4.95

POSTPAID
or at your dealer

The "FLAGSHIP" is the answer to a gas model builder's dream for a class "C" gas model that would be "TOPS" in beauty and performance, yet inexpensive too! Its sound aeronautical design, incorporating many new outstanding engineering features, gives it the climb of a rocket and the glide of a gull! Unequaled for stability and performance, the "FLAGSHIP" fulfills all the requirements of every model builder, and is eligible for A.M.A. contest rules.

Among its many features are: removable motor and ignition unit, especially constructed for easy mounting and unmounting of motor; battery box movable for weight adjustment.

Complete Kit, including explicit, full size plans, finished propeller, 3½" balsa wheels, Scientific colorless cement, scientific bamboo paper cement, red, white and blue bamboo paper, finished fasteners for mounting landing gear, all hardware and fittings required, printed balsa sheets cut to size, balsa strips, etc., complete . . . nothing else to buy . . . post paid or at your dealer . . . \$4.95

Send 5c for Scientific's Big Bargain Catalog

Scientific
MODEL AIRPLANE CO.

218-220 FA-6 Market St., Newark, N. J.

NEW No. 1 Scientific GLIDER

NEW! Wing Tapered . . . rudder, stabilizer and fuselage cut to shape! Wingspan—20¾". Length—18". **25c**



Scientific's LIGHTNING . . . 25c

One of the fastest flying models ever designed! Easy to build, too! Wingspan 25".

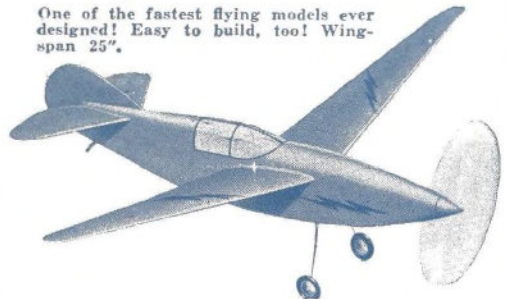

Scientific's BULLET . . . 50c

A pursuit type plane with a low, streamlined, tapered wing, and enclosed cabin. Wingspan—30".

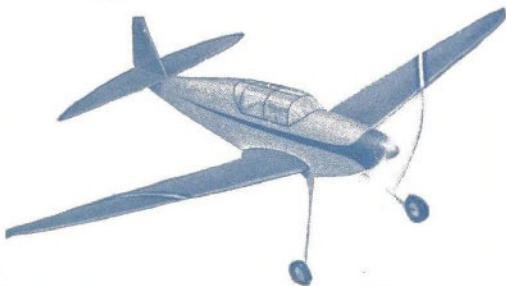

Train AT AVIATION'S SCHOOL OF THE HOUR!

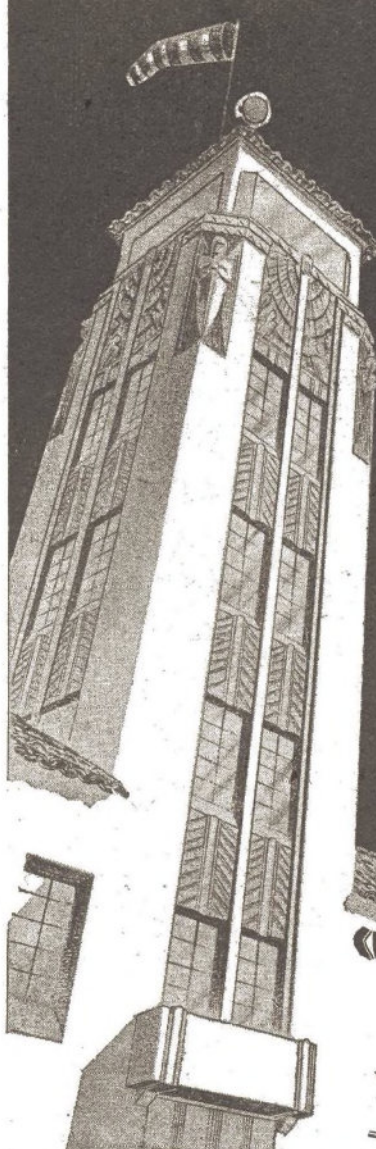

IN THE VERY CENTER AND A VERY IMPORTANT PART OF SOUTHERN CALIFORNIA'S GREAT AIRCRAFT INDUSTRY IS LOCATED CURTISS-WRIGHT TECHNICAL INSTITUTE.

Established in 1929, in twelve years this famous school has come to be recognized as the nation's leading institution in the training of Aeronautical Engineers and Master Mechanics. Mr. Donald Douglas, President of the great Douglas Aircraft Company, chose this school for his own son's training which pointedly indicates the high standing this school has attained in the aircraft industry.

You, who plan to invest in a course of career training to prepare yourself for the future, must determine in advance what the returns will be on your investment before you put cash on the line. This is imperative since your choice of a school in which to take your training will determine how much money you will make all the rest of your life. Your whole future in aviation depends on your training.

Curtiss-Wright Tec's career training is carefully designed to do just one thing:—TO MAKE MORE MONEY FOR YOU so upon graduation you can be independent and self-supporting for life. For years our hundreds of successful graduates have proven that Curtiss-Wright Tec training gets results and always pays. It has pro-

vided them with a profitable occupation and secure future since it trained them in advance for the highest position they could ever expect to occupy. it can do the same for you.

Aviation needs trained men. They are in demand and at a premium. Advancements for them are rapid, especially here in Southern California where there are over a billion dollars in unfilled aircraft orders on hand and where over fifty per cent of all aircraft manufactured in the United States is made. You can get in on the ground floor by training now, BUT you must choose the right school for your training.

Our graduates are obtaining immediate employment and the demand for them far exceeds the supply. We honestly believe that every student who enrolls here will be able to obtain, with our assistance, immediate employment upon graduation. This school has never guaranteed or promised positions for its graduates, but practically every graduate has obtained immediate employment, and is advancing steadily.

'WARNING!—"don't miss the boat." The greatest opportunity of your lifetime exists today! There never was such an opportunity in aviation for you; there may never be another. A position awaits you. Insure for yourself a steady income and independence for life. Send in your enrollment today before you "miss the boat."



OFFERING SPECIALIZED AND PROVEN TRAINING IN
AERONAUTICAL ENGINEERING
AND MASTER MECHANICS

No Flying Involved

THIS TOWER OVERLOOKS AVIATION'S MOST DISTINGUISHED SCHOOL OF AERONAUTICS

CURTISS  **WRIGHT**
TECHNICAL **INSTITUTE**

GRAND CENTRAL AIR TERMINAL 1227 AIRWAY GLENDALE (LOS ANGELES) CALIF.
UNDER PERSONAL SUPERVISION OF MAJOR G. C. MOSELEY, OWNER, SINCE ITS ESTABLISHMENT IN 1929

Contractor to the U. S. Army Air Corps

BE WISE—PROTECT YOUR FUTURE

MAIL TODAY

WITHOUT COST OR OBLIGATION
SEND ME FULL INFORMATION
AND CATALOG ON THE
COURSE CHECKED BELOW

DON'T DELAY

- AERONAUTICAL ENGINEERING COURSE
- MASTER AVIATION MECHANIC COURSE
- SPECIALIZED ENGINE COURSE
- SPECIALIZED AIRPLANE COURSE
- POST GRADUATE AERONAUTICAL ENGINEERING COURSE
- SPECIALIZED AIRCRAFT SHEET METAL COURSE
- AERONAUTICAL DRAFTING COURSE, HOME STUDY
- AIRCRAFT BLUE PRINT READING COURSE, HOME STUDY

NAME _____

ADDRESS _____

CITY _____

STATE _____

Sperry Gyroscope's blue and silver Lockheed 14 is used as a flying laboratory for testing new-type instruments.

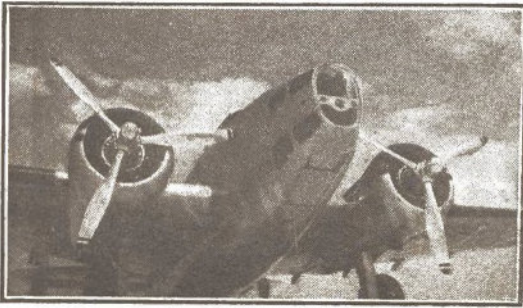

Did You Ever

stand looking up at skywriters as they spelled out words and phrases with their "aerial ink" and wonder how they work? Well, on page 10 we've got the complete, low-down story on those high-flying pilots—plus history on the business.

FLYING ACES

A. A. WYN, *Editor*

DAVID C. COOKE, *Managing Editor*

VOLUME XXXVIII

JUNE, 1941

NUMBER 3

FACT AND FICTION

FROM MODEL BUILDERS TO LUFTWAFFE	Charles Yerkow	4
Full information on how the German Air Force expanded.		
SMOKE GETS IN YOUR SKIES	Jesse Davidson	10
Skywriting pilots work on Heaven's ground floor!		
LURE OF THE LIBERATORS	Donald E. Keyhoe	14
Two men had been killed—and Trent and Crabb were next!		
WE NEED AERIAL AIRCRAFT CARRIERS!	W. H. Randall	20
Our coasts could be protected better with dirigibles.		
SELF-SEAL GAS TANKS	John F. Hicks	22
Flaming fuel tanks will now be few in war.		
THAT CUBAN "GOOD-WILL" FLIGHT	Douglas Clifton	23
Three flyers from Havana cover 12,000 miles.		
FATE FLIES THE BREDA	Arch Whitehouse	26
Just a little red can—but it caused plenty of trouble!		
BEHIND FACTORY DOORS	Frank Mackay	30
The reason planes cannot be built like automobiles.		
ME. FAME—FACT OR FANCY?	J. B. Rust	33
Germany's famed fighter dissected and inspected.		
JERRY PRISON SCAMP	Joe Archibald	34
Phineas goes Bugattis in the belfry!		
HOBBY BECOMES CAREER!	Robert E. Moore	60
How a modeler became a successful manufacturer.		

MODEL MAKING

WITH THE MODEL BUILDERS		41
STALL-PROOF GASSY	Robert Hayos	42
IT'S THE FINISH THAT COUNTS	Frances Savarese	46
TABLE TOP AERODROME	Harry Losin	47
OUTDOOR PUSHER GLIDER	Eddie Shane	48
NEWS OF THE MODELERS		50
CONTEST CALENDAR		50
IGNITION—AND HOW IT WORKS	Thracys Petrides	52
AERONCA PROFILE FLYER	Rex Hall	53
YOU SAID IT!		56
LOGGING THE MOTOR MARKET		56
WORKBENCH TIPS		57

DEPARTMENTS AND FEATURES

FLYING INTO FOCUS	8	IN THE SLIPSTREAM	32
DOWN MEMORY'S RUNWAY	13	JOIN THE FLYING ACES CLUB	37
MODERN PLANES ALBUM	18	FLYING ACES CLUB NEWS	38
ON THE LIGHT PLANE TARMAC	24	ALL QUESTIONS, ANSWERED	40
KNOW AMERICA'S PLANES	29	IN OUR NEXT ISSUE	57

Cover Painting by August Schomburg

Published monthly by Magazine Publishers, Inc.; office of publication, 29 Worthington St., Springfield, Mass. A. A. Wyn, President, Editorial and executive offices, 67 W. 44th St., New York. Entered as second-class matter, Nov. 14, 1928, at Springfield, Mass., under Act of March 3, 1879. Title registered in U. S. Patent Office. Copyright, 1941 by Magazine Publishers, Inc. Nothing may be reprinted without permission of the publishers. Manuscripts will be handled with care, but this magazine assumes no responsibility for their safety.

For advertising rates address FLYING ACES Magazine, 67 W. 44th St., New York City.
Subscription rate: \$1.50 for twelve issues in the United States, \$1.75 in Canada; and \$2.50 in all other foreign countries. Single copies, fifteen cents.



Take YOUR Place in Aviation
Beside these fellows



They Are Building Famous Fighting Planes

Yes, these fellows are experiencing the undeniable thrill of seeing great fighting planes take shape right before their own eyes, right under their own hands. But what is far more important, they are ALSO building substantial futures for themselves in Aviation.

These are Aero ITI-trained men. Hundreds more fellow graduates from Aero ITI engineering and mechanics courses are throughout the Aviation industry—with aircraft plants, air lines, the military services, accessory manufacturers... all divisions of the industry.

You would be proud to step into aircraft work beside Aero ITI men—with their same proven training behind you. You would be proud to have won the technical knowledge and practical ability Aero Industries Technical Institute demands

that its graduates possess—to assure a *sound* start in Aviation. You would be confident, too, of your broad, thorough training as a means of steady advancement in a great and growing industry.

The hundreds of Aero ITI graduates now making good in Aviation profited immediately from their Aero ITI training because it won them a start in Aviation... will continue to profit *far more* because of the ability it gave them to shoulder more and more important duties.

You can't afford any other kind of preparation for an Aviation career—if you want a sound start, security, advancement, and success. You must be sure you get the *right* training. Investigate the proven Aero ITI way to an Aviation career. Send the coupon NOW.

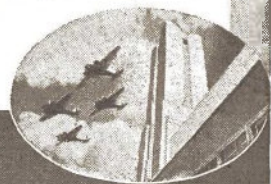

AERO INDUSTRIES TECHNICAL INSTITUTE

5266 WEST SAN FERNANDO ROAD · · · · · LOS ANGELES, CALIFORNIA

AERO INDUSTRIES TECHNICAL INSTITUTE
5266 West San Fernando Road, Los Angeles, California

Please send information on Aero ITI training for Aviation careers. I am interested in the following branch of Aviation: Aircraft Mechanics; Aeronautical Engineering; Undecided, please send more information. Years High School: 1, 2, 3, 4. Years College (Liberal Arts): 1, 2, 3, 4. Years Engineering College: 1, 2, 3, 4.

Name _____ Age _____

Address _____

City _____ State _____ a-17-FA

Five Courses in
AIRCRAFT MECHANICS and AERONAUTICAL ENGINEERING

—Including 12 Month Aircraft Mechanics Course
Approved by U. S. Civil Aeronautics Administration

ADVISORY BOARD

ROBERT E. GROSS
President, Lockheed
Aircraft Corporation

JOHN K. NORTHROP
President, Northrop
Aircraft, Inc.

C. A. VAN DUSEN
Vice-Pres., Consolidated
Aircraft Corporation



Regimentation in the Reich. This photo was taken back in 1935, and now many of these boys are probably being trained as pilots.

FROM MODEL BUILDERS

THE UNCERTAINTY of what will happen in the final showdown between the European airpowers has caused our own United States to plan and begin its tremendous defense program. The most important part of this program is the training of men—particularly the training of pilots.

All of us who are air-minded look ahead to see what will happen next. Will the U.S. be able to train thousands of first-class pilots? And once trained, will we be able to use them?

There is no definite answer to such questions as these.

But from where we sit it is apparent that the European war will be greatly decided through air hitting-power. And as no airpower can exist without trained pilots it would be proper at this stage to consider the manner in which the German Air Force personnel has been trained.

People hear or read about the vast German air armadas attacking Britain day in and day out, and they wonder how Hitler was able to gather so many able pilots for the job. German ships are shot down every day, which

means that at least one pilot is captured or killed per plane. And as if the whole thing did not matter in the least, more and more first-class Nazi pilots seemed to be growing in Germany.

The first point to bear in mind is the fact that Hitler is waging an offensive war. Offensive warfare must be planned minutely; if any thrust bogs down, if anything at all goes wrong, the leeway in the entire preparations much be such as to afford quick and efficient changes. Only one



The Treaty of Versailles stipulated that the Germans were not to have military airplanes. The Nazis prepared for their air force, however, by training pilots on gliders and soarers.

thing could accomplish this: a highly mechanized force—swift-moving, hard-hitting, powerful, versatile and expertly manned. The major portion of this mechanized force is the air unit.

HITLER knew what would win his wars for him. With all political acrobatics eliminated from his government, he handed the entire creation of a powerful Air Force to Field Marshal Hermann Goering who chose Ernst Udet to conduct all the research and technical ends.

All indications are that the people of the world imagine that the German Air Force did not come into being until Hitler's rise to power, which would say that the German

Luftwaffe was started sometime in 1933. However, this is not so, even though the official naming of the Air Force may have been made at that or even a later period. Actually, to go by brass tacks, the real and true start of what was to become the German Air Force was made around the middle of 1920. Yes—it was thirteen years in the making!

In other words, by the time Hitler stepped forth in 1933 to accept the Chancellery he had the embryo of his air force.

How this came about is not unusual and almost any aero follower might have guessed it. When people are forbidden to fly they will eventually turn to something which equals flying. The British, after the close of the first World War, did not actually forbid the Germans to fly, but they did turn thumbs down on the maintenance of any air force. The German youth could not help hearing and reading about the heroic deeds of such German pilots as Boelke, Richthofen, Immelmann and others, and it is little wonder that they sought an equally romantic vent for their feelings. But there were very few planes in Germany.

Then, in 1920, two closely related aviation activities sprung into being: model airplanes and gliders.

And there you have the whole start of today's German Air Force. Britain would not allow the manufacture of any sort of powered machines, therefore Britain surely could find no fault with model planes and

Nazi Germany has built up an Air Force of tens of thousands of pilots in comparatively little time, and most of these war flyers started in aviation under the intensive "Jungvolk" plan.

by Charles Yerkow

TO LUFTWAFFE



An instructor explains how the rear surfaces operate. Flyers were turned out in mass production to build up the present Luftwaffe.

gliders. Britain didn't, of course.

Model airplane building and flying was so enthusiastically received by the German youth that it did not take long before it was an accepted part of school hours. Boys from 6 to 16 took to the new introduction with sincerity, and soon they were learning about airfoils, thrust, drag, the structure of the model fuselage, wings, tail surfaces, etc.

Then would come the day of days—flying the models which they had been so careful in constructing. These flying meets occurred at regular intervals to keep interest alive in this new field.

Today, in 1941, the very same system prevails, by which German youth is subtly introduced to the technical side of warplanes and the theory of flight with the use of models.

But to keep to our tracks, let us remain with the year of 1920, when the second aviation activity engrossed all those boys who had been through the model building stage and were eagerly looking for something more intricate and more romantic, which they found in gliding and soaring.

It may be of interest for some to know that long before Hitler began his demands for the corridor of Danzig, the number of Ger-

With photos in barracks, Nazi airmen are constantly reminded of deeds performed by German aces in the great World War.

man gliding and soaring pilots was well in 200,000. Gliding and soaring was carried on under government supervision and on government funds. This after 1933. Prior to this date, in the years beginning with 1920, gliding and soaring was taken as a hobby, as was model plane building and flying—but, all in all, the trend was indeed a very profitable one for Germany. From the vast numbers of glider-trained pilots the government was able to draw its personnel for the slowly-blooming air force. By 1936, Germany had her "sport" flying clubs operating on a large scale.

LET SOME become confused or misinterpret the statements made in regard to the creation of the German Air Force, reconsider the glider-pilot angle as presented here. It does not mean that a glider-pilot can be merely seated into a high powered military plane and be expected to fly it. The cockpit of any military plane is earned through a gradually rising stairway which begins with primary trainers, follows through to advanced types, tapers off on specialized flight training, and may only then end in a check-out flight where 1,200 h.p. engines are concerned. But let this much be said about the glider-pilot who approaches military flight training: a glider-pilot, and particularly a soaring pilot, has the real fundamental needs of flying all stored away in his fine touch on the controls; he is most likely familiar with aerial navigation and meteorology. When pilots such as these are put through a power-flying course they take to it without difficulty. As a matter of fact, there are many first-class power-pilots who have often wished they'd had some soaring experience to make for better "air feel."

All this is a mere summing-up of the order in which German youth took to the air. And though up to 1933 it may not have been the intention or aim to train the youth for military duty, this very same aim was self-evident after that year.

The task of creating a powerful air force fell to Hitler's friend, Hermann Goering, who, as already stated, in turn appointed Ernst Udet as





Modelers showing ability and real interest were inducted into the Air Force when old enough for rigid military flight instruction.

very nearly the head of the whole show. Without the slightest waste in time and motion the lesser officials sorted out all those who were in the least familiar with flying, and into this category came some old-time World War pilots. There was a psychological reason for this: it made the youngsters look up to the older pilots who could still hold their own behind the stick. What is more important, and a factor which the Germans did not overlook, is that it proved to them that age limits were not to be standardized.

In short, anybody who could take a glider or a sport plane off the ground and set it down again was quite eagerly sought and asked to join the Air Force, regardless of age or education. Germany could not afford standardization of pilot personnel, for such steps would have dragged out her entire program and in all probability would have given them a far smaller number of men to work with. Standardization is necessary if mass production of aircraft is to be achieved, and Germany followed this rule within common sense reasons, but such standardization would have hampered them where pilot personnel was concerned.

Had the German official posted some such request as: "We want young men between the ages of 19 and 26, who have had at least two years of college, for our pilot-train-

ing program" it is anybody's guess what the results might have been. It certainly would not have made for a lightning stroke in the creation of an air force.

All this proves that whether a person is 16, 26, or 36, he is still good material for flight training—if you are serious about your efforts at creating an air force second-to-none and without a peer.

Some of our American self-elected experts will not agree with this contention nor with many of the facts set forth here. These experts have told us time after time that

It is in the records how school teachers throughout Germany made reports to the government concerning those boys who showed marked interest in model plane building and flying. The same procedure followed when the boy took to gliding. Thereafter, the government stepped in and literally threw the rest of the aviation career into the boy's lap, free of charge. No more skimping to buy flying hours! No more worry about the next textbook to buy! A training for which the boy craved being given free! You do not bite the hand that helps you. Is it any wonder, then, that German pilots in the present war are the ideal type for blitzkrieg methods?

So much for the German Air Force. Let's shift our binoculars to our own United States and get a glimpse of the pilot-training programs going on here.

IN THE FIRST PLACE, remember that the creation of any air force in the U.S. is the work of politicians and never the work of true aviation experts. An aviation expert may be called in for a conference but it is seldom that his advice, his suggestions, and his warnings are accepted

Under the "Jungvolk" Plan, boys from 6 to 16 were given lessons in model airplane building. In this fashion, Germany was able to interest quantities of potential pilot material in aviation at a young age.



the average German combat pilot is far below par, too young in years, too lacking in practical experience.

Consider—

A German boy of 16 or 17 is taught to fly a low-powered sport plane in 1934. If we are at all familiar with German efficiency we know that in a few years the same boy might have logged 500 or more flying hours, the last 100 hours perhaps being got in high-powered military type ships. Thus, by 1939 the boy was around his 21st or 22nd birthday and practically the equal of any average combat pilot in any air force.

and used. Whatever he may have to say regarding plane production, methods, or pilot-training systems will go into files and at a later date will be compared with suggestions made by some senator or other politician.

At the beginning of this article we said that Hitler was able to create the German Air Force only by snuffing out all political acrobatics. We, however, are being sorely hampered in our national defense preparations by these boondoggling methods.

The creation of a powerful U.S. Air Force falls primarily to three

bodies: Army, Navy, and the Civil Aeronautics Board. We can understand to an extent the Army and Navy stipulating age limits and educational requirements, but we can't understand them where the CAA is concerned. A great deal has been said and written about this college and non-college business (recently, the editors of one of our largest national magazines wrote me and stated that they thought the Government was not utilizing the full possibilities of the military pilot supply sources) yet our CAA, which should take into

cants. Only those are accepted who are between 19 and 26 years of age. That is quite in parallel with Army and Navy requirements, and so does not make it at all ideal as a civil ruling. What is wrong with youngsters 16, 17, and 18 years of age? And on the other extreme, those who are between 27 and 35?

Whether the Government will take steps to correct these glaring inconsistencies remains to be seen. Under a greatly revised program, which would not affect the quality of airmanship, many high school graduates

"Give me a half hour in the air with any student," said one flight instructor, "and I'll tell you how good a flyer he'll be." Another said: "If a man starts in by telling me he's a college graduate I am inclined to resent him. He makes me feel that I should respect his four years of schooling and overlook the man."

Where the U.S. is attempting to build an air force second-to-none, these facts should not be overlooked. A responsible few in Governmental offices recognize the need of a better and faster pilot-training system. Efforts are being made in the right direction, though they may take time to materialize. Only when the standardized pattern of "are you between 19 and 26 and have you two years of college?" is discarded will the American youth get a real chance to show the world how an air force second-to-none can come into being.

There is only one thing wrong. Unless our glider and light plane pilots and holders of Private Pilot licenses do not fall within the CAA standardized pattern they must struggle on with their flying the best way they can. Perhaps by saying that Hitler's CAA would never permit such waste of pilot possibilities, we might cause our rule-makers to wake up.

THE END

Germany has much territory excellently suited for good soaring. It was natural and profitable for them to turn to this so-called "sport."

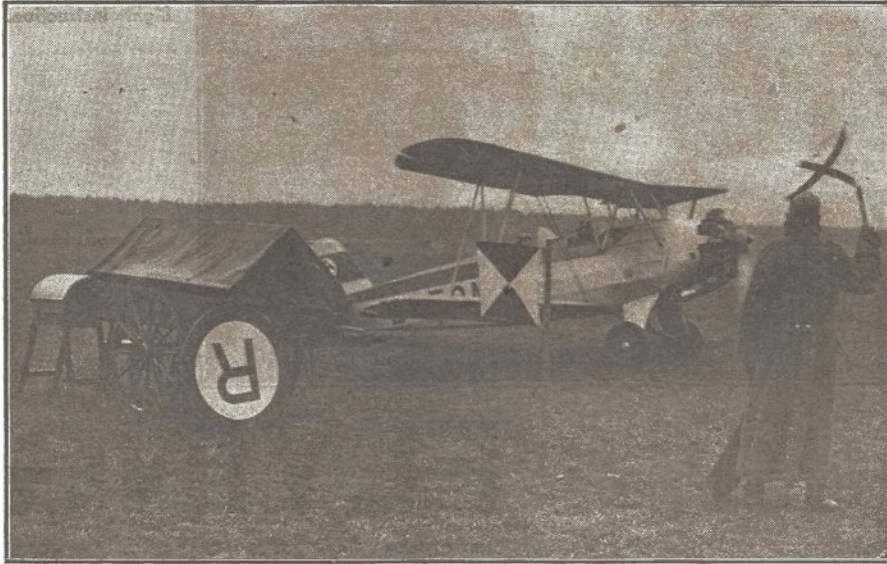

Flying fields were so busy with training craft before the War that it was necessary to have a field man to signal for take-offs and landings. Nazi student pictured here is going up for cross-country dual work.

consideration that it is engaged in civil aviation, makes practically the same stipulations and requirements as those effecting officer-personnel entering Army and Navy flying schools!

As a matter of record, there is the actual case of some eight college men who completed their flying course under the CAA program and who, upon graduation, were asked what they intended to do now that they had their licenses. The answer is enough to floor any flying man. Six of these pilots had no real interest in aviation—they liked the idea of free training but were not the least bit interested in keeping up their flying time. The remaining two "thought" they would keep on flying.

Time after time big-name pilots have made statements which boiled down to the contention that college men do not necessarily make good pilots. However, it appears that rule-makers imagine a non-college man as too stupid to be able to differentiate between throttle and rudder pedals.

It is surprising that this sort of standardization goes on and no one seems to notice that it is hindering the maximum efficiency through which an air force second-to-none could be developed. Besides educational standardization, the CAA has even gone a step back and has imposed an age limit on would-be appli-

would get their chance at flight training under the CAA program, as would those who at the present do not fall within the age limits.

As it stands, our American youth has to fight for its chances at any specialized training. If the youngster can afford it, all's well and fine; if he can't—it's just too bad. This naturally places all the applicants for the free flying course under the CAA on a sort of competitive basis, by which the CAA has the choice of the cream which, too, may be all right but against which too many important figures in the aviation world have voiced their disapproval.



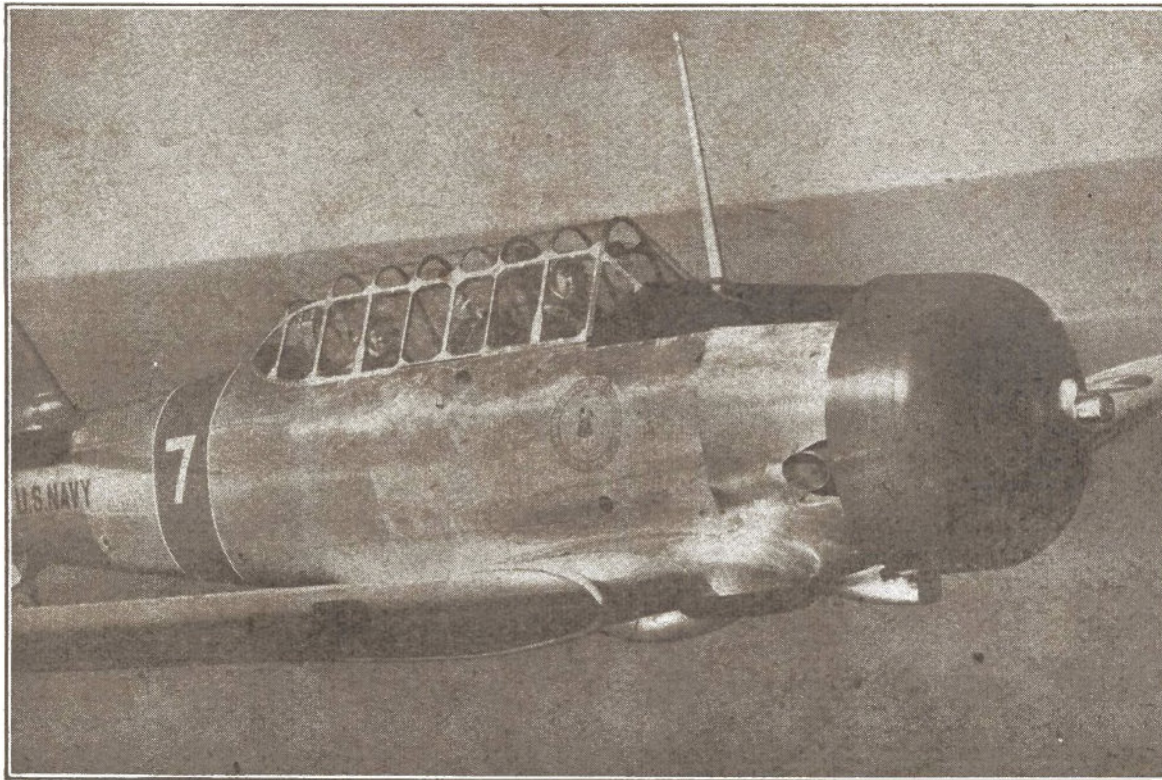

Here's a remarkable close-up flight shot of the Navy's new North American SNJ-1 scout-trainer. At the controls is Comdr. Don F. Smith, Commanding Officer of the U. S. Aviation Base at Floyd Bennett Field. Powered with a 650-h.p. Pratt & Whitney engine, the SNJ cruises at about 160 and is excellent for student flight instruction.

Below: Ready for immediate action in the Far East. The first group of an undisclosed number of Curtiss Hawk 75A fighters of the Royal Netherlands East Indies Air Force on the line at the big Bandoeng, Java, airdrome Japan, watch your step!

FLYING

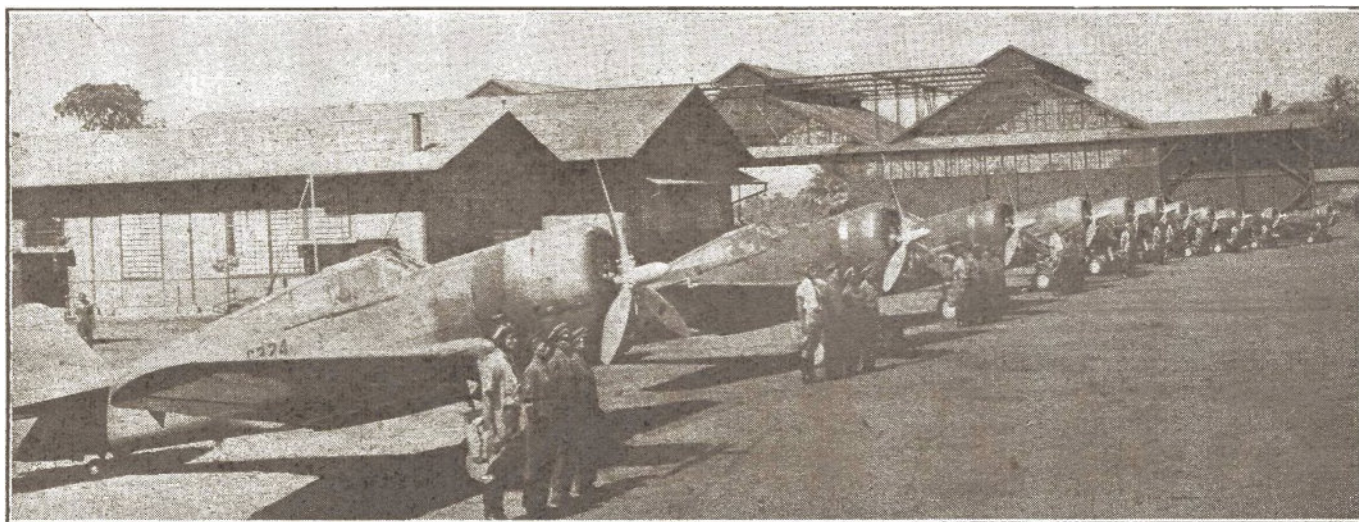

Mass output of Curtiss airplanes now averages a new all-time record of 10 daily. Half are for the U.S., half for Britain.

Power transformers for Douglas' new blackout factory are being constructed underground. Idea is: Out of sight, out of harm.

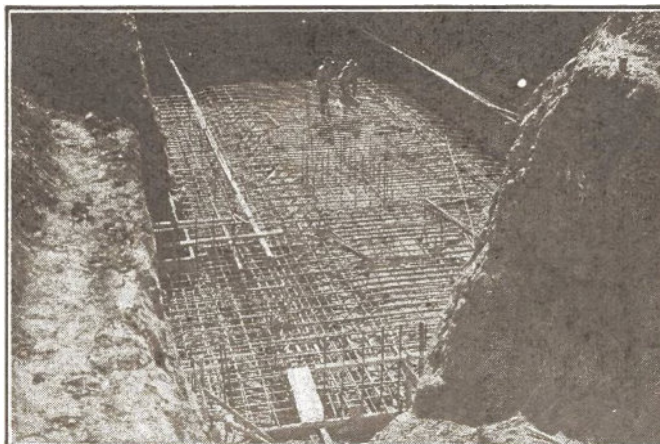

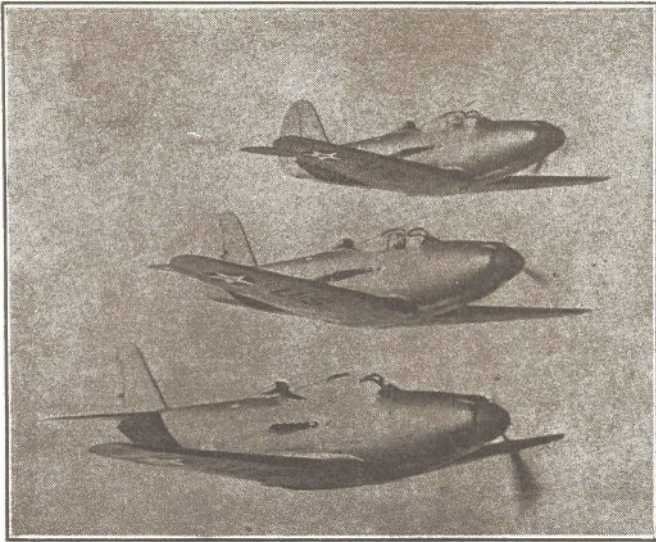

Although the three Army airmen flying these Airacobras had never seen the ship before, they had no difficulty handling them. Tightness of formation testifies fact.

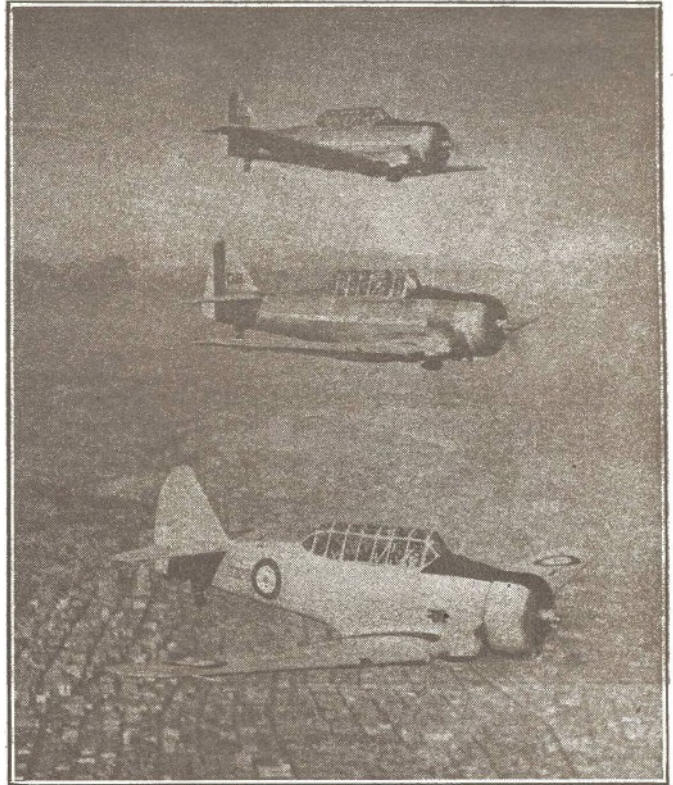

Right: Aerial view of three N.A.'s during test flights over Los Angeles. In foreground is Harvard for R.A.F. and in background are two light attack bombers for Brazil.

INTO FOCUS



One type for four countries. Lined up in front of the Stearman plant are machines for Air Corps, Brazil, Cuba, and Venezuela.



Crew quarters of Douglas B-18A bomber has just one folding cot. Below this compartment is bay where racks for bombs are located.

A group of British Boeing B-17C's at Vancouver, B. C. Streamlined blisters have been removed and in their stead are gun ports flush with fuselage sides. These ships are flown to Great Britain.

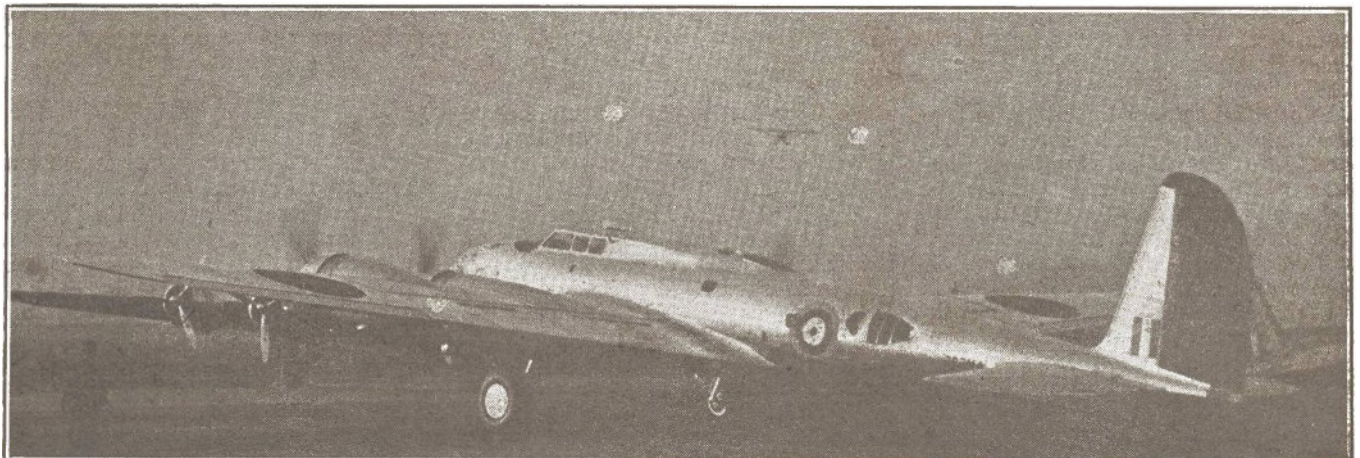



When the American Legion held its New York City convention in 1937, skywriting was attempted at night for the first time. Andy Stinis flew at 16,000 feet to make the sign.

Smoke Gets in Your Skies

NEW YORKERS have become accustomed to the aerial gymnastics of skywriters, and they've taken it for granted as only a New Yorker can take a thing for granted. But this writer wanted to find out the low-down on these high-flying airmen, so it was straight for Floyd Bennett airport, where the country's ace skywriting ships and "flying penmen" are hangared.

It was a cold day and sections of the sky were overcast. Toward the west a huge clear blue spot seemed to hang stationary, but in reality it was very slowly drifting toward midtown Manhattan. Andy Stinis and Tom Murphy were sitting in their cubby-hole office, feet on desks, waiting for a good-sized patch of clear "blue stuff." Evening was drawing closer and they squirmed uneasily in their seats, hopeful that they might get a crack at it before nightfall drew its blinds.

Pilot Stinis stepped out to scan the skies, and a moment later he dashed back into the office. Suddenly, he flung a heavy leather jacket, parachute, and helmet and goggles to me. "Get into these duds, fella, and make it fast. Here's that chance you've been waiting for all day!"

I felt like a sack of potatoes as both pilots helped to dump me into the front cockpit of Stinis' Wright-powered Waco. Once in and strapped, I was cautioned to resist the temptation to handle the extra set of controls and let Andy do the back-seat

Have you ever wondered how those aerial Palmer Method experts carry out their penmanship? Here we take you behind the scenes for the absolute low-down on those high-flying sign painters.

by Jesse Davidson

driving. Mechanics chocked the wheels of both ships and the engines were kicked to life. And when the Waco's engine temperature gauge registered 180 degrees, Stinis waved the all ready signal to "Murph" in the Travelaire.

Stinis led out to the end of the long runway and swung around into the wind. A jazz of the powerful engine echoed satisfaction to his ear, and he gave the blue and gold ship full gun. A muffled rumbling of the wheels and then, suddenly, plenty of clean white space. I turned to look for the Travelaire. There it was, about fifty feet to the left and slightly below. Murphy was grinning; he loves his work and welcomes every opportunity to "pour the ink."

A puff of white "ink" spurted out from between the undercarriage of the rakish-looking Travelaire. Both pilots observed its density and drift. It hung together, and that meant the air was calm—so far.

By prearranged signals, both ships swung away in an arc at an astonishing rate of speed. With noses pulled up higher and throttles wide open, we climbed to 12,000 feet, where the

"writing blackboard" seemed to be cleanest.

I glanced at my wrist watch and noted it was 6:10 p. m. Above, the sky grew clearer and large patches of blue became more frequent. The spot we were headed for stretched over midtown and extended clear up to Yonkers. The boys would have to work fast. Their assignment for that day was the same as it had been for many months—a long standing contract to write the I. J. FOX FINE FURS inscription on any and every clear day skywriting was possible.

WE REACHED the 12,000 foot mark in short order as these little ships fly with engines wide open from the moment of take-off.

There were no ceremonies before going into their maneuvers and I was conscious of the actual writing only when the Travelaire flashed past us with white smoke trailing behind. It looked as if Murphy were being chased as the voluminous smoke purred out at the rate of 250,000 cubic feet per second. His plane zoomed sharply after completing the simple letter "I." Stinis swung into

position and began spouting a stream tracing out a neat "J." Just as he tapered off, Murphy ran out the long stem of the "F" while Stinis climbed a hundred feet higher and added the short horizontal stroke, ending neatly at right angles to the upper end.

Perfect timing and split-second accuracy are required to abruptly "shut off" the smoke where the horizontal line meets the vertical, or vice versa. Stinis swung around into the clear again and trailed a short stroke to hang the center bar in place to complete the letter "F." Later, when we had a chance to look over the work, I noticed he ended that center stroke almost to the inch the length of the top bar.

As Stinis shut off and pulled up, Murphy piloted his glistening ship in and out of a perfectly executed circle making the letter "O." A split-second later, Andy shot an angle-wise bar of aerial ink across the sky, and as he tapered off Murphy criss-crossed the angled white trail right smack in its middle to make the "X."

Murphy and Stinis again lined themselves up to knock off another "F." Since the following three letters were to be done in script, it remained a one-man job this time and Andy went into it alone. Murphy streaked out a long way off to plaster his section of the ethereal billboard with the word "Furs."

The system of each pilot doing a word apiece isn't as spectacular as when they do a script "dual." This is one where one pilot tacks on the letter "R" to "U" just as the one who wrote "R" hangs a neat "S" onto "U" so expertly that it looks as if it were done by only one writer. But on this day time was short, and it was evident Mr. I. J. Fox would not have felt so fine if the sky wasn't cloaked with his furs. So they hurried to get the message through.

Andy lined up his aero eye as best

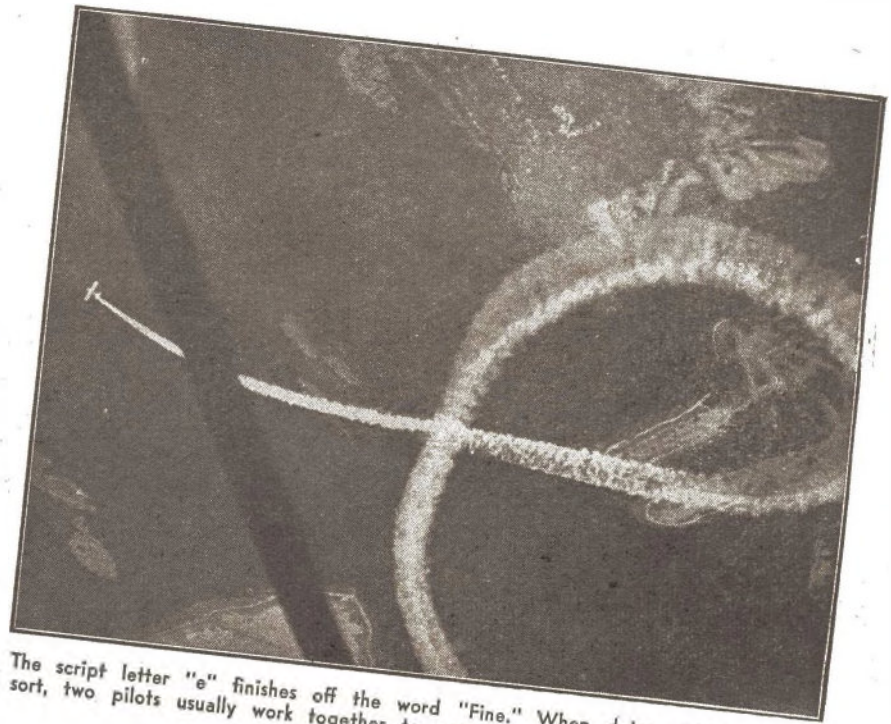

The script letter "e" finishes off the word "Fine." When doing writing of this sort, two pilots usually work together to prevent drift from ruining their work.

he could and "goosed" a short burst to dot the "I" which followed instantly. Then he began a series of banks and turns, displaying a perfect sample of penmanship that would do Palmer's heart much good. In order to keep the letters approximately the same size and to leave more or less equal spacing between them, a constant speed is maintained and the engine revs are closely watched. But after six years of this, Andy went through the simple gyrations as easily as a pastry baker manipulates his icing bag over the surface of a birthday cake.

While Stinis was absorbed in his spider web tactics, Murphy was some-

where over Van Cortland Park doing the same thing. The amazing thing about this team-work is that they finish their respective jobs almost simultaneously, with the complete aerial advertisement extending clear across Manhattan and covering a distance of almost fifteen miles.

The assignment finished, Stinis banged hard on the cockpit cowl to attract my attention. He motioned downward as he put the ship in a coasting position. From out of nowhere, Murphy drew up alongside, almost brushing wing tips and grinning like a well-fed cat. A thousand feet below, the ships broke away as Stinis motioned for me to look up-

Andy Stinis flies his Waco at top speed when making aerial signboards.

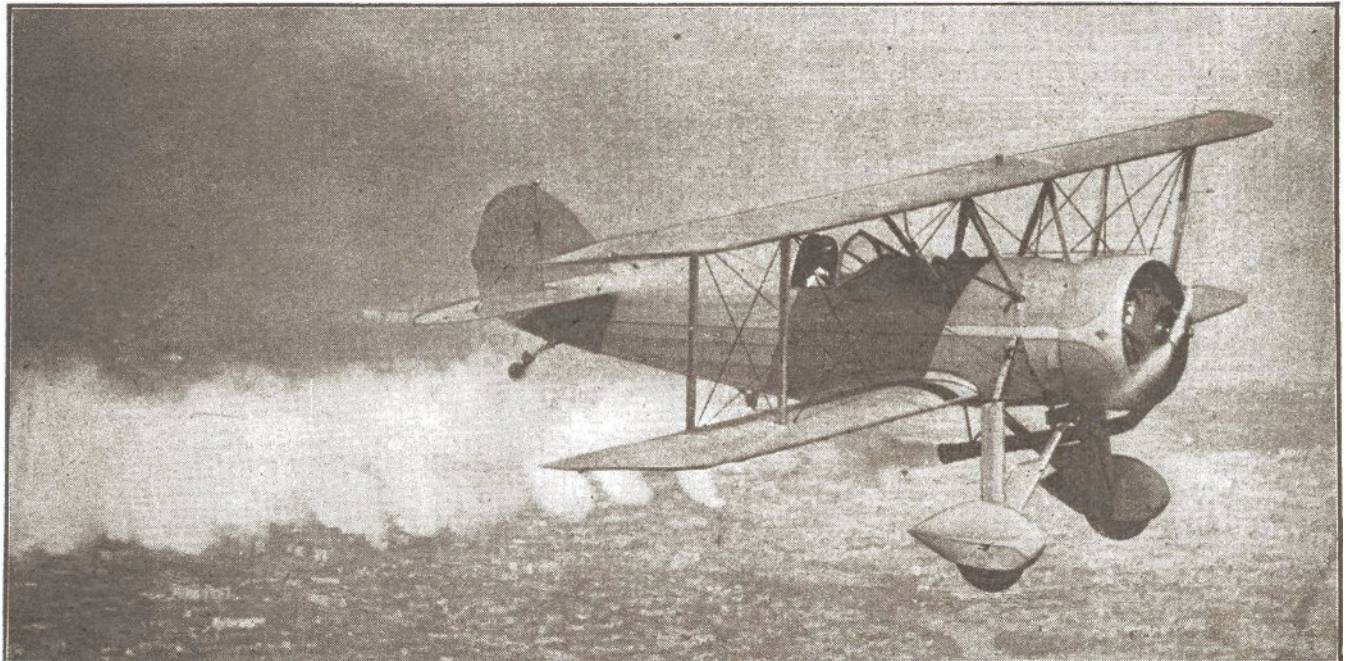

wards. There it was, as if done by a giant invisible hand, neatly lettered and equally spaced, the same message I had seen so many times before—from an earthbound mortal's viewpoint. It was a thrilling experience.

It was exactly 7 p. m. and we were now heading downhill for home. The evening sun, now almost over the edge of the horizon, blazed out in majestic glory, throwing wide rays which caught the inscription above, lighting it up like a thread of yellow lace.

The green and red markers of Bennett Field twinkled as we drew nearer, and soon the broad concrete runways spanned out like a welcoming hand. Stinis and Murphy taxied their ships to the apron and switched off.

"Well, how did you like it?" Andy asked.

"Grrreeeeaaat," I managed to chatter. I was frozen almost stiff!

SKYWRITING originated in England in 1922 when its inventor, Major John C. Savage, induced war ace Captain Cyril Turner to go up in his S.E.5 and spell out the words "Daily Mail" over the races at Epsom Downs. The British were all but thrown into confusion, and even the royal necks of the Windsor family stretched with dignity as the little ship carefully plotted the letters that were to startle a whole continent.

Also at the Downs that day was an American grain broker from Chicago by the name of Allan J. Cameron. The moment he saw the words and realized their eye arresting value, he jumped right up and made off in hasty search for Major Savage. "Look here," he said, "I think you've got something there. And when Savage agreed that was the general idea, their plans of expanding its possibilities went into action.

Cameron came back to the States and secured the American rights. The same year Captain Turner startled New Yorkers when he introduced skywriting in this country by writing "Hello U S A." One of the papers said at that time that the air above the City had been momentarily pro-

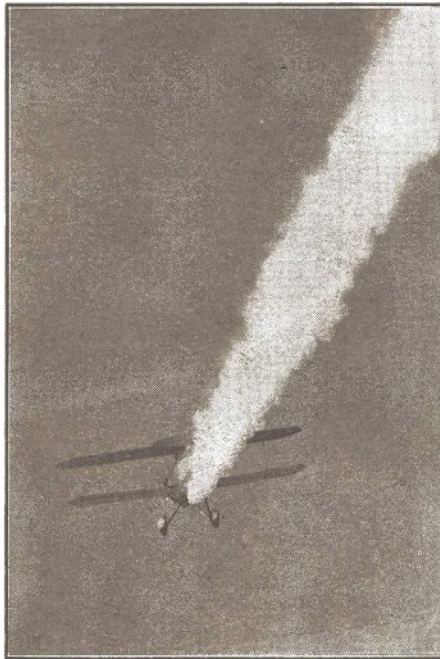

Smoke pours from the exhaust at 250,000 cubic feet per second, expands to 50-foot diameter.

fanned by the first four letters of the phrase. Apparently, something went wrong. . . . But in spite of that, the idea caught on.

The American Tobacco Company contracted for 350 writings of its famous cigarette at \$1,000 per showing. Soon, a million-dollars worth of orders were on the books and the Skywriting Corporation of America was organized. Business today isn't as good as it was back in the old days, but the dozen or so skywriting pilots throughout the country are kept busy with contracts for specific days over cities, race tracks, carnivals or beaches. If the weather is poor, it's just tough luck for the company and the pilots. When the weather is good, however, there's never a dull moment. On a national advertising campaign last season, a large advertiser had skywriting pilots visit cities and towns where skywriting had never before been witnessed. In one place, a school holiday was declared.

Who are these ace skywriters and how do they become that way? Well, there's no school where one can learn this sort of penmanship. It's self taught. Stinis had a ship and a lot of time on his hands six years ago, and had once seen a pilot do some scrawling. He decided he'd like to try it, too, and he got hold of the "smoke" and simply went out over the ocean where he could make all the mistakes he pleased without feeling embarrassed. There he proceeded to learn all the tricks of the trade.

Contrary to popular belief, loops or long dives are not used in forming any words or letters. True, these could be resorted to occasionally for quick returns after finishing a stroke, but any such stunt flying is strictly

forbidden over populated areas.

The ships used in skywriting are usually small, fast jobs—Wacos, Travelaires and Lairds are the types now in service. They are either built or rebuilt to be suitable for this type of work. Powerful engines and high lift wings are required since the ships must operate at even zero temperatures with wide open throttle. Speeds of 140 to 150 m.p.h. are necessary to keep the ships under control when maneuvering through verticals.

The smoke, before it actually becomes smoke, is a light grade of oil mixed with a certain chemical which is stowed in the wing or a forward cockpit tank. A pipe line extends from the tank to a "booster" pump and another runs to the motor's exhaust manifold. The pilot heats the motor 20 degrees more than usual, and at this temperature the oil mixing with the exhaust turns white hot. Asbestos is wrapped around the long exhaust stack to retain the heat when the ship operates in extremely cold temperatures. Once the smoke is expelled it expands to about fifty feet in diameter. In the early days, castor oil and even molasses was used. Super-heated castor oil gave good results, but the stench brought the pilots down sick. It takes about a gallon of liquid to form a capital letter, and a ship's tanks hold from thirty to fifty gallons.

Skywriting is always done into the wind and away from the sun. Upon reaching what the pilot thinks will be the best altitude, he lets out a puff of smoke to test the turbulence of the air and then he selects his spot. The wind is an important factor as it must be just right. A 50 m.p.h. wind is welcome, inasmuch as it exerts an equal amount of pressure on the letters, and as they drift across the sky they remain intact. What breaks up a message is intermittent gusts of wind or abruptly rising or falling air currents.

THE ACTUAL writing is done ^l from right to left—or backwards—using the looking-glass technique. It is done on a horizontal plane, not
(Continued on page 79)



Left: Major John C. Savage invented skywriting. First ship used was War-time S.E.5.



Right: Andy Stinis in cockpit of his craft.



Shades of the D-71 After the War, Tony Fokker organized the Atlantic Aircraft Corp.; this S-3 was one of the first jobs turned out by the factory. Both a pilot and a passenger were carried.



Here's a real prize for you collectors. Many years ago, the Air Corps used this Huff-Daland for observation work. An American-built Hiss supplied the power. Note heavy interplane bracing.

Down Memory's Runway

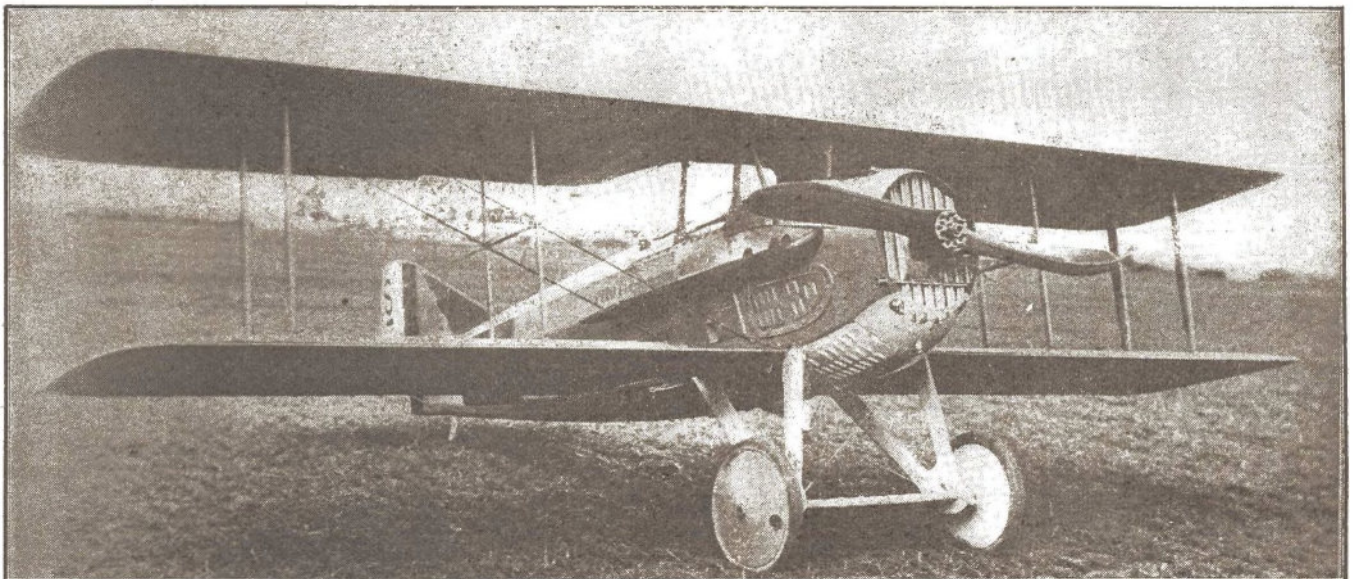

Spad lovers, here's a swell shot of your favorite job. You can very readily see why this craft was so loved by single-seat flyers of the last big scrap. Weak point of the Spad 13, according to some of the old-timers, was its sluggishness in sharp banks and turns.

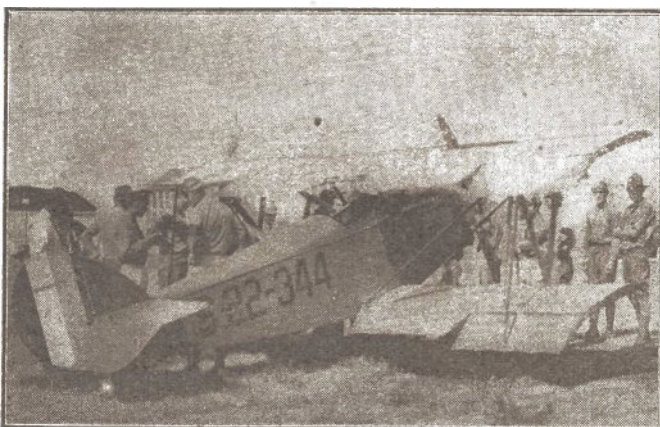

Probably the smallest plane ever ordered by the Air Corps was the Sperry Messenger 1A. It was powered by a three-cylindered air-cooled engine and was used almost exclusively in Texas. Structure was all-wood with fabric covering.

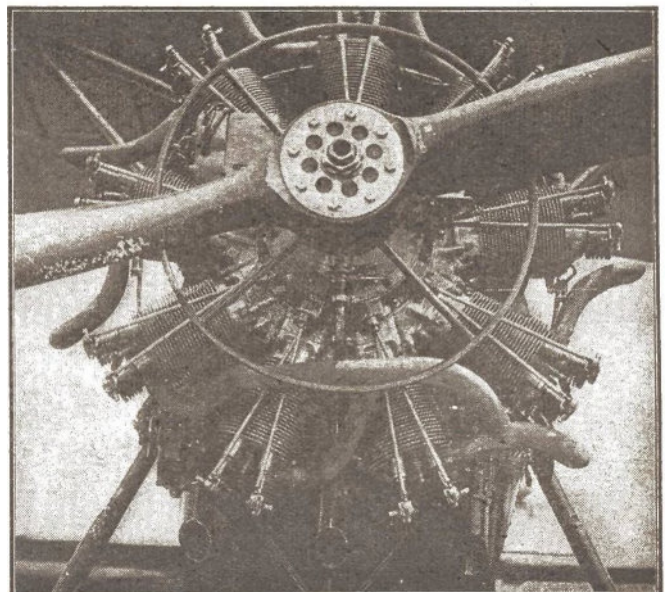

Right: The Huff-Daland TA-6 advanced trainer used an early Wright radial. That ring in front of the engine was for protection in case the propeller came loose. The ship itself was a trim looking biplane with unequal-span wings.

LURE OF THE LIBERATORS

CHAPTER I

MURDER BY SCHEDULE

IMMACULATE in dinner clothes, Eric Trent leaned back indolently in a wicker chair near the work bench of his sad-faced partner, Mortimer Crabb.

"Mort, there's a beautiful murder in tonight's paper. You're going to get a kick out of this."

Crabb looked gloomily across the basement laboratory of the old Virginia mansion they had rented. "You know they upset my stomach."

Trent chuckled. He switched on the radio, tuned in some soft music from a Washington restaurant.

"Here, maybe this will soothe your ulcers." His dark eyes went back to the murder story. Tall, debonair, Trent was a striking contrast to the ungainly figure of his inventor-partner. He had the devil-may-care expression of a professional soldier-of-fortune, where Mortimer Crabb, with his long, thin, mournful face, looked more like a caricature of an undertaker than the shrewd scientist he was. An odd team, they had spent two mad years in the European war and back in the States, with Crabb unhappily dragged into one escapade after another. At last, at his insistence, they had settled temporarily at this Virginia retreat.

Only a few miles across the Potomac from Washington, the old Mansion had belonged to a recluse who had built a high wall, topped with spikes and barbed wire, and a heavy gate with special electric control. To discourage any determined visitors from climbing the wall, Crabb had electrified the barbed-wire with enough current to shock without killing.

Trent read on for a minute, absently practicing a coin-trick, then looked up again.

"This is peculiarly interesting, Mort. Sure you don't want to hear it?"

Crabb wiped his hands on his linen duster, inserted a valve at the end of a metal hose. "All I'm interested in," he said morosely, "is getting this smoke-screen release fixed. I promised the Army I'd give them a demonstration tomorrow—and stop practicing those infernal magic tricks. You make me nervous."

Trent laughed. "Sorry, old bean, but I have to keep brushing up. If we go broke, I may have to return to the stage as a magician. But don't worry, I won't forget you. You can be my assistant and help pull rabbits out of the hat."

Crabb snorted. Trent hid a grin, lazily moved his hand. The coin appeared to vanish in thin air. He snapped his fingers, produced a light-

Already, two men had been killed by that unknown murderer—and Eric Trent and Mort Crabb were next on the death list! But to escape from that menace, Trent and Crabb took a night ride in a stolen autogyro—and shot down a fighter with Canadian markings!

by Donald E. Keyhoe

Illustrated by Ed Smalle

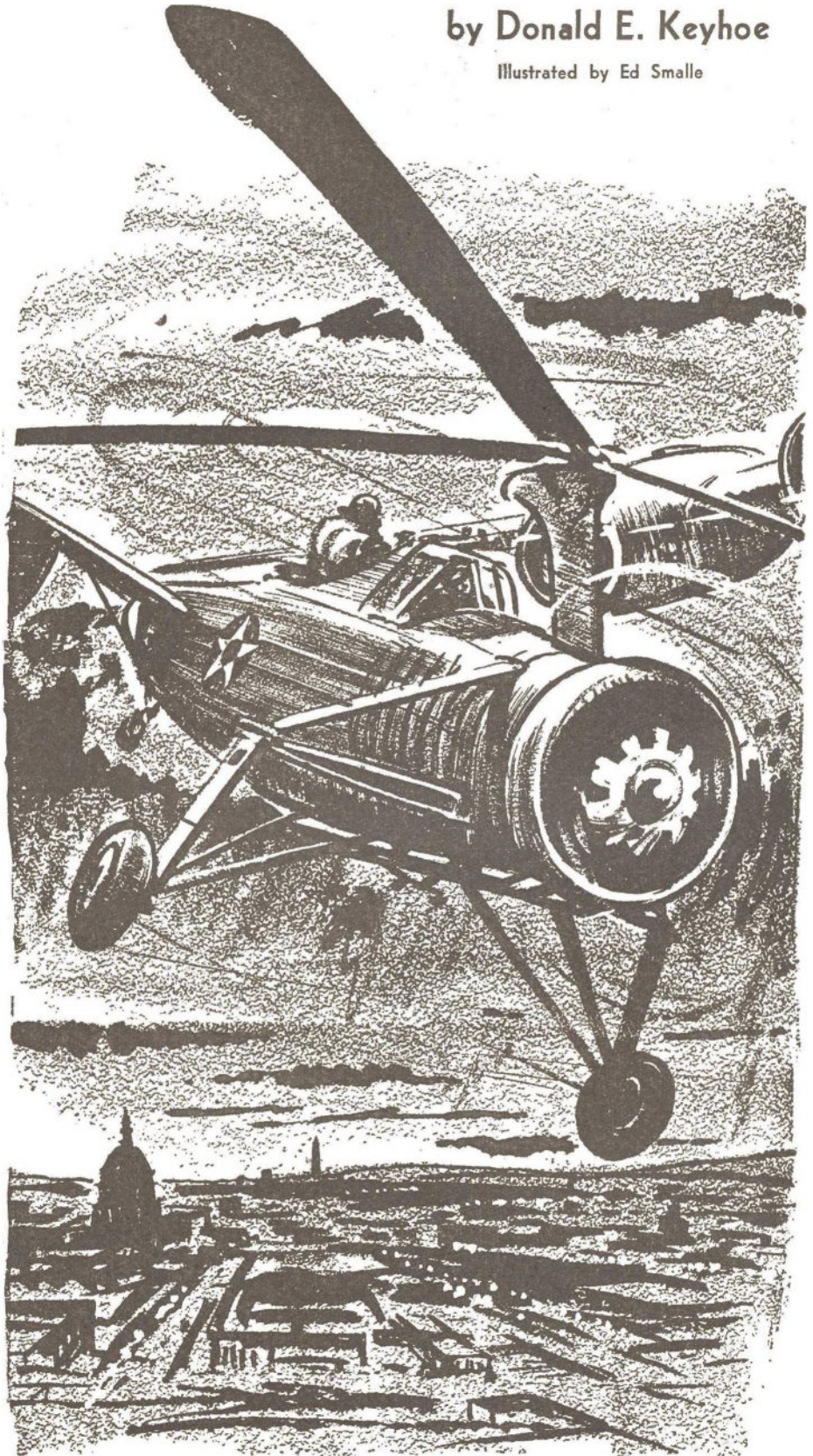

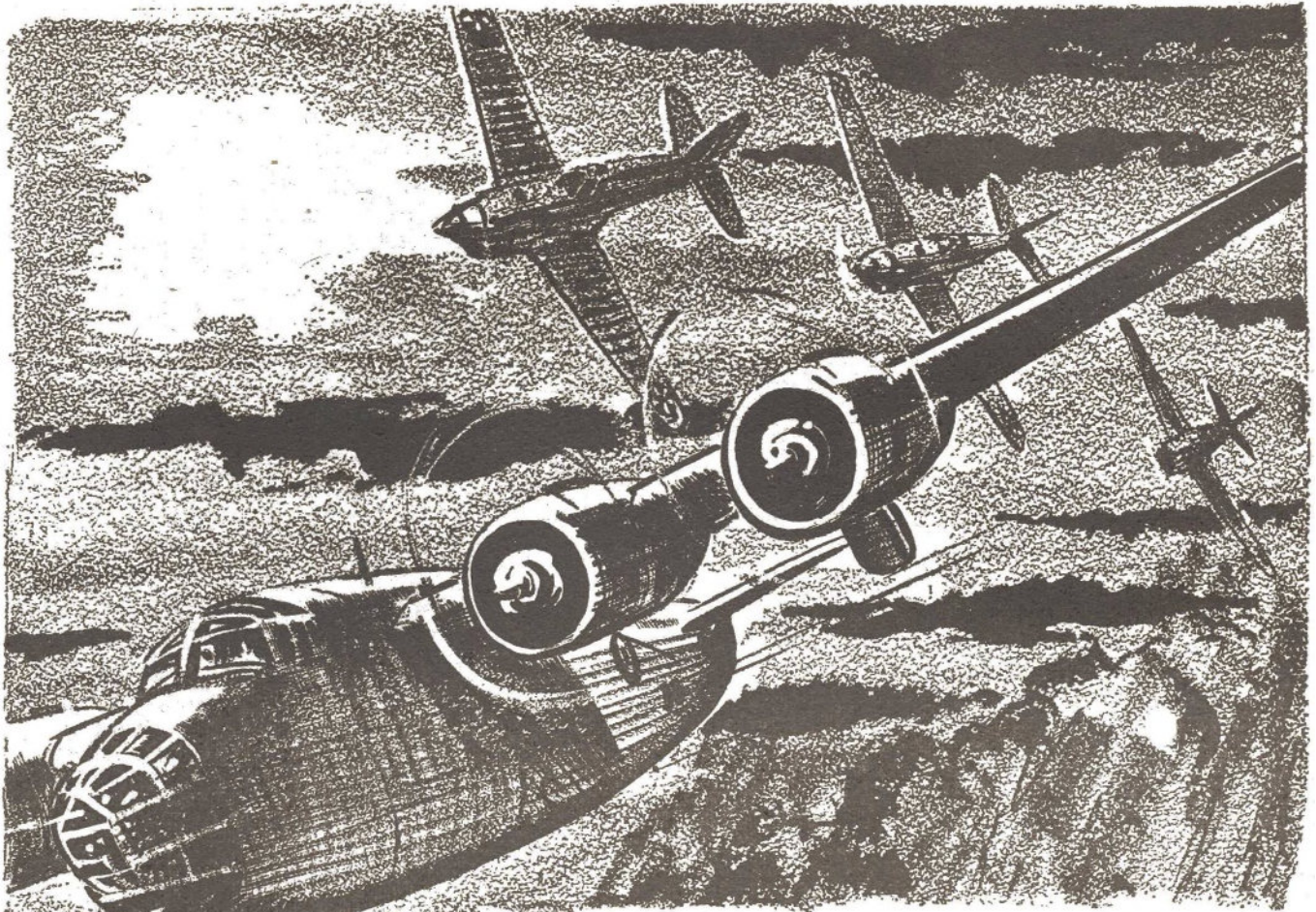

Trent brought the gyro around quickly to give Mort a clear shot with his swivel guns. And then, hurtling into the battle, came three fighters!

Cheval didn't answer his phone today. He'd gone up in his private elevator, and they found it at his floor with the doors open, so the killer didn't get out that way. There's no fire escape, and the pent-house is twenty floors above the nearest roof."

"Must have been suicide—the rat," Crabb said in a sepulchral voice.

"It's a bit difficult to shoot yourself three times in the back," Trent said whimsically.

"Well, whoever did it, it's good riddance. I'll never forget the night the Nazis caught us in that secret Belgian radio station, after Cheval tipped them off to save his hide. And Smythe grabbing at that Nazi's Bren gun to save the rest of us."

Trent's face sobered a moment. "Poor old Smythe. He saved us, and Luttre, the Belgian major—Say, I just remembered! Luttre's been a refugee here for months. I wonder if he caught up with Cheval."

"I hope he did," Crabb said grimly. He switched on a lathe, started to buff the valve-seat. Trent finished his cigarette, stood up.

"If I can't persuade you to join me for dinner over in town, I'll run along. I've already got the car out, so switch over the gate control."

CRABB SHUT off the lathe, turned to a switchboard, from which he controlled most of his working-models, including a fog-piercing

light, a dive-bomber siren and two scream-sirens for bombs, a new talking-beacon, and several other devices. Above each knife-blade switch was a neat label. Crabb threw a two-way lever labeled "Gate," closing a radio-relay circuit by which the gate could be opened by a button on the dash of the car. Trent looked at the switchboard and grinned.

"Mort, you need a special engineer—" he stopped short, as the radio music abruptly ended. An announcer's crisp voice followed:

"We interrupt to bring you a special bulletin. A second mysterious murder, paralleling the unsolved case of Rene Cheval, French refugee, has just been discovered in Philadelphia. Major Paul Luttre, refugee from Belgium, was found-dead at 5:10 this afternoon. Apparently he had been killed last night. Three bullets had been fired into his back by the unknown murderer."

As the bulletin ended, Crabb stared at Trent.

"Luttre! Why would anyone want to get rid of him?"

"I've a queer feeling it's connected with that Brussels—"

There was a crash, and splintering glass fell from a barred basement window. As Trent spun around the snout of a Tommy-gun poked between the bars.

"Raise your hands—both of you!" commanded the man behind the gun. His face was shrouded in the dark-

ed cigarette from nowhere, inhaled contentedly.

"By the way, Mort, remember Rene Cheval?"

Crabb's adam's-apple jerked up and down angrily. "That dirty traitor! As if I could ever forget—"

"Cheval," Trent said pleasantly, "is the man who was murdered."

"Cheval — murdered? How? Where?"

"New York. They found him last night, but they think he was killed the night before. He had a pent-house apartment, so it's obvious he made off with some money when he escaped from Belgium. He'd been living under an assumed name."

"Who killed him?" grated Crabb.

"No clues. The pent-house doors were locked on the inside, and the police had to break them down to get in. Somebody got alarmed when

ness, but his voice sent an electric tingling down Trent's spine. That thick, guttural note was unmistakable. It was the Nazi Gestapo agent who had killed Smythe in the raid on that secret station at Brussels!

"Stand where you are, Mr. Trent," the Nazi ordered hoarsely. "Mr. Crabb, you will unlock the basement door. And remember, I can see you if you try any trick."

Trent remained motionless where he had halted in front of the switchboard, but he flicked a side glance at Crabb.

"Do what he says, Mort. Don't try anything—he's got the drop on us."

Swearing under his breath, the inventor unbarred the door. A swarthy man with a leather jacket and helmet sprang inside, gun in hand.

"Turn your back!" he snarled.

"Not yet, *Dumkopf!*" the Nazi at the window broke in hastily. "The orders were first to make them open the safe—Crabb is working on Army inventions, and we are to take any plans we find."

The words were in German. Trent gave no sign that he understood, but from the corner of his eye he watched as the swarthy German approached, marching Crabb ahead of him. There was an instant when the man's eyes shifted toward the safe. In a lightning movement, Trent threw himself backward against the switchboard.

With a deafening screech, the dive-bomber siren went on just as the blinding rays of the fog-piercing light stabbed at the wall with the windows. Trent hurled himself to one side, lashed out at the German's right forearm. The pistol blazed as the man's finger contracted, but the bullet went into the floor. Before he could fire another shot, a mighty blow from Crabb's fist sent him thudding against the switchboard, knocking the siren switch open.

Flame jetted from the muzzle of the Tommy-gun and Trent saw the man behind it, his face taut with rage as he fired blindly toward the fog-light. A strangled cry rose above the snarl of the machine gun, and the swarthy Nazi toppled to the floor. Trent snatched up his pistol, pumped two shots at the window. There was a clanging sound and the whine of a ricochet, and then through the broken window Trent heard the thud of running feet.

"Come on!" he told Crabb, and they ran for the basement door. The rays of the fog-light were streaming out into the dark and Trent saw the Tommy-gun on the ground. The magazine was empty. The Nazi agent was running toward an autogyro which stood fifty feet inside the wall. Half-way to the ship he flung a look over his shoulder and saw Trent and Crabb. At the same moment Trent realized that the gyro's engine

was dead, was not turning over.

"Look out, Mort—the car!" he shouted. But even as he gave the warning, the German sprinted desperately toward the machine. Trent pitched a shot after him as he leaped under the wheel.

THE MOTOR roared and the car plunged down the drive. Screaming in second gear, it smashed headlong into the gate. There was a crashing of broken headlights, fenders, and bumper as the gate went down. Then the car lurched drunkenly out onto the road and turned toward Washington. Trent wheeled to his partner.

"Get that gyro's engine started! I'll be right back."

He raced to the basement, hastily searched the dead German. In one pocket was a hotel key, in another a wallet and a Washington guide-book. The other pockets yielded nothing of importance. The sputter of the gyro engine was settling into a steady drone when he reached the ship. Crabb hurriedly relinquished the pilot's seat.

"You take it! I don't know how to fly these things."

Trent snapped his safety belt. "Hang onto your hat, Mort. Here we go!"

The engine revved up and the motor suddenly whirled to top speed. With a breathtaking upward leap, the gyro jumped twenty feet in the air and then swung ahead under Trent's skillful touch.

"You crazy idiot!" grated Crabb. "You're supposed to take at least a little run with these things."

"Not this baby," said Trent. "Our friends have presented us with a 'Leaping Lena'—one of the new jump-gyros. They're made for operating off British freighters in convoys."

He had slid the cockpit enclosure shut. Now he swooped down over the road, trying to spot the fleeing Nazi.

"There are a hundred cars down there," howled Crabb. "You'll never pick him out—and what could you do, anyway?"

"Unless the Brownings they've got hidden under this cowl are made out of wood, I can do plenty. What's that sliding hatch behind you?"

Crabb twisted around. "The devils have got another gun hidden there! But we can't go blasting at him—we might hit the wrong man. Besides, that's a brand-new car!"

"Fine time to be thinking about money, when the Gestapo is on our neck," said Trent. "That blood-thirsty lad down there is the bird who killed Smythe. He and his confederate were probably the ones who

murdered Cheval and Luttre. The gyro would explain how they got at Cheval. They could have easily landed on the pent-house's terrace and jumped off again after killing him."

"But why?" demanded Crabb. "Why should the Nazis want to wipe out Luttre and Cheval?"

"And us," said Trent. "We're in on it, too. For some reason, they evidently want to get rid of everybody who was in that cellar at Brussels. We were third on their murder schedule."

Crabb shivered. "Well, thanks to you they missed connections. Hey—look out!"

Trent had nosed the gyro down steeply. They skimmed over a line of cars at the approach to the Highway Bridge. Trent pulled up as astonished motorists gaped at them, disgustingly shook his head.

"Wrong car. He gave us the slip, all right. Take over while I see if this stuff will help us any."

The inventor gingerly took the controls, climbed out of the Memorial Highway lights. The ceiling was low, with only an occasional break, and he held the ship at six-hundred feet. Trent inspected the German's wallet and hotel-key under the instrument-board light.

"Hotel Plaza-Grand, Room 817... H-m-m, plenty of folding money here, but no identifications. From this guide-book it looks as though he's been putting on a tourist act. Several places here are marked. 'Be sure to see this.'"

Trent was holding the guide-book closer to the light when Crabb gave an ejaculation. The next instant, landing-lights flared through the gloom, focussing on the gyro.

"Grab it, Eric!" Crabb yelled. "Get us out of here—I can't see!"

Trent seized the controls, banked swiftly. One of the lights angled after them, brightly flooding the ship. Trent pulled up in a full-throttle climb. He had barely hauled the stick back when four glowing streaks of tracer shot past the nose of the ship. With a crescendo screech that rose above the drone of the gyro's engine, a Curtiss P-40 hurtled down through the glare of light.

CHAPTER II

FUGITIVE FLIGHT

TRENT THREW the gyro into another hasty turn. He shook off the dazzling light-beam for a moment and the P-40 roared past. As the fighter twisted back, he had a brief glimpse of the passenger plane. It was a four-engined Consolidated bomber with the regulation running-lights.

The Consolidated banked sharply as the P-40 charged again at the gyro. One of its lights flashed across the tail of the gyro, but Trent zoomed out of the rays before they could blind him.

"Give that P-40 a burst!" he shouted back at Crabb.



"Are you crazy?" Crabb howled. "That's an Army ship!"

"Army or not, I don't like bullets!" Trent snapped the gun-circuit switch, tripped the hidden Brownings on his cowl. The fighter twisted aside, its tracers just missing the rotor. Trent heard a muffled yell above the din of engines and he saw Crabb jerk the concealed rear-cockpit gun up into firing position.

"Hold it—I'll give you a dead shot!" he ordered. The Curtiss job was curling back from the top of a swift chandelle. Trent banked hastily threw in the rotor switch. The gyro gave a wild leap, and the P-40's tracers blazed into empty space. In a furious attempt to down the gyro before he overshot, the fighter pilot ruddered into a brief skid. Trent yanked the throttle shut and the P-40 catapulted on past, its tracers lancing over the Consolidated. The big bomber nosed down, plunged across the Potomac toward Bolling Field.

The gyro had come almost to a complete stop in mid-air. Just as it started to settle, Mortimer Crabb snapped a fiery blast from the .30-.30. The P-40 gave a crazy lurch, then zoomed frantically. Searchlights from Bolling Field and the Naval Air Station were pawing at the sky, and Trent saw the fighter's insignia just before it disappeared in the lowering clouds.

It was a Royal Canadian Air Force plane!

He opened the throttle, climbed the gyro after the fighter. There was a small break in the clouds, but when he climbed through it was too dark to see anything. He cruised away from the glowing spots where searchlights probed at the overcast, then let down a few miles West of the Potomac.

"Drop that gun back out of sight," he directed Crabb. "We're going to pay a little visit to Bolling, and I don't want them to get off on the wrong foot."

"I never knew it to fail," Crabb said dismally. "Just when everything's nice and calm, you drag me into some mess and I nearly get killed."

Trent looked back in mock indignation.

"I suppose I hired those Nazis to start the ball rolling. A lot of gratitude I get, saving your neck."

"Why the devil did that Army pilot jump us, anyway?" grated Crabb.

"He wasn't an Army pilot—not our army, at least. That was a Canadian job. I'm wondering about that Boeing pilot, too. Maybe it was just to keep clear of us that he spotted us with his lights, but that P-40 pilot certainly had a good target."

"I was a fool to get into this ship," Crabb said sourly. "If I had any brains I'd never get within a thousand miles of you."

"Think of the excitement you'd miss," grinned Trent. He headed the gyro across the river, letting it settle slowly as they approached Bolling Field. The floodlights were on, and he saw the Consolidated in front of a hangar, with a crowd of men around it. Several cars were parked nearby. The gyro was four hundred feet from the ground when some one saw it. A guard detail came running

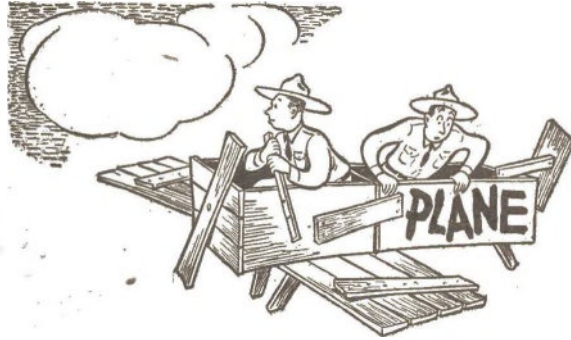

"This is carrying 'things a little too far!'"

as Trent landed, and four rifles instantly covered them.

"Well, well, the reception committee," said Trent. He cut the engine, climbed out.

"That's the plane that attacked us!" a voice said fiercely, and a big, raw-boned RCAF squadron-leader pushed his way through the crowd of Air Corps officers and mechanics. Back in the glare of the floodlights Trent saw thirty or forty other men in RCAF uniform.

"You're under arrest—both of you!" barked an Air Corps major who had followed the squadron-leader. He turned to a pompous, middle-aged man in civilian clothes. "It's all right, General. We've nabbed them."

"Now that you've all spoken your little pieces," Trent said amiably, "suppose you listen to mine."

"Eric Trent!" sputtered the general. "What the—have you lost your—"

"Now, now, General, think of your high blood pressure. Mort, you remember General Busby, assistant chief of G-2. We gave him some slight help in the Red Devil affair."

Crabb nodded gloomily, and the

Canadian squadron-leader looked blankly at the general.

"But they fired on us, sir! It was obviously a plot to block our plans."

"There must be some mistake, Woring," muttered Busby. "These two men have helped the Government several times on special jobs. As a matter of fact, Mr. Crabb is right now working on a device for the Army."

He turned to the Air Corps major. "Get that crowd back, Major Kendall. I want to talk with these men privately."

KENDALL ordered the guard detail to release Trent and Crabb, and in a few moments only General Busby and Woring remained with them.

"Now, Trent," Busby said huffily, "suppose you explain—"

"I still think you're making a grave mistake, General," Woring broke in. His cold blue eyes rested on Trent. "I've heard this man's name before. He was mixed up in some affair in France—"

"He's always mixed up in some crazy business," growled Busby. "But he's no traitor, or he wouldn't have exposed that Nazi Red Devil scheme."

"Thanks for the kind words, General," chuckled Trent. "Here's what happened." He described the murder-attempt at the mansion and what had followed. Woring had a stare of plain disbelief and even Busby looked dubious when he finished.

"Don't take my word for it," said Trent. "You can find the German's body in the basement. By the way, what about that P-40?" he added, turning to the squadron-leader.

"Just what I was about to ask you," Woring said caustically. "The pilot appeared to be working with you."

"Are you blind?" snorted Mortimer Crabb. "He was doing his best to kill us."

"All I know, you both fired on us," Woring retorted.

"Stop this wrangling," snapped Busby. "Trent's story is a little fantastic at first thought, but after remembering other things done by the Purple Legion it's not so hard to believe."

"Purple Legion, eh?" said Trent. "Apparently I haven't been keeping up with my reading."

Busby hesitated, with a quick glance at Woring. The squadron-leader shrugged.

"We've kept it quiet," the general said, "but since you've been dragged into this you may as well know about it. England's bought twenty-six Consolidated B-24 bombers—they're calling the ship the Liberator."

(Continued on page 58)

Modern Planes Album

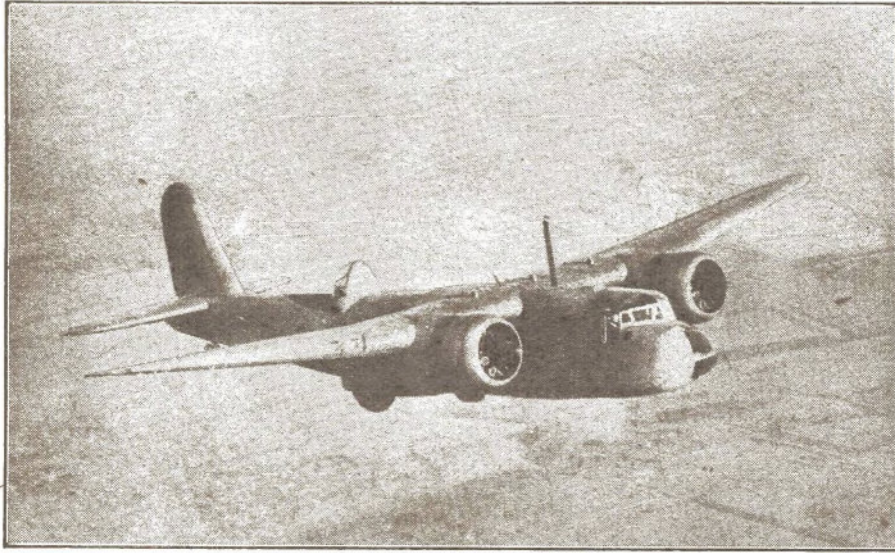

BLACKBURN BOTHA

BLACKBURN BOTHA
THE BRITISH are still turning out several fine machines, and it is now said that their monthly production is practically equal to that of Germany. It is now well known that they have at least seven new hush-hush or secret types which include the Tornado, the Spitfire III, and the Airspeed Whirlwind, a new and very

unorthodox plane which may already have seen service as a night-fighter. Their latest "for publication" type is the Blackburn Botha bomber shown in FLYING ACES this month for the first time.

The Botha, obviously named in honor of the famous South African general, is a two-engined long-range bomber of none too pleasing design.

The Blackburn firm, however, does not go in for pictorial effect, as will be noted by a glance at their very efficient Roc and Skua dive-bombers.

From official British sources we learn that the Botha was originally designed for Coastal Command work to augment the Lockheed Hudsons which have so long borne the brunt of off-shore work. It was intended as a general reconnaissance and torpedo-bomber, and is powered with two 900-h.p. sleeve-valve Bristol Perseus engines. It has a span of 59 feet, a length of 50 feet 11½ inches, and a height of 18 feet. The rear turret retracts and leaves nothing much more than a bulge when in the down position. The turret is of a new type and is of much speedier action than those we have seen in the past. The wheels retract into the motor nacelles but do not seem to fold all the way up.

The wing is built-up of three sections. The main panel carries the engine nacelles; the outer panels taper considerably toward the tips. The ailerons are balanced and the flaps are hydraulically operated. The rudder and elevator are built on metal frames and are covered with fabric. No performance specifications have been made available.

DOUGLAS 8A-20A
SHIPS ARE being turned out at top speed now that the Defense Program is getting under full swing and the much-debated Bill H.R. 1776 has been passed by Congress. And one of the machines being fabricated in mass production is this new Douglas 8A-20A attack-bomber.

The craft itself is similar to the Boston which is being used quite extensively by the British. It seems to be cleaned up slightly, however, but there is nothing definite about this. It might merely be an illusion caused by the angle from which our photograph was taken and because the ship is not wearing camouflage.

No data is available concerning the engines used on the 8A-20A, but they appear to be Pratt & Whitney plants. The Boston used 1,050-h.p. P&W's, and it's quite possible that the Air Corps job uses the same.

The fuselage is of monocoque construction, with Alclad skin laying over transverse frames and longitudinal channel-type stringers. The bomb bay is located directly amidships, between the pilot and rear top gunner. Doors swing down and out when in position for bombing.

The wing is built-up in three main

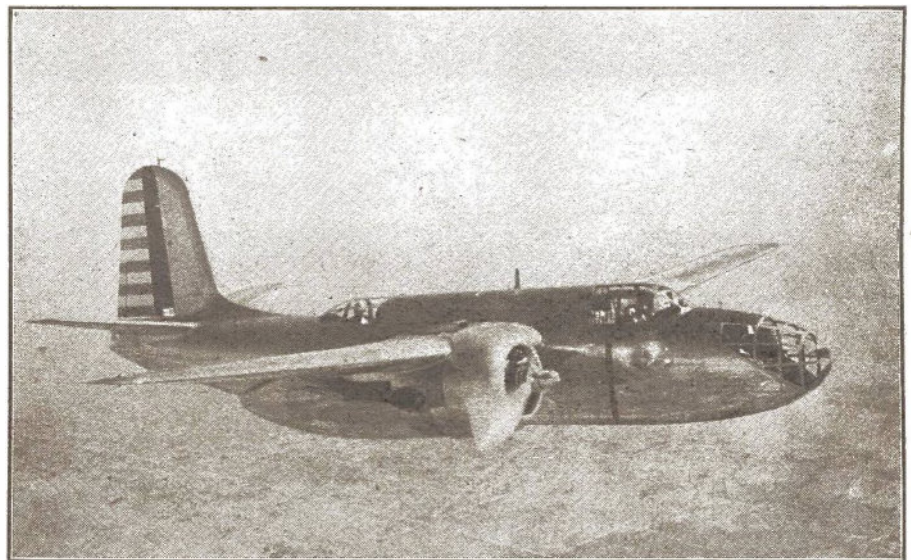

DOUGLAS 8A-20A

sections with the center panel integral with the fuselage. Outer panels are attached at a point just outboard from the engine nacelles. Wing tips are detachable. Like the fuselage, the wing is covered completely with metal alloy sheet.

The engine nacelles are oversized and taper smoothly to a streamlined section. The main landing wheels re-

tract into these wells, with special flaps folding up to complete the smooth surface of the nacelle. The front wheel folds up and back into the fuselage nose; it also is housed in by swinging doors.

One gun is fixed to fire forward, being controlled by the pilot. This weapon is on the left side and is charged by the bomb-aimer up front.

CURTISS TOMAHAWK

CURTISS HAWK 81-A's—Tomahawks, as the British call them—are beginning to arrive in England in fairly respectable numbers, according to reports. Reliable sources have it that the Curtiss Company is turning out 50 of these ships per week—half for Uncle Sam and half for the Royal Air Force.

The Tomahawk is powered with the liquid-cooled Allison, rated at 1,090 h.p. at 15,000 feet. Its speed has not been made public by either the Air Ministry or the Curtiss Company, but from all reports the machine is an excellent performer. It takes off in 13 seconds and the wheels are tucked away in 35 seconds.

A short time ago, according to reports, one of these Tomahawk jobs was sent aloft by the English to engage in a mock battle with a captured German Messerschmitt. Both ships carried camera guns, and when the film was developed it proved that the American ship was the better of the two on maneuverability. The Messerschmitt, however, is more speedy.

All of this, of course, is very enlightening, for we in this country very rarely know what our military ships can do. In this case, we had to find out from the British.

Six guns are mounted in this export version of the P-40—two in each wing and two firing through the prop arc. While this gives much more fire-

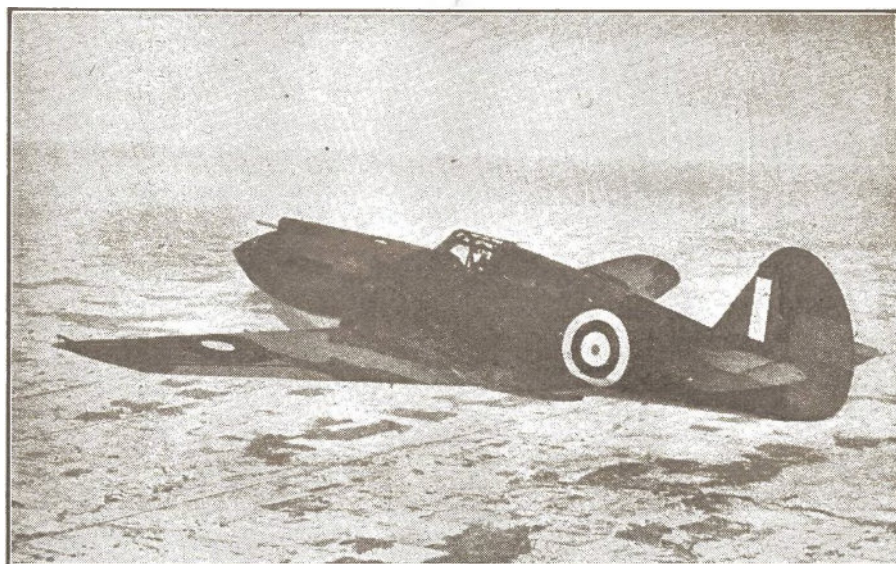

CURTISS TOMAHAWK

power than the Air Corps' job, which has mountings for only four guns, it still is far inferior to British fighters. The Hurricane, for instance, with eight weapons, has a concentrated fire-power of 9,600 rounds per minute, whereas the Tomahawk can throw only 4,800 rounds per minute and the P-40 has a rate of fire of 3,400 rounds per minute. Browning .30 caliber guns, which are mounted in all three ships mentioned, have a firing rate of 1,200 rounds per minute, but synchronizing the weapon cuts down the rate of fire to 500

rounds per minute.

The fuselage is built-up of the usual bulkheads and stringers with metal sheet covering riveted in place. The wing, likewise, is of all-metal construction with sheet covering. Ailerons are fabric covered, as are other control surfaces, and the flaps are faced with metal sheet.

Other data: Span, 37 feet 4 inches; length, 31 feet 8 inches; height, 10 feet 7 inches; empty weight, 5,475 pounds; loaded weight, 6,978 pounds; wing area, 236 square feet; normal range, 873 miles.

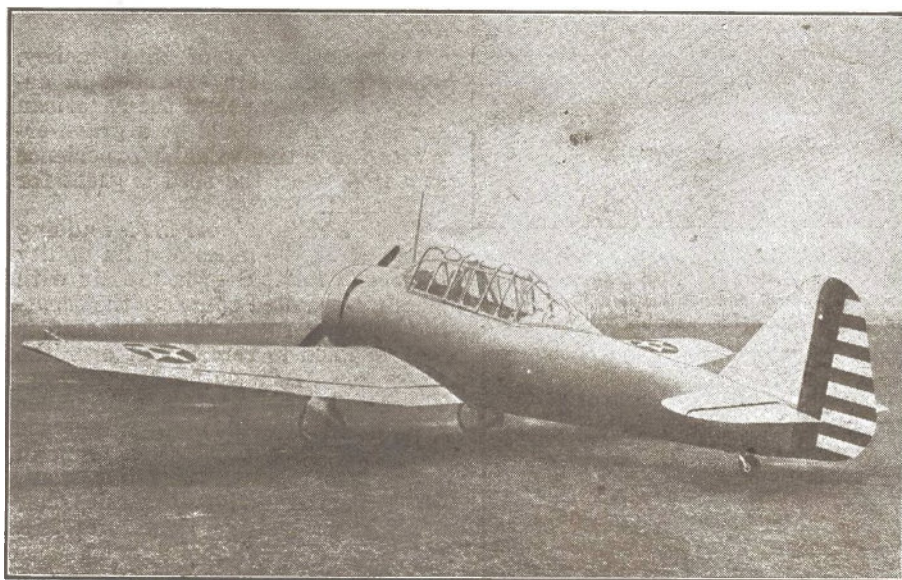

FLEETWINGS XBT-12

FLEETWINGS XBT-12 INSTRUCTION CRAFT are being designed now with almost the same rapidity that fighters and pursuits came out up until three years ago when Uncle Sam realized what FLYING ACES had been telling him for so many years—that the American Air Force is not strong enough. And the newest of these machines is

the Fleetwings XBT-12 experimental basic trainer.

This ship is of almost 100 percent stainless steel construction. It has a double spar wing center section and a single spar outer wing panel which is detachable just outward from the landing gear. The machine is extremely sturdy in construction and affords exceptionally good visibility

to facilitate student instruction.

The cockpits for student and instructor are covered in much the same manner as found aboard first-line single-seat fighters. The only difference seems to be that the XBT-12's canopy is higher. This, of course, is to make for better visibility. A complete set of instruments is in the front cockpit, while the rear pit has only primary flight controls, throttle mixture, and flap and propeller controls.

This Fleetwings is constructed in the usual manner, utilizing bulkheads and stringers with sheet covering. Instead of being riveted in place, however, the skin is spot-welded. The crash protector is located between the two pits and is of the tripod type. The wing framework is covered with corrugated sheet before attaching the outer skin.

Other data: Span, 40 feet; length, 29 feet 2 inches; height, 9 feet 2 inches. Additional information is withheld by the War Department since this ship is still in the experimental stage and is therefore secret. It's an even bet, however, that many of them will soon be ordered to train the thousands of fledgling pilots for our future Air Force.

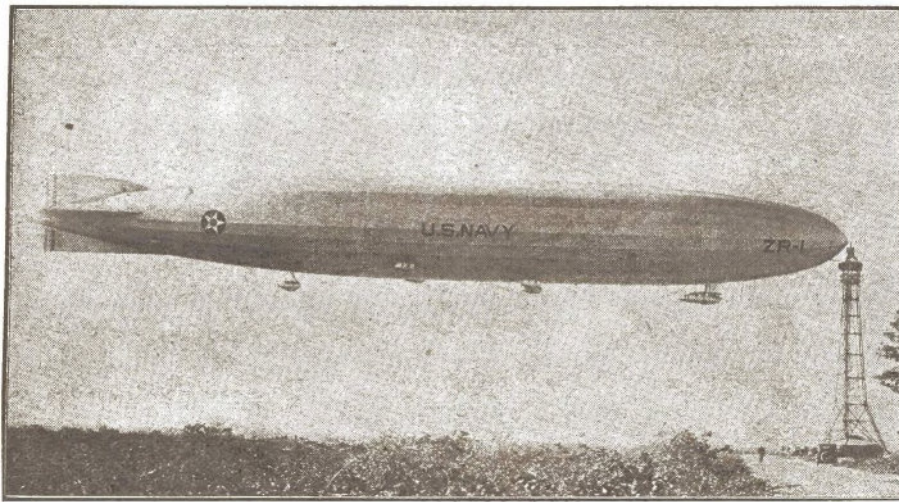

Official opinion has been so strongly against dirigibles since the "Von Hindenburg" disaster that none have been built for our armed services since then. For protecting our coasts, however, these ships are without a peer.

The Shenandoah crashed during a line squall. Mishaps of that sort could now be avoided.

WE NEED AERIAL AIRCRAFT

BY WILLIAM HERBERT RANDALL

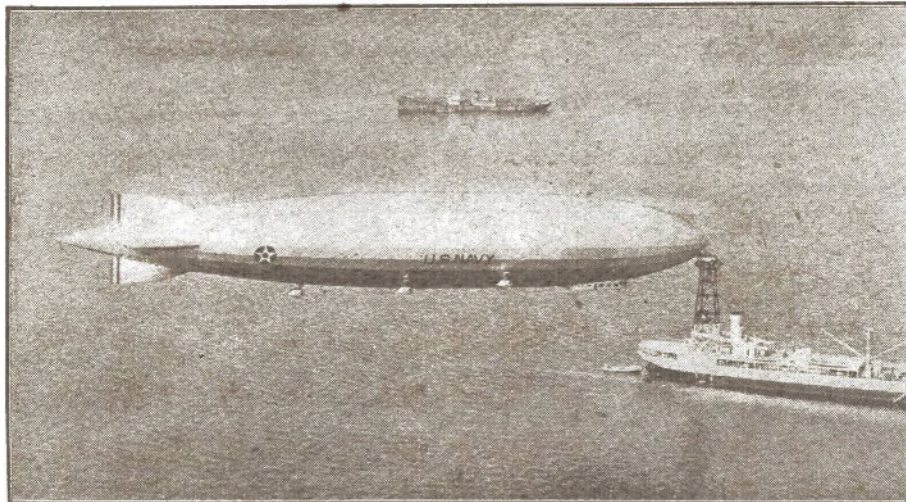

Above: Our only remaining dirigible moored to the "Patoka." The "Los Angeles" made a total of 250 flights, covering 140,000 miles, before she was decommissioned. Below: Swarms of small fighters, like this Curtiss F9C-2, could be dispatched from aerial aircraft carriers. They would be invaluable for scouting our coasts, being on the lookout for possible enemy fleets.

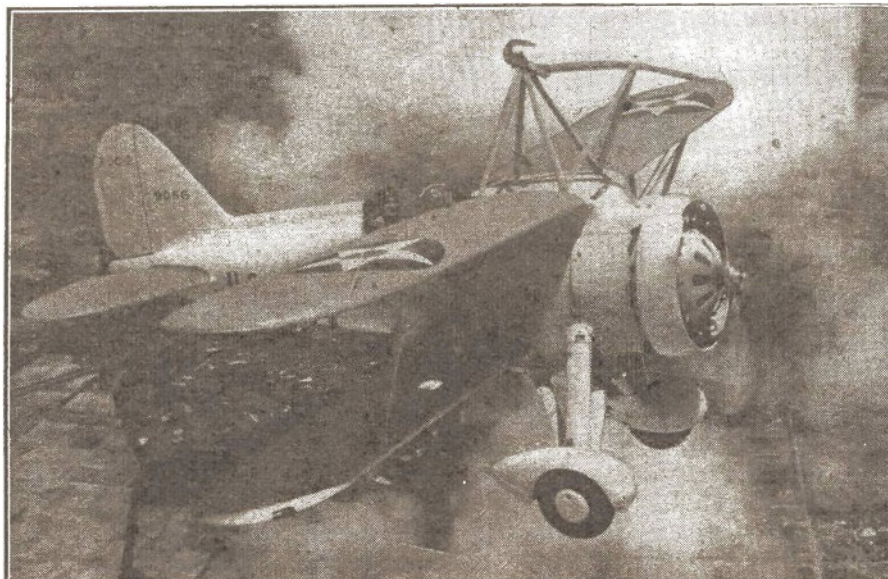

UNLESS REAL activity soon develops in the lighter-than-air field, dirigibles are very likely to become a thing of the past for America's Air Force within the next few years.

The officers and men will either pass into retirement or turn to other fields of endeavor, and America will find herself faced with a lack of trained personnel with which to man the airships she will most certainly need.

A great amount of time, money, and lives has been expended in developing this branch of the American Air Service. It would be a grave error to waste this valuable experience at a time when the need is great for such craft.

The airship's normal cruising range of 10,000 miles and its ability to remain motionless in the air with all engines halted enhances the scouting value of such craft. The ship is thus enabled to remain out over the water for weeks without refuelling. The airship sea anchor, now under research, will even further increase the time now possible to remain away from base. Unlike our giant bombers, the dirigible carries her protective convoy of fighters at rest within her tremendous hulk, conserving also of their fuel until needed for defense and scouting.

When it finally does become necessary for the airship to refuel, it is possible for her to land for this purpose on one of our surface aircraft carriers at sea. This was found feasible in 1929 when the dirigible *Los Angeles* contacted the carrier *Saratoga* at sea, landed, exchanged personnel, and took on supplies and fuel. Further, contact can be made with the specially-constructed mooring ship *Patoka*. The *Patoka* has long been proven an ideal ocean anchor

America's last dirigible was the "Macon." She was destroyed during a storm, but new weather-forecast methods would prevent re-occurrence of such tremendous disasters.

and refueling depot for American dirigibles.

Our frontiers have been advanced considerably by acquisition of the eight new naval and air bases from England, and we seem self-elected to become the defender of the Western Hemisphere. Watching over a coast line so tremendous will be expensive.

Ten dirigibles can be built for the price of *one* surface carrier, and each dirigible would be capable of mothering fifteen fighter planes. This provides a group total of 150 fighters with ten separate bases. At this time we have no surface carrier that can handle anywhere near this brood of fighting aircraft.

No matter how many planes a car-

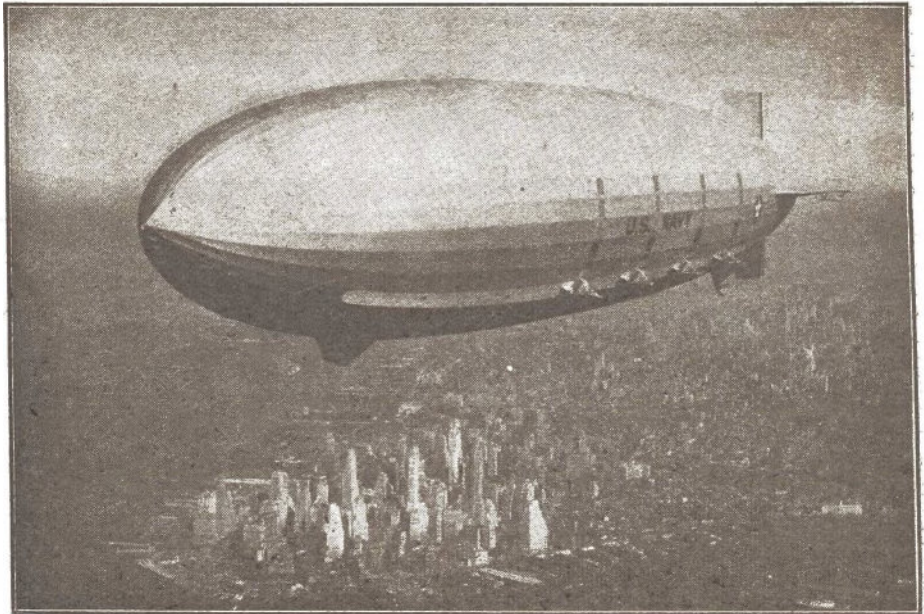

CARRIERS!

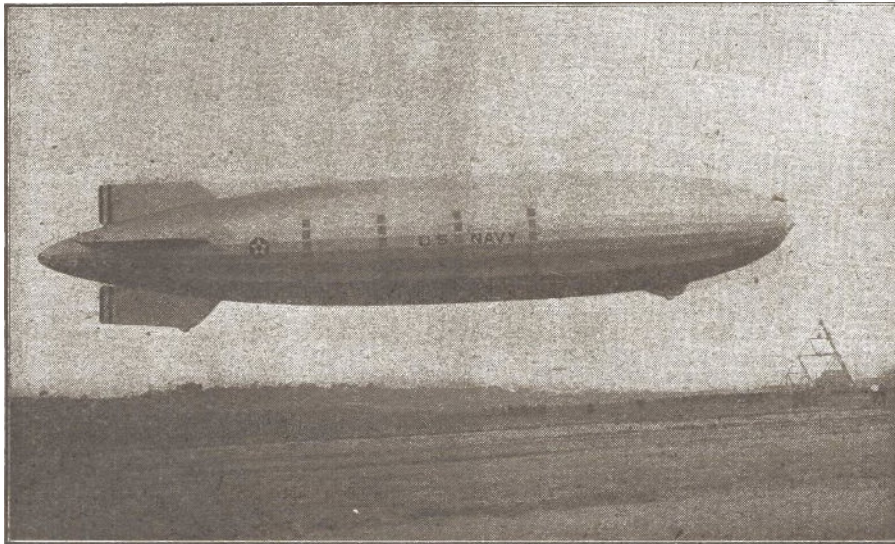

Sister ship of the "Macon," the "Akron" was also equipped to accommodate fighter planes in a special hangar. Our author argues that these craft would offer ample protection.

rier may be able to accommodate, those planes can scout only two-fifths of their cruising range away from their base; two-fifths must be reserved for returning and the remaining fifth as a reserve in case contact is not made at once. Ten groups divided into as many separate units can therefore cover ten times the area now possible with a single surface carrier, and in case of threat these ten units can flee in as many different directions at almost triple the fastest surface carrier speed.

THIRTY DIRIGIBLES would cost no more than *three surface aircraft carriers*. Place one dirigible every 200 miles along our coasts, five hundred miles at sea, in the Atlantic, Pacific, and the Caribbean. Each

would hover motionless at the center of its sector while her brood of fighting ships took on fuel and dropped out to scout a two hundred mile radius. A cordon of watchful eyes would thus be formed that no enemy could possibly penetrate without discovery.

If an enemy fleet is sighted by one of these planes, the information would be radioed back to the mother ship for relay to the defensive air and surface fleets. The planes would then rally round to escort the mother ship to safety before entering the battle themselves.

Within five years America should be equipped with a none-better two-ocean Navy with all the trimmings. Why not base these fleets strategically and place long-range bombers at Caribbean, Atlantic, Pacific, Canal, and South American bases, scouting our extended coasts with dirigible-mothered aircraft. The scouts could put this mighty surface force into

action at any threatened point, conserving the tremendous and costly energy of the Navy until actually needed for defense.

The Navy admits that its present force of six surface aircraft carriers is incapable of forming a scouting line on all our coasts simultaneously. But the Navy must also admit that thirty dirigibles, representing only *half* the cost of the present entire surface carrier force, *could* do the job thoroughly.

Airplane operations from dirigibles are far simpler than those carried out aboard surface carriers. Within the hangar space of the dirigible is a trapeze acting on the principle of a traveling crane. A launching bar fits into a slip-hook on the upper wing of the plane to be launched. A sliding trap opens and the ship is lowered through the opening. The machine's engine is then started and the pilot himself releases the hook, simply dropping away to gain flying speed.

In returning to the mother ship, the plane flies up beneath the dirigible, the flyer jockeying his craft until the hook on the upper wing engages the trapeze. He then shuts off his power plant and is drawn up into the cavernous depths of the mother ship, the trap is closed and the ship rolled away for servicing.

Aboard surface carriers, planes must *lift* themselves from the deck of their mother ship, making load a distinct hazard. Planes dropping out of airships find weight advantageous as it aids in gaining flying speed. War craft operating from dirigibles can therefore carry almost double the load of fuel and bombs possible for craft taking off from surface carriers.

The most common argument against the further construction of dirigibles is that they are of no "practical use"; that their worthlessness was evidenced in the World War.

Others claim a single incendiary bullet will send the dirigible down in flames; that concentrated fire from

the enemy will rip the gas bags to shreds, allowing the precious lifting force to escape.

Lighter-than-air advocates will concede only one argument as sound. This is the obvious fact that a dirigible affords an excellent target for today's highly efficient anti-aircraft guns. The point is conceded because there is no reason for the dirigible to come within range of such guns. The main purpose of the American Naval dirigible would be to scout and act as an aircraft carrier. An airship never engages in actual warfare or bombing. That is not her mission any more than it is the mission of surface aircraft carriers. They remain at a safe distance while their planes go forth to fight, maintaining themselves as a base of operation for their planes.

This is not what has retarded American airship progress. Public opinion, based upon the unfortunate crash record of the past years, has been the airship's greatest enemy.

The fate of the *Shenandoah*, *Akron*, *Macon*, and *Von Hindenburg* are too fresh in the public mind. Line squalls were responsible for the last two American disasters, but dirigibles can move three times as fast as these storms and we have learned to avoid such atmospheric disturbances. With our present highly efficient weather observation system, repetitions of these weather crashes are not likely to occur. The explosion, on May 6, 1937, that destroyed the *Von Hindenburg* at the conclusion of her 35th Atlantic crossing could never happen aboard a helium-supported aircraft.

The public and uninformed legislators do not seem to realize that these crashes have taught us numerous invaluable lessons. Many improvements born of crash experience are begging for a chance to be tested in actual use.

DIRIGIBLE ADVOCATES can answer every argument deterrent to their profession with logic, truth, and records. It is history that Jellicoe admitted the saving of the German Fleet at Jutland by Zeppelins and conceded them to be a highly valuable adjunct to the German Navy.

It is only necessary to refer to records in the Navy Department to prove that an almost impossible number of machine gun bullets would be required to cause any noticeable damage to the gas bags of the modern dirigible. Cells have often been accidentally torn and slashed with such low loss of gas that the damage has gone undiscovered for hours. War-time Zeppelins returned to their bases many times, their cells in shreds, with very little loss of gas. Pressure is relatively low even at the top of the bag, while at the bottom it is practically non-existent.

The use of helium in preference to hydrogen as a lifting factor is probably the greatest single improvement

Self-Seal Gas Tanks

by John F. Hicks

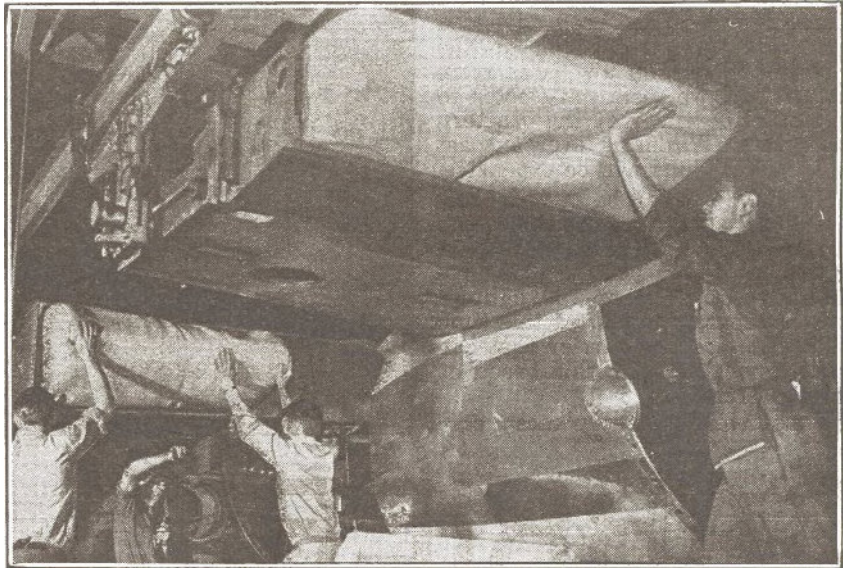

INVENTED in America and put into practical use as early as 1917, self-sealing fuel tanks are today a part of the standard equipment of America's fleet of military craft. And aside from technical details which are still military secrets, the operation of the self-sealing fuel tanks is simple.

When a fuel tank is punctured by a bullet the gasoline is brought into contact with a rubber compound which immediately swells and fills the hole, sealing it completely, preventing fires and saving fuel.

This rubber substance lines the gasoline tanks of the airplane like an inner tube in an automobile tire. Its inner surface which comes into contact with the gasoline in normal flying conditions, is inert and unaffected by the fuel. Only

when this coating is punctured by a bullet is the gasoline permitted to act upon the sealing elements of the tank.

Before a modern type self-sealing gasoline tank is approved by the Army, it must stand up to severe tests. These include vibration tests to see whether the sealing element will shake loose or fall apart under severe stress and strain. Army officers, further, tested the sealing speed of the device with stop watches to find out how quickly the lining became saturated and would seal the tank.

More spectacular are the gunfire trials where the Army inspectors fire point-blank into the tank, first with small caliber bullets and then with increasingly larger ones. Each bullet hole is photographed and results noted.

in lighter-than-air craft to date. This colorless, odorless, inert gas is more than non-inflammable for it actually extinguishes fire and is second only to hydrogen in lifting qualities.

If the gas cells of the transoceanic *Von Hindenburg* had been inflated with helium rather than highly inflammable hydrogen, that disaster would probably never have occurred. However, the world's chief sources of helium is in the natural gas fields of Texas and Kansas and its export is highly restricted. Germany, you recall, was unsuccessful in her attempts to obtain helium from America just prior to the outbreak of the present European hostilities.

Every part of an airship is accessible for repairs while in flight and even during attack. Protected by machine guns, supported by helium, and escorted by her own brood of fighting planes, a dirigible would be a

formidable fortress to conquer—much more so than a surface carrier.

Congress in 1939 authorized the construction of an experimental dirigible to embody all the new designs, but to date no action seems to have been taken despite favorable recommendations from Congress and the Navy General Board.

Rear Admiral J. H. Towers, in his 1940 fiscal report to the Secretary of the Navy, shows that in 1938 and 1940 no allotment was made for rigid airships. In 1939, \$500,000 was allowed for the construction of a rigid airship. This amount is relatively small in view of the fact that during those three consecutive years Naval aviation allotments have steadily increased—48 million, 51 million, and in 1940 the sum more than doubled to 111 million. That totals 210 million dollars, of which only one-half million

(Continued on page 74)

THREE CUBAN NAVY flyers and their Wright Whirlwind-powered DGA-15W "Teniente Menendez" returned to their Havana base on March 1st after completing a remarkable 20,000-mile "Good-Will" tour during which they visited 22 republics in North, Central, and South America.

Despite all the problems and obstacles attendant upon such a flight—including a 560-mile jump across the Caribbean Sea, numerous flights over the lofty Andes, and a visit 13,000-odd feet up in the Andes to La Paz Airport—the voyagers have completed their mission and returned to Havana without a single mishap to report.

The three ambassadors of good-will were Commander Oscar Rivery, associate director of the Cuban National Observatory, who as navigator proved he is as much at home over the Andes as at Havana's Camp Columbia; Lieutenant Juan Rios Montenegro, of whose performance as a pilot the flight speaks for itself; and Sergeant Frank Medina, whose understanding of the Howard and its trusty 7-cylinder Wright Whirlwind 760E engine of 320 h.p. is simply expressed in the report: "No mechanical difficulty of any kind encountered on flight."

DEARING LETTERS from Colonel Fulgencio Batista, President of Cuba, to the Presidents of all the American republics, the trio took-off from Havana on October 12th, the 448th anniversary of Columbus' first landfall—now believed to be San Salvador, only 400 miles eastward. They spanned Cuba to Santiago, sped across the 50-mile Windward Passage on their first water hop, and landed at Port-au-Prince, capital of Haiti.

The flyers stopped the following day to meet officials of the Dominican Republic, then continued on, crossing Mona Passage for their second flight over water, and passed over Puerto Rico to San Juan. Then came a 560-mile jump across the Caribbean Sea and a welcome by the Republic of Venezuela on October 15th. Heading southeastward along the very coast discovered by Columbus in 1492, and skirting the Eastern Andes, they next visited Dutch Guiana, stopping at Paramaribo on October 18th.

In succession, they visited the capitals and major cities of Brazil, Paraguay, Uruguay, and Argentina. Then they crossed the Andes, skirted Mt. Aconcagua (23,000 feet), which is the highest peak in the Americas, and continued to land at cities in Chile.

Carrying 180 gallons of gasoline and approximately 150 pounds of luggage, they flew on to visit La Paz, Bolivia, landing at that city's airport on December 3rd. The La Paz airport is located more than 13,000 feet up in the Andes and is the highest airport in the world. They continued on, visiting Peru, Ecuador, Colombia, Panama, Costa Rica, Nicaragua,

(Continued on page 68)



Here are the Cuban flyers who participated in the 20,000-mile journey. They are, from left to right: Lieutenant Juan Rios Montenegro, pilot; Commander Oscar Rivery, navigator and co-pilot; and Sergeant Frank Medina, mechanic. This photograph was taken at the U. S. Coast Guard base at Floyd Bennett Field before the last leg of their long tour covering the Americas.

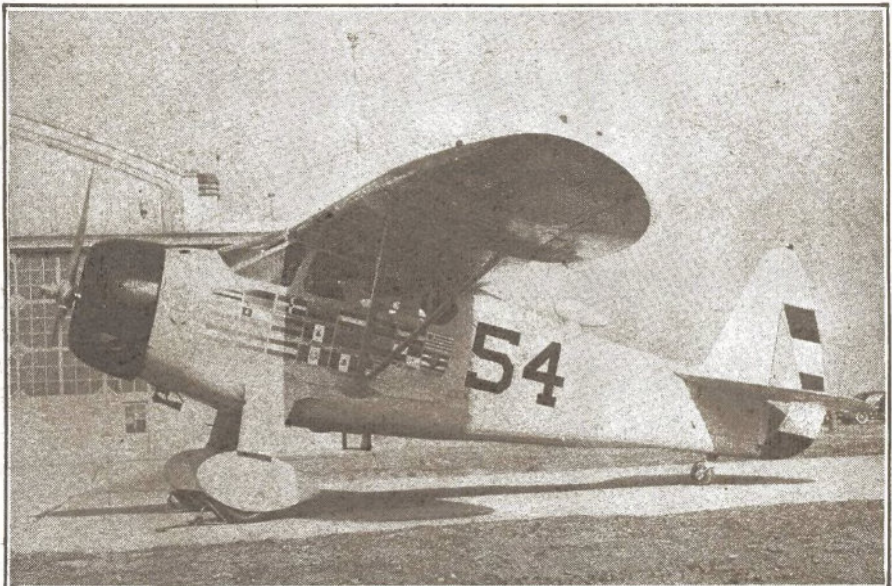

"Teniente Menendez" was the name of the Howard DGA-15W Wright Whirlwind-powered craft used on the flight. Flags representing all the 22 countries visited have been painted on the port side of the plane. The cruise was made in three days more than four months and no mechanical difficulty of any sort was experienced. Note Cuban insignia on tail.

THAT CUBAN "Good-Will" FLIGHT

On the 448th anniversary of Columbus' landing in the New World, wings were spread over the Americas to again carry the torch of freedom.

by Douglas Clifton

On the Light Plane Tarmac

PRIVATE FLYING AND WAR

WE ARE hearing a lot of driveling these days about the possibility of all private flying being banned if and when this country goes to war. We see articles in practically every aviation magazine in which the writers bitterly assail any move the Government might make to curtail private flying if war actually comes and American airmen have to take command of the skies.

Most of these statements are made by those most vitally concerned. Many of the articles rapping this possibility are written by men who just "happen" to have jobs that rely on private aviation or by authorities whose work depends on the control they have over private aviation.

These angles are understandable, of course, when we realize that the abolition of private flying will do these people out of their remunerative jobs. With them on that score we can have sympathy, but when the security of the nation is at stake certain sacrifices must be made.

Most of those who are already fighting something that hasn't yet happened argue that we shouldn't ban private flying because that would abolish the Civilian Pilot Training plan. This is the one hook on which they all hang their arguments. But it is the most ridiculous argument of all, because no matter how they present it the C.P.T. is now a war measure and not a private pilot's financial heaven. The C.P.T. plan is as much a war measure today as is the building of battleships. The only part that is really "civilian" about it is the fact that those who are fortunate enough to get an appointment are civilians when they start, but we must realize that practically all of them will end up in the Air Corps.

If war is actually declared tomorrow, the C.P.T. plan will automatically become a national defense measure and as military as they can make it, and anyone who does not believe this must be Pollyanna's old man.

The Government air training programs in Germany and Great Britain became out-and-out military organizations the minute war was declared, and it *can* happen here. Hiding our heads in the sand and trying to argue that it won't is simply dumb cussedness.

Anyone who believes the C.P.T. plan was designed to teach young college boys to fly so that they could all go home in the Summer and buy a Piper Cub to canter about the countryside with—and nothing else—need their noggins attended to. The plan was just as much a military defense measure as those previously established abroad by the other powers. Here we didn't annoy the Joe College lads with details of machine guns or the innards of bombs as a side-line, but we were training them for national defense just the same.

So the ban on private flying, if war comes, will in no way affect the Civilian Pilot Training program. It will be here and working just the same, only we shall be calling the conscripted—pardon, inducted—members Flight Cadets instead of Bill and Jim.

There can be no private flying if war comes. The private pilot will have no place in the air when we have the sky scheduled for military aircraft programs. Can you imagine a few civilian planes darting about somewhere over New York City while the fighters and bombers are carrying out their daily patrols? And who is going to keep track of these private planes flying from one part of the country to the other, getting in the way and quite possible getting news and views of national defense that are none of their business? It would be very nice, of course, if we could all use our private planes and take-off just when a dog-fight is taking place somewhere near Sandy Hook or while a dive-bomber belonging to the Navy tries to bop an enemy submarine off Block Island.

Knowing the commercial interests

as we do, it is easy to see how some smart promoter would soon be running air excursions out to see the battles in the skies for so much a head—and there will always be plenty of curious dopes in the world who will pay real money to get there. If you think this is stretching the facts, don't forget that one steamship company actually planned a special tour to South America with a promise of a front seat at a naval battle when the British had the *Graf Spee* bottled up.

THERE CAN be no private flying during a war because of the nature and transportation ability of the instrument involved. Look at the possibilities of the whole situation. Suppose some ex-Axis individual held a legal pilot's license and had a plane. What would stop him from doing a little quiet bombing on his own? What would prevent him from flying over Washington, or New York, or Brooklyn, or any of our aeronautical firms and dropping bombs and scuttling away into the night? How are you going to differentiate from actual marked enemy and the enemy within if you allow private flying to be carried on during war-time?

We are wide open enough as it is. We induct thousands of young men into the Army. We put them into camps, surround them with all kinds of important equipment, and keep them under rigid supervision. Then we open the whole camp every week-end and allow thousands of fond mothers, fathers, and sweethearts to roam all over the place—and many who are not so fond could deposit germs or bacteria in the drinking fountains, vermin in the bedding, or even poison in the food. There are probably enough enemy agents roaming our military encampments every week-end to wipe out every man who has been inducted into the service during the last few months.

Now we have the same dreary mob trying to kid the Government into allowing private flying during war-time. The possibilities of such a situation make the mobs at the military camps seem like mere pranksters.

But to be very serious about the private flying business, let us really try to see it in a sane light. It should be clear to all that if this country is involved actively in the present war, it will be impossible to allow private pilots, no matter what their standing, to be free to fly out of any airport in the country. There can be no supervision over planes in the air if they are not under full control of the military authorities. Private flying in war-time is definitely out. We have



Better visibility and higher speed is claimed for the Bellanca Cruisair by substitution of the 100-h.p. Lycoming for the usual radial.

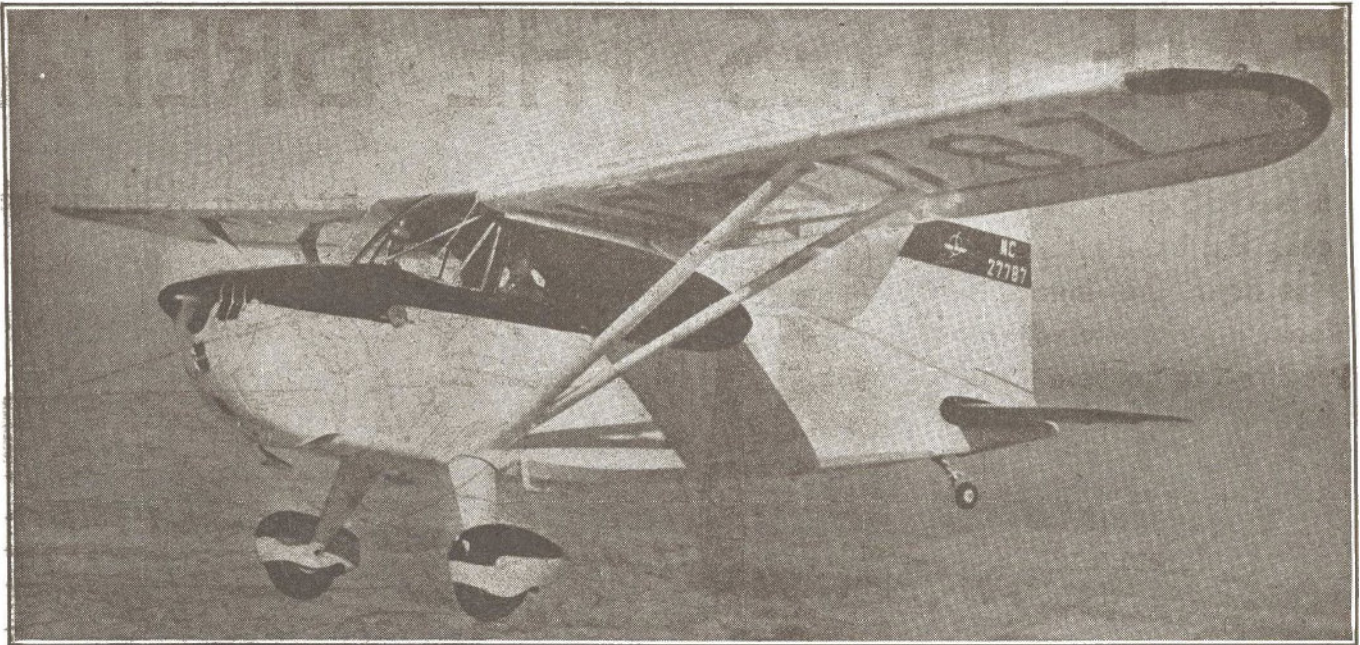

Stinson's latest is called the Voyager. The ship is equipped with an electric starter and is an improved version of the 105. Power is supplied by a 90-h.p. Franklin, giving 115 m.p.h.

enough trouble keeping a check on the ordinary individual who has access to the train, airliner, or automobile without allowing him the use of his own wings. One has only to sit down for ten quiet minutes and think of all the things one bird could do in a month with a plane and one grim idea.

No! Private flying is out during war-time. The factories that build private planes will be busy turning out Government trainers or parts for Government machines. It will be impossible to fly in war-time except as a military man or on military duties.

But private flying will progress just the same. Many men will have been taught to fly, and when it is all over they will be back on the private fields trying to get a hop or even putting some of their pension money into private planes. The war—if it comes—will give a new impetus to private flying and we shall all take advantage of it. The lull, from the private point of view, will do plenty of good for the business. It will give us all a chance to get a new perspective on the sport—and above all appreciate it again when the drums have stopped beating.

It is probably just what we need. We have all become a little too blasé about the appeal of private or sport flying.

NEWSY NOTES

MAYBE WE ARE doing something swell in this light plane business after all. We note now that the Piper Company is producing the new Coupé with a 75-h.p. plant, an engine starter, and a built-in radio. Oh, well, several years ago we asked for a 75-h.p. light plane that was fitted with a

radio and other safety devices. Now, at last, something really constructive is being done in this line.

We notice that a well-known light plane test pilot who has put more than 2,000 machines through their paces always wears a parachute. He has never had to "take to the silk" as yet, but he keeps snapping the straps when he climbs in and he'll probably be around a long time.

Have you seen pictures of the new Ariel light plane which is powered with the Lycoming 65? She's a new style low-wing monoplane and is supposed to land at 40 and climb 750 feet per minute. Her cruising speed is 105 m.p.h.

You photo fans can win yourselves five bucks and a gold lapel pin for just getting a nice original shot of a light plane that bears a Lycoming engine. The snap must have pictorial interest and, if possible, include one person as well as the plane. Send prints to the editor of the *Lycoming Star* "Snapshot Contest," Lycoming Division, Aviation Manufacturing Corporation, Williamsport, Pa.

WATCH YOUR WIND!

OUR LETTER this month is something different. It comes from Wayne L. White, of Decatur, Ga., and has a real lesson for all you who may have reached that stage where you became a little careless. You know, one of the best air instructors once said: "I don't fear for the beginners in this racket. It's when they get 100 hours under their belts that I begin to worry. Then they know everything and they seem to get into everything—the wrong way."

At any rate, here's White's letter, and it requires no further explanation.

Light Plane Editor:

I have been an ardent reader of *FLYING ACES* for years, and your articles on light plane flying were the original inspiration for my learning to fly.

I took my instruction on a 55-Taylorcraft and at the time of the incident I am about to relate was flying the same ship. My instructor was ex-

(Continued on page 74)



This new Ariel light job can be had with three different engines—Lycoming, Continental, or Franklin. Top speeds, in order: 115, 125, 127.

FATE FLIES THE BREDA

It was just an ordinary tin can. But before the day was done, that innocent-looking red container was destined to cause a lot of trouble for Coffin Kirk.

CHAPTER I

SINGAPORE BOUND

IT HAD BEEN rather simple getting away from Kabong on the eastern shore of Datu Bay. There, Kirk and Tank refreshed at the District Commissioner's office and their plane had been substantially refuelled for the hazardous trip across the South China Sea. Kirk figured on anything, of course, but since his route was dotted with small islands that still flaunted the flag of the Netherlands, he expected no real trouble.

The high-speed Breda was still giving her revs and turning out the mileage as per catalogue. Her 1,000-h.p. Fiat engine was ticking over with little or no effort. They had their cockpit hatches back to get a little real air into the pit, and on the whole things did not add up too bad.

They had to keep cool, for they were carrying something mighty important that had to be in Singapore within a few hours and in the hands of Rear-Admiral Jessop of the American Asiatic Squadron now berthed inside the harbor of Singapore.

It was the red can Tank had snatched from the water not an hour before that had Kirk more worried than all the possible hindrance the Japs might provide.

They were ramming on at about 4,000 when the thunderclap of opposition hit them. It was sudden and unexpected, and Tank was somewhat to blame for it all. He had been snoozing aft in the back seat under the spell of the speed and the blinding glare of the tropic high noon.

The Japanese Navy Kawasaki fighters were on them before they knew it. The first burst spanged into their wing and beat a hellish Highland fling on the dual panels before Kirk sensed what was up.

He yelled at Tank, and that muscular worthy swung around hard and somehow managed to get the rear guns out of the domed cover of the fuselage. He went through the motions of loading with slow and deliberate movements. Kirk reacted with

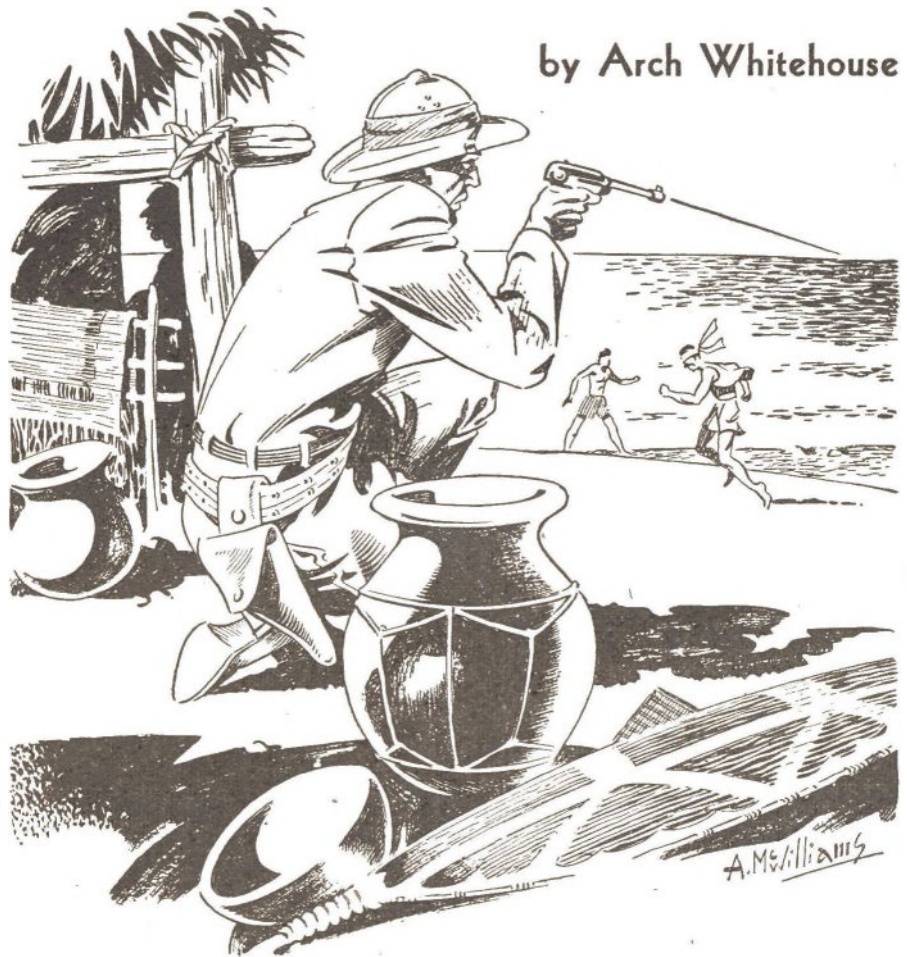

by Arch Whitehouse

all the electric snap of a master swordsman. He brought the Breda around on a wing tip and went hell-for-leather smack-bang into the center of the Japanese formation and split them wide while his Breda-Safat guns screamed and slashed into the blunt-nosed Kawasakis. Kirk treadled his way through, and his quadruple jets of death sprayed and slashed with venomous hatred through struts, radiator shutters, and bellies of the Jap jobs.

Tank managed to get his weapons chattering, too, as they roared through the winged menace formation. He simply held the trigger-release down and let the laws of ballistics take their course.

With so much lead being spattered off, something had to go. Two Kawasakis grunted through their ports, gushed a belch of flame and smoke, and then exploded with a dull metal-muffled roar and scattered their parts in all directions.

Kirk brought her over hard again, was on the tail of another in a few seconds, and again his guns snapped and jetted out blinding flame, and drew lines of yellow hate across the sky. He yelled over his shoulder at Tank, who was still blasting away with his guns in any direction he could see Japs.

"Take it easy," yelled Kirk. "Don't

waste 'em, Tank, old fellow!"

The gunner guy held off dumbly and then started in again when they were ramming full tilt through the broken Kawasaki formation.

TANK WAS the distinct opposite to Kirk. He was squat and broad. He had long arms that reached below his knees, and his clothes seemed to have been selected from a masquerade costumer's. He had the face of an ape. It was heavy and broad and alarmingly wide across the frontal bone. There were strange tufts of hair under the eyes. The nose was practically Mongolian, with heavy, red-rimmed nostrils. There was a strange unreal pinkish glow across the cheeks which somehow seeped down into the beard line of the lower jaw.

They slashed in and out and then tried to run for it because Kirk was smart enough to know that there is a law of averages somewhere.

"Just hold them off, Tank," he said. "I'm getting out of this until we get rid of that red can."

Kirk hammered the Breda through and tried to run for it. The Japs reformed and rammed after him, their front guns slamming leaden hail all across the sky. Kirk made the most of his speed and skill with the stick, while Tank sprayed the opposition

Just as Tank legged from his rear pit, another hail of fire came at the Breda from the fringe of the native village!

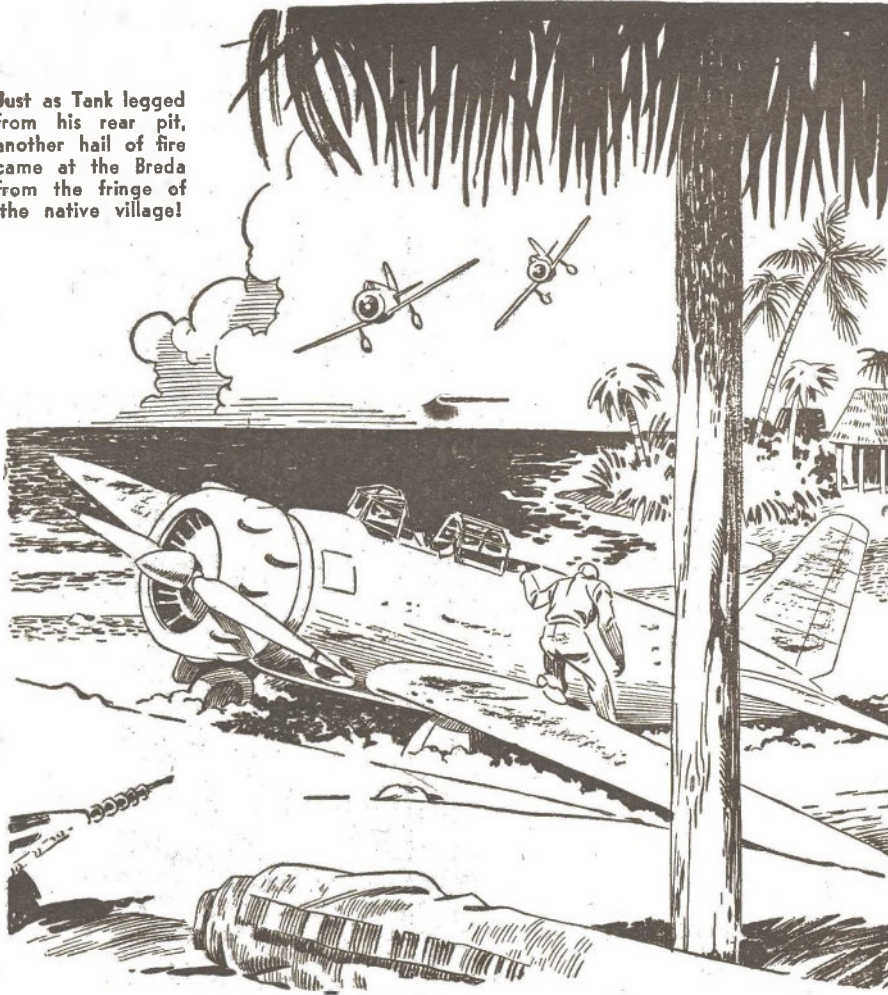

with everything in the belts.

But as Kirk feared, the law of averages caught up with them. A long-range burst caught their wing tip, trickled across the panel, and pounded a short drilling of lead into the wing-root. Kirk tried to get her over, but the damage was done. The wing-root spurted fuel as though some strange power was putting the pressure on the tanks, and it came out in a honeycombed stream.

Kirk looked around and saw that the red can was still securely laced to the framework near the cockpit ventilator lower. It was there to keep cool, because inside was mighty susceptible to heat and cold. If it got too hot—well, it was all over.

He hurled the Breda through a series of wild gyrations while Tank peppered away in shorter bursts. The gunner guy sniffed and peered out over the cockpit and saw the spraying fuel going over the tail assembly.

He grabbed Kirk's shoulder and pointed and made strange noises to show his anxiety.

"It's all right. We got a little left in the other side, Kirk explained. His expression was good enough for Tank who sniffed again and went to work with what was left in the belts.

Kirk glanced about and saw that he was fairly close to several small islands, but he decided to try and make one that looked somewhat larger than the others. He gave a quick glance at his chart and figured it was the larger of the Tambelan

group, which was about 300 miles east of Singapore.

Below, the South China Sea was a blue stew of Equatorial commerce. There were a few sluggish freighters, a line of four native copra vessels, and far off on the horizon the black smoke of a Blue-Funnel Line steamer.

Kirk twisted back and forth and decided to make a last stab at getting away. He knew how much fuel he had available and intended to run his luck to the limit now.

First he swung around and bashed the Breda suddenly at the three Kawasaki fighters that were trailing half-heartedly. He poured out several long-range bursts and made them turn. Then he stalled, brought the nose up, and let her fall off. The Breda started to spin and went down slowly in a series of slow gyrations. The Japs turned back and saw the Breda going down trailing a plume of black smoke. Each thought either of the other two must have put in a telling burst, and perfectly satisfied with the result they swerved off and headed north.

Kirk waited, and when he was down to within 500 feet of the water he brought her out carefully, rammed her nose around for Tombelan, and set a course for the eastern shore of the larger of the group.

They contacted the island in about twenty minutes and Kirk took the long chance again and cruised up and down on the last few quarts left in the remaining wing tank. What they

saw was none too enticing. There was a beach of sorts littered with debris, rotting logs, and all the rubbish of a tropic shore. There were a few clearings here and there where strange heavy timbered houses seemed to be teetering on massive stone bases. They were decorated in gaudy native colors, but the roofs which were high and steep-pitched were covered with very modern galvanized sheet iron.

Kirk selected a stretch of beach near this compound, brought the Breda around into what wind there was, and worked her down to a landing position. He was just setting her for a glide-in when suddenly a series of shots echoed from the rim of the village.

Kirk instinctively banked to clear, but it was too late. The last gasp had been drawn from the tanks and she conked cold.

"Hang on, Tank!" Kirk ordered. "Hang on!"

He drew the Breda over and stuck a wing-tip down. He was wondering where those shots came from and why, when she hit with a sideslipping motion like a great broad-bladed knife slashing at the sand. The machine dug in, cartwheeled over and over, and came up with a clatter of metal and hollow boomings. Kirk remembered reaching for the red tennis-ball can and then passed out cold.

Tank, who was tossed clear like a shapeless ball when the Breda cartwheeled, somehow landed on his feet and began to snuffle and thump at himself in a wild rage. He jammed his comical hat down lower over his head, and with heavy ponderous stride he rumbled forward toward the piled-up Breda.

WITH LOW, throaty growls and strange whinnying noises coming from his broad nostrils, Tank went to work on the wreckage to get Kirk out. With his hairy hands he ripped a great chunk of dural wing panel away and hurled it across the sands. Then he clambered across the shattered wing-root and pawed over the battered fuselage which was already flickering with flame and being obliterated with black smoke.

He wrenched at metal H-section stuff and twisted it as though it had been hot taffee. He pulled and battered until he had an opening. He screamed, bellowed, and ripped man-made framework to shreds until he was able to get at the man he worshipped.

"Take it easy!" Kirk yelled from his uncomfortable position.

The gunner guy peered in, saw that Kirk was apparently okay, and began to rip the fuselage apart. He was frantic and wild in his gestures even though he could see that Kirk was still alive. The flame was still licking out from somewhere up from near the engine, but it was not a very serious fire, because Kirk had somehow pulled the emergency fire extinguisher which was smothering the flame with a sudsy mess that was frothing from the firewall bulkhead.

Still, Tank continued to struggle and growl as he fought to take the Breda apart. Kirk finally rammed himself into a sitting position and raised his arms so that he could pull himself out. He rested amid the wreckage while Tank tugged to get him clear.

There was a strange gleam in Kirk's face as he leaned down again and fumbled around in his cockpit. The flame gushed up once more and a belch of smoke seemed to douse it all. He ducked down again inside the wreckage and then clambered out.

The fire had consumed itself, but the Breda was a total wreck.

By this time a motley gathering of brown-skinned natives was swarming out of the compound, over the sand dunes, and from out of the nearby jungle. They were strange, sleek-haired men with heavy breech clouts around which were drawn decorated *kris* belts from which hung bangles made from leopards' teeth. Some wore leather bands about their foreheads decorated with amulets and wisps of tiger hair. They were none too tall or inspiring as physical specimens. They came up in small batches, clacking and excited. They moved in closer and Tank clambered out of the tangle of wing to move forward and inspect them. He was sniffing loudly, making low crying noises, and his long fingers clenched and unclenched with strange pulsating emotion.

"It's all right, Tank," Kirk said soothingly. "Take it easy."

Then suddenly out of the tangle of men and the garish glare of native costumes, there appeared a chunky man in European tropical whites. He wore a dirty pith helmet and had a heavy unshaven face that presented nothing that might be interpreted as friendliness.

He came up with a dull swagger, looked the wreckage over and then gave Tank a real up-and-down. Tank in turn looked as though he would relish the opportunity of tearing the intruder apart.

"I am the Dutch government Controleur here," the man said directly to Kirk. "You have reason for landing?"

"One of the best in the world," came from Tank's direction. "We crashed."

The Dutch official stared at Tank as though he could hardly believe his ears.

"I was not speaking to you," he scowled. "I was asking a question of your master."

"If you're a Dutchman, you must have lived many years in Hamburg. You certainly have a Hamburg docks accent," the gunner guy seemed to say.

The Dutchman trembled under his baggy coat and appealed to Kirk. "We do not expect lack of respect. You are foreigners?"

"No. Just Americans," said Kirk, piercing the man with his cold eyes.

"We were on our way to Singapore." "Singapore?" the Dutchman repeated. He seemed to tremble again. "If you were going to Singapore, I shall have to inspect your machine for contraband."

"We're carrying nothing you would drink," came from Tank's direction.

Actually, it was Kirk saying all these things, because Tank was an ape and Kirk was a skilled ventriloquist. He often used this method to study his man, and this time it was certainly working.

"Before you do that," said Kirk, "I have an official complaint to make. We were fired on while landing. That caused us to crash! Do you know anything about that?"

"Of course not. But I must get on with my inspection. I'm sorry to bother you."

"You're not bothering me," smiled Kirk. "You're just wasting your time. You won't find what you want."

The Dutch official turned and stared at Kirk as if he were unable to understand just what it was he had said.

"Go ahead," taunted Kirk. "You'll find the tin, but it won't contain what you think."

CHAPTER II

MITSUBISHI MENACE

THE DUTCHMAN clambered up through the wreckage and made his way into the cockpit with the air of one who knew just what he was doing. In a few minutes he came out with a charred can about nine inches long. It had once been painted red,

but flames had scorched the paint to a brownish black. He stepped back and inspected it and watched Kirk's eyes as he twisted the lid.

"We have to search for contraband," he said again.

He took the lid off and peered inside.

"Melted, eh?" smiled Kirk. "It got

too close to the fire."

The man peered inside again and held the tin so that the sun shone inside and disclosed a brownish melted substance. He put the lid on, smiled grimly, and tossed the can back into the cockpit. "I was afraid it was opium," he said, his eyes in adder folds, "but I guess it was just some sort of wax, eh?"

"Looked like it, didn't it?" Kirk agreed. "Now what about this shooting business?"

"I'm afraid that was some of the natives. They must have been frightened by the sight of your plane. They fire at anything."

"Do these natives have German-

type machine guns in their belts?"

"German guns?"

"Most certainly. Here's one of the slugs. That's from a German weapon, isn't it?"

Kirk held out a battered slug he had taken from the wreckage of the plane. The Dutchman picked it out of his hand with fingers that had nails in mourning and inspected it closely. Then he dropped it back with an air of disdain and said: "Looks like an old Martini-Henry bullet to me."

"I suppose you'd take a 9-point-2 for a Winchester 30-30, if you were in the mood," Kirk said. "That's a Rheinmettal-Borsig slug and you know it."

"I know nothing of the sort. I'm the Controleur here and I object to any criticism of my administration. I know these natives well and I know they have very few weapons of any kind—except knives."

Kirk sensed that there was no use arguing with this man. He wasn't Dutch at all. He was obviously German and he was on the island of Tambelan for something more than a holiday. He had gone straight to the crash for the red tennis-ball can, and he was satisfied that he had found it and that the wax record he believed to be inside had melted in the short blaze. That meant he was most certainly in touch with Koji Yasui, the Japanese Secret Service agent who had sworn to prevent that can and its contents from reaching Rear Admiral Jessop.

"What do you intend to do now?" the Controleur demanded.

"Can I contact Singapore?"

"Of course not. There's a war on and we can't use the radio here."

"You are supposed to have an ocean telegraph connection with Dutch Borneo or Sumatra."

"That was cut weeks ago by a German raider."

"How do you get mail out?"

"On the supply steamer. It gets here about once a month—when it's running. I doubt whether it will arrive for another three weeks."

"Well, I'll get to Singapore somehow, if I have to rebuild this boiler," said Kirk stolidly.

"You could wait for the steamer. There's no particular rush, is there?"

Kirk knew he was simply saying: "Since you have lost the dictaphone record, what can you want to go to Singapore for in such a rush?"

"I'll get the radio set out of the ship and try to re-rig it here and get a message through. I guess they can get someone here for me in time."

"In time?" the Controleur asked curiously.

"I have to get out of here fairly quick. You see, I'm afraid my government has called me up for service and I want to be on hand in case any soft jobs are going."

The natives had moved in closer now and Tank was studying each one in turn and fingering their decorations while they stood stock still, peering into his ugly mug.



"Won't you come up to my hut and rest?" the Controleur suggested. "You must be badly shaken up."

"I'll go up and have a look around," said Kirk. "I'll leave my man here to guard this mess until I decide what to do."

"That's a good idea."

"You have examined it all you care?" asked Kirk.

"Oh, yes. Just a routine, of course," the Dutchman explained lamely. "I believe you understand."

"That's right. I quite understand," smiled Kirk as he started to follow the man up the beach. "You stay here, Tank. Keep an eye on that mess."

The ape apparently replied: "Watch that Dutchman! He has dirty knees and doesn't go to Sunday School!"

The official frowned and stared at Tank, but finally managed to assume a pose of disdain and started off Kirk said: "You mustn't mind him. He has a strange knack of presuming the worst in everyone. Sometimes, however, he's right."

"He's an insolent oaf."

THE DUTCH Controleur led the way through the strange Tambelan village which was composed mainly of teak and rushwork houses set high off the ground on heavy timbers. The main street was paved with gigantic slabs of stone and there were ceremonial platforms and sacrificial altars every few yards. At the far end, facing down the main courtyard, was a larger structure which had at one time been the house of some chief, or it might have been a temple years before the white man had taken over. The lower story was ranked with a series of heavy wooden columns and inside were a number of stone seats and platforms. The Dutchman led Kirk up a ladderway staircase into the second floor which was walled off with gayly decorated panels and slabs of mahogany that carried fantastic carvings. Around the walls were planks set shoulder high which had a series of wooden pegs beautifully carved and decorated.

"These are where the Tambelans used to mount the heads of their enemies," explained the man. "We have tried to clear all that up and bring civilization here."

"Civilization backed up with Rheinmettal-Borsig machine guns," taunted Kirk with a grimace.

"You still believe you were fired on from here?" the Dutch official demanded.

"I know I was, and you know it too."

"I'm sorry if you feel that way, but I must insist that you have made a mistake."

"Look! We were fired on a short time ago by some Japanese naval planes and I happen to know all about their Nambu guns. I know a German slug when I see one, and I heard the gun fire."

"I'm afraid you are quite upset.

Know America's Planes

NUMBER FOUR

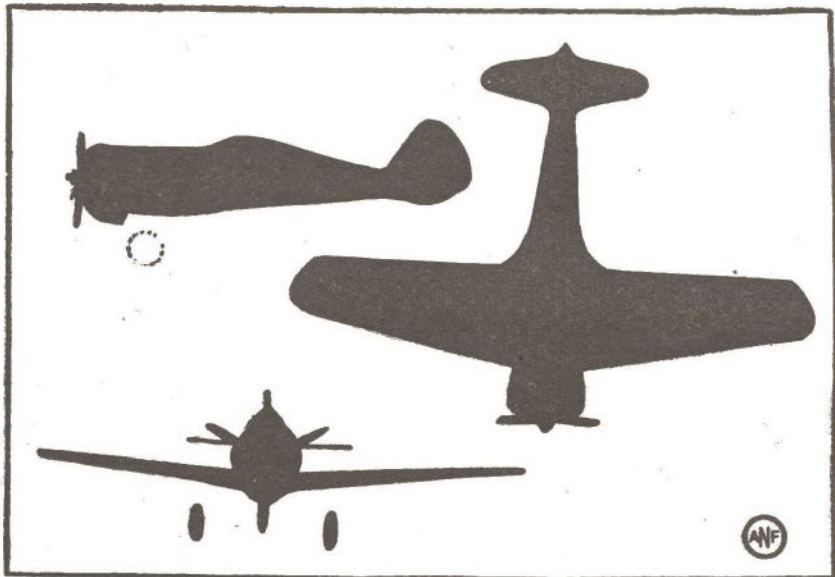

IT CAN climb a mile, almost straight up, in 60 seconds—can the Curtiss-Wright 21B interceptor, three silhouette views of which appear above. Small yet formidable, the 21B symbolizes the amazing range of military aircraft now being produced in the United States—from light trainers to the world's largest bombers. Note in these sketches the "teardrop" design—rounded nose and sharp slope toward the tail structure—and the "overhang" on the lower side of the engine, which are characteristic of the 21B, a ship designed primarily to intercept invading bombers.

According to company publicity, the 21B has a "guaranteed" top speed of 333 m.p.h. in level flight,

which probably means that the actual maximum is quite a bit more since exact figures are very rarely given out on military machines. It is also stated that accommodation is provided for four machine guns, but there is no word as to their placement.

The editors of FLYING ACES did a bit of tracking down on this machine and discovered that it was for export and was not built for U. S. competitions. With further checking, it was found that the ship is probably for Great Britain, since the company neither affirms nor denies the point. In any event, it is more than probable that the craft will eventually wind up in the RAF, now that Bill H.R. 1776 has been approved.

Come into my office and I'll get you a drink."

The Dutchman stood aside and pushed a heavy door open. Kirk went through, seeing a normal office with a desk, tables, and gaudy chairs over which bright lengths of hand-woven tapestry were thrown. Kirk sensed too late that this was a trap, but before he could turn or make a move to defend himself something exploded a mine on top of his head.

Lights flashed out and then a dull leaden cloak of darkness settled down as he sensed he was going to his knees. He tried to recover but the blow had been a cruel one and gradually the motive power in his muscles and limbs oozed out somewhere and he lay there in a numb spell, subconsciously realizing that his hands and feet were being tightly bound. The effect of the blow gradually bathed him into a nerve-throbbing sleep and he slipped away into the Land of Black Dreams.

The Dutch official had two of his Tambelan natives drag Kirk into a large closet where he was stowed away, and then he opened a carved teak cabinet behind his desk and disclosed a very modern radio panel. He snapped a battery switch, selected a call letter from a card hanging from a hook, and began to tap a brass key. He continued tapping for some minutes and then listened intently for a reply and confirmation.

"They'll all be here before darkness," he muttered. "Now to go back to the beach and take care of that other ruffian."

But Tank, who had taken Kirk's order with an animal's sense of intuition, had watched Kirk move away and disappear with the Dutch official into the maze of huts that made up the village. He stood near the wrecked Breda for several minutes after his Boss had left and then began mooning up and down, glaring

(Continued on page 68)

Behind Factory Doors

The sweat and toil that goes into making an airplane doesn't show when a ship is in flight or on the apron. To get the inside story of those weeks of most exacting work, one must go behind the scenes in an aero plant.

by FRANK MACKAY

Below: Slowly, a night worker pushes open the doors, giving outsiders a glimpse of what goes on inside the Boeing Co.'s Seattle factory.



EVERYONE KNOWS that airplanes are constructed and don't "just grow that way," but unless you've actually worked in an aircraft factory you can't appreciate what that "constructed" really means. Buildings of all types, furniture, and thousands of other things come from the direct effort of man, but airplanes are definitely in a class by themselves. To the aircraft factory employee, the warplane is a clock-like mechanism, a work of art to be marveled at, and represents a long, drawn-out, tedious job.

We hear much these days about Germany constructing 2,500 ships a month, the plan put forth by Henry Ford, Walter Reuther, and other individuals for the building of 500 planes a day, and shortage of both material and labor. To the lay public, things of this sort cannot be understood definitely and they reason that planes should be as easily and as rapidly fabricated as automobiles, clocks, vacuum cleaners, or other sundry everyday and household objects. As a matter of fact, many aero en-

Below: Interior of the Stratoliner. The many formers are fastened together with flanged stringers before the skin is riveted in place.



thusiasts who have never seen the inside of a factory also reason along these lines, so here we'll try to throw off that cloak to some extent and take you through a factory to show you what's done on an average ship.

FIRST OFF, a design is created, the first model of which is submitted to either the Army or Navy as an experimental type. That is a story in itself, however, so we will just take for granted that a type has been ordered and that production is under way.

The factory is usually divided into three main sections—primary, sub assembly, and final assembly. It is the duty of the primary department to form the various component parts from raw metal. Sub assembly then gets these units and pieces them together, and later they are turned over to final assembly to be actually installed or mounted in the airplane moving down the line. Let's take bulkhead Number 4 in a Republic P-43 Lancer as a representative product.

The metal worker has plans passed out to him by his Leader, or straw boss. He then thoroughly acquaints himself with the blueprints and procures necessary material from the stockroom. He may be working on only one small unit of the bulkhead, the other pieces being made elsewhere in the factory, but he goes about his business, knowing that when the many various sections are eventually assembled they will form the desired structure.

On work of this type, tolerances are usually no more than approximately one sixty-fourth of an inch and checks must be made constantly to be sure that the work is going smoothly. Also, if the mechanic is working with Alclad or any other aluminum-coated metal, he must be extremely careful not to damage the surface of the sheet; even the slightest of scratches is sometimes enough to cause a piece of work to be rejected.

Necessary rivet holes are drilled after primary work has been completed, and then the piece goes to Inspection. Here it is stamped as to number and checked thoroughly against plans and templates. In most cases, both company and Government inspectors check the work. If the unit is passed, it goes to the Dispatch Table and the route card is marked for various treatments and stockrooms.

On his rounds, the stock chaser takes the unit first to the Wash Room, where it is completely cleansed of ink and pencil markings and hung up to dry. The Wash Room clerk stamps the route card and the unit is then taken to the Paint Shop by the stock chaser. Here, it is sprayed, dried, and checked again by inspectors, and then dispatched to the sub assembly stock-

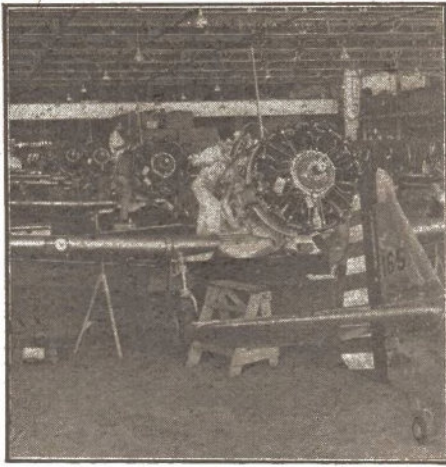

Moving toward the field. Skilled mechanics at North American's plant rush Air Corps AT-6A advanced trainers along the final assembly line.

room where it goes into a special bin. Sub assembly workers requisition the part and rivet it in place on the bulkhead. Then it again passes through Inspection, the Wash Room, the Paint Shop, Inspection again, and to the final assembly stockroom. At last, it is again requisitioned and placed in position in the ship just forming at the far end of the assembly line.

That, however, is only part of the story. Some units must be heat treated three or four times, to make them soft enough to be worked into shape. They may then be either anodized, sand blasted or cadmium plated, according to the metal and the part it is to play in the airplane, and may then be later withdrawn from the stockroom for reworkings if alterations in design are made—and there are plenty of them.

THE HAMMER ROOM is one of the noisiest sections of an aircraft factory. Here, cowl sections and other pieces are shaped by incessant pounding by trip hammers. This work requires the utmost skill and only a thoroughly experienced hammer-operator can turn out perfect work.

Drop hammers are also found in the Hammer Room. With these machines, a male form is dropped onto a female form upon which a piece of sheet metal has been placed. The male is dropped several times until the piece being worked is formed perfectly. It is then dispatched by stock chasers to the primary department to be finished, and thence to Inspection, the Wash Room, the Paint Shop, Inspection again, and finally to the sub assembly or final assembly stockroom.

To make the male and female forms for the drop hammer, the unit to be made is first molded by special workers. Molten metal is poured into these forms to make the rough die. This die is then cleaned up in the Machine Shop before finally being numbered and placed in its respective bin in the Hammer Room.

Immediately adjoining the Hammer Room in many factories is the

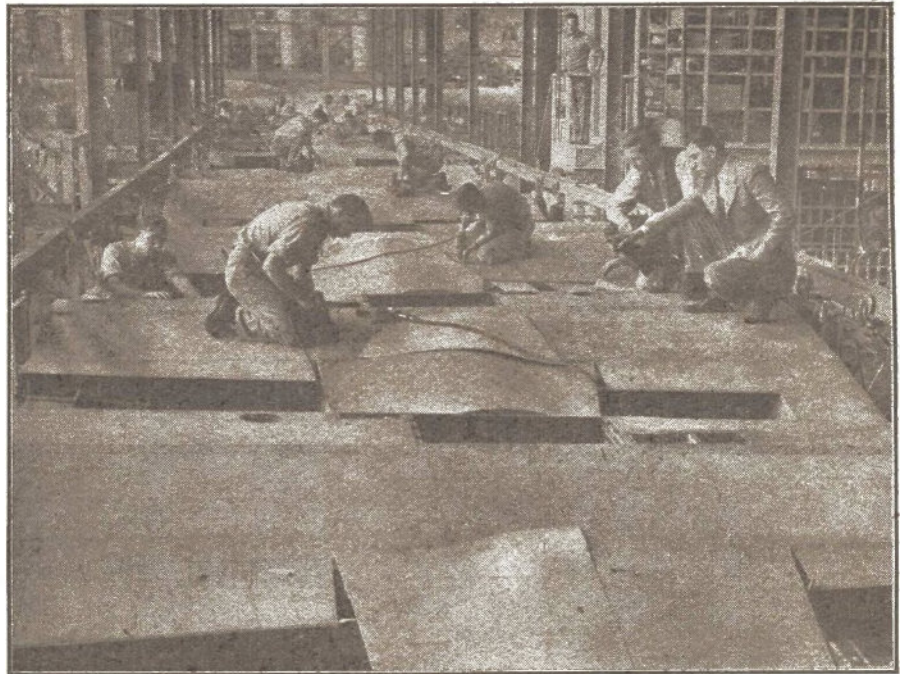

Two men are required when driving rivets with a portable machine. The bucker holds a block of hard metal against the rivet's clinch end.

Oil Treat Room. This department is usually an extremely messy place in which to work and as a rule doesn't have any too good an odor because of the warm oil used.

Rods utilized in various parts of the plane are always treated with oil to prevent internal corrosion from taking place. In order to do this, a hole is drilled into each end of the finished rod. Oil is forced into one hole under pressure, and then both holes are plugged with rivets after most of the oil has been drained out. The piece then follows the usual routine, going from the Paint Shop to a stock room.

Up to 10,000 individual units are used in construction of the average single-seat, all-metal fighter. Some of these parts are so small that they would actually seem to the layman to be unnecessary. However, they have been found to be more than important and in most cases cannot be eliminated. As a matter of fact, the company would, if possible, do away with as many of these small sections as possible, because they are not only troublesome to make and treat but are also difficult to store and handle because of their size.

These 10,000-odd parts—minus the engine, of course—are held together by some 50,000 rivets which are in most cases hand-driven. As many as 36 different types of rivets are used in various parts of the ship. These also receive many different treatments. First off, they must all be inspected before use and then anodized. Then, before being used, they are heat treated and stored in dry-ice refrigeration boxes to prevent them from becoming hard again before being driven. If a rivet is kept out of the refrigeration box for any length of time without being driven, it must

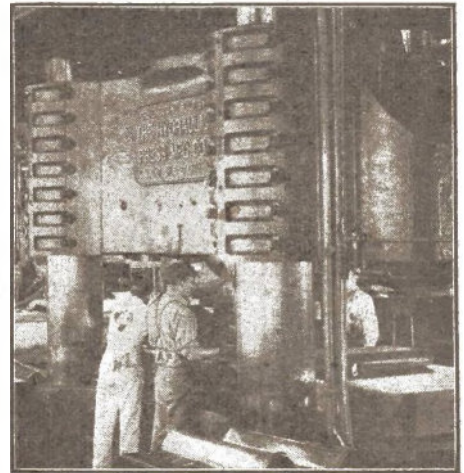

Huge hydraulic presses are now being used in order to speed up production and eliminate as much hour-killing hand work as possible.

be heat treated again to make it soft enough to be worked.

When using a hand machine, two men are required for driving a rivet—the riveter himself and a bucker. The bucker holds a piece of steel behind the rivet, to clinch it, while the riveter hammers the head of the rivet with his machine.

Some aircraft manufacturers have realized the thousands of man-hours wasted every year by riveting, and have turned to spot-welding. By this principle, sections and skin may be fastened together and in place much more quickly than by the old method. The unhandiness of the riveting method may best be illustrated by a point recently brought on in connection with the Douglas B-19 bomber, for it was stated that some rivets are so difficult to reach that they are clinched by exploding small charges of powder behind them. Henry Ford, the motor magnate, also understands that the current system is not suited to mass production methods, and he recently announced that his en-

(Continued on page 79)

In the Slipstream

New Warplane Christenings

Those names the British give our exported planes fascinate us somehow. Figuring you get a boot out of them, too, here's the latest list, with the Limey tags in italics: *Bell Caribou* (Airacobra); *Lockheed Lightning* (P-38); *North American Mustang* (NA-73); *Consolidated Catalina* (PBY-5); *Consolidated Liberator* (B-24); *Martin Baltimore* (B-26); and *Martin Maryland* (167). Meanwhile, Reader Conrad Crespot says he won't be satisfied until one of those jobs gets dubbed *Hohokus* in honor of his home town in Jersey.

Not So Hot

Now we're told that our total plane turnout will only be 37,000 by the Summer of '42, which isn't so hot. The unofficial February figure was a mere 1,130 planes, showing what a snooze has been going on in our industry. Production really *could* be sparked up. But *will* it?

Poles Have What It Takes!

Hats off to those remarkable Poles! Their transplanted air force, now assigned to a big stretch of Scottish coast, is stronger today than when Hitler attacked their own country. One Polish squadron has accounted for more than 150 German planes. In fact, Poles form the largest body of allied airmen in England, whereas you'd expect the flyers of nearer Nazi-trampled countries to hold that honor.

Power Plant Notes

Considering our lack of liquid-cooled engines, it's good news that Allison will be delivering 1,000 a month by late Fall. The current figure is 350 per. Incidentally, Allison has designed a 24-cylinder X-type plant to develop 2,000 h.p. And Chrysler says it has a liquid-cooled 12-cylinder V-type on the way which is expected to do close to that same h.p. with the use of a super-octane fuel.

We Deplore—

(1) Those big aircraft companies which keep talking about defense bringing "financial risks and possible losses to our stockholders." They're making more jack right now than they've ever made. Besides, the really important subject is *turning out more planes!* And fast! . . . (2) The failure to achieve real production standardization. One concern is making two different models of the same plane—because the British use one kind of engine on the job in question while our Army insists on another. . . . (3) Our lack of enough airports. As NAA Prexy Wilson points out, no real force of modern pursuits can be flown across the continent due

to the lack of fields. In fact, the Army has had to check on golf courses as possible sit-down spots. . . . (4) Continued sale of huge quantities of gasoline to the Japs by American firms. Sure, we've taken over Thailand-headed dive bombers at Manila for our own use, and we've sent Consolidated warplanes to Singapore. But Nippon, if it fights us, will fly against us with American fuel.

We Applaud—

Representative Kramer, of California, for drafting a bill requiring airliners to provide passenger parachutes. Flocks of investigating committees and safety serenaders have been pouring out so-called words of wisdom over the sad fact that we've had five airline crashes since August 30. But Kramer is the only one of the lot with enough savvy—and courage—to talk 'chutes, which *do* save military and private flyers' lives, and which *can* save passengers' lives. True, the use of "the silk" won't be practical on airliners until certain technical and structural details are worked out. Well, who's stopping 'em from working 'em out?

"Over There" Notes

With American flyers arriving steadily from Canada, a second Eagle Squadron has been formed in England. . . . Most of the warplanes which were top jobs last Fall are playing secondary roles in the Spring sky battles, better planes having taken their place. . . . Sinking of the Royal Navy's 1937-made cruiser *Southampton* by Nazi dive bombers in that recent Mediterranean scrap marks the first complete loss of a modern armored warship by air attack. In short, it can be done. . . . Wonder if by the time you read this the Jerries will actually have invaded England in a slew of those highly-touted super-gliders reported capable of carrying 50 soldiers each? . . . Germany has lost 4,250 planes and Italy 1,100 since the war began, according to a British Air Ministry statement in early March. England's own losses were put at 1,800 craft. Hitler insists, however, that his sky-men have really knocked off 3,784 RAF machines.

Defense Angles

More than 5,000 CPTP airmen have gone into our Air Corps. . . . The War Department is strengthening Philippine defenses by addition of two more air squadrons, and six sky outfits are going to a new base in Alaska. . . . That mammoth Douglas B-19 bomber was supposed to have been test hopped back in December, but at this writing it's still on the ground. Mr. D. hasn't let on what's been wrong. . . . Aircraft plants

have been hiring a total of some 5,200 men weekly. . . . Besides chute troops, the U.S. is developing air infantry. Well armed and equipped, these A.I. lads will train to fly behind enemy lines in transport craft. "Vertical surrounding," you know. . . . A certain model British anti-aircraft gun so impresses our experts that it may be adopted by us. . . . Army primary-flying training contracts have gone to 11 additional air schools. That makes 28 all told. . . . The Reuther plan for mass production of planes in unused auto factories is still being considered after all, for it's said the scheme will play a part in building bombers.

Bits About Flyers

Jimmy Doolittle has been sworn in as a flying cadet. We hasten to say that a "Jr." belongs after that name—for this time it's the famed racing pilot's son. . . . That celebrated gal flyer, *Phoebe Omlie*, is now Senior Private Flying Specialist for the CAA. Her job is to direct a program to train men for ground crews. . . . Among *Eddie Rickenbacker's* well-wishers after his recent airline crack-up was the German 1918 Ace *Ernst Udet*. A war-transcending friendship! . . . *Prince Bernhard*, of the Netherlands, is learning sky-scrapping with the RAF. . . . The world's first military airman died the other day. He was *Brigadier General Fred-eric Humphreys*, U.S. Army aviator who flew solo 'way back in 1909. . . . Major Lord didn't accept that RCAF commission after all. If things go right, it will be the U.S. Navy instead.

On the Lighter Side

Won't somebody please give our radio announcers some aviation lessons? Broadcasting from the Lockheed field the other aft, Ken Carpenter cried: "A P-38's right over us now—just listen to those powerful *Douglas* engines!" . . . Our idea of big news: An aero company that *isn't* expanding. . . . Dangling cables of runaway British barrage balloons recently put more than 90 Danish electrical stations on the fritz. Maybe if Britain let all her rubber sausages loose Hitler would holler for peace. . . . An unnamed Missouri farmer takes the prize this month. He wants the airliners "to quit flyin' over my place because the weight of the air supportin' the planes may collapse my frame buildings." . . . Rumania's air ministry recently had to punish itself for violating its own blackout regulations. . . . And word's come out about an AA plane that made a forced landing because of an engine nacelle "fire"—which turned out to be not flames but some fluttering bits of tape!

Gimmicks and Stuff

Bullet-proof glass for warplanes has been devised by Aero Engineer Horace Alter. Reports say it'll snub a .50-cal. slug even at 100 yards. . . . Selsyn Indicator is the name of a new
(Continued on page 66)

PROBABLY the most publicized and propagandized airplane in the world is Germany's Messerschmitt Me. 109. Ever since its appearance in 1937, and its later setting of a new landplane speed record of 379.66 m.p.h., it has been subject to a constant flow of writing in practically every newspaper and magazine in the world. Some of these have been propaganda, some speculation, but few have given actual and authentic facts. I have disregarded all information that appears the least bit vague or shaded and have instead relied upon authenticated facts in the preparation of this article. In all possible cases, aeronautical engineering formulae and principles were applied and conclusive results obtained.

Professor Willy Messerschmitt is one of the world's foremost designers and has always had a reputation for developing fine aircraft. Some of the forerunners of the Me. 109 were the

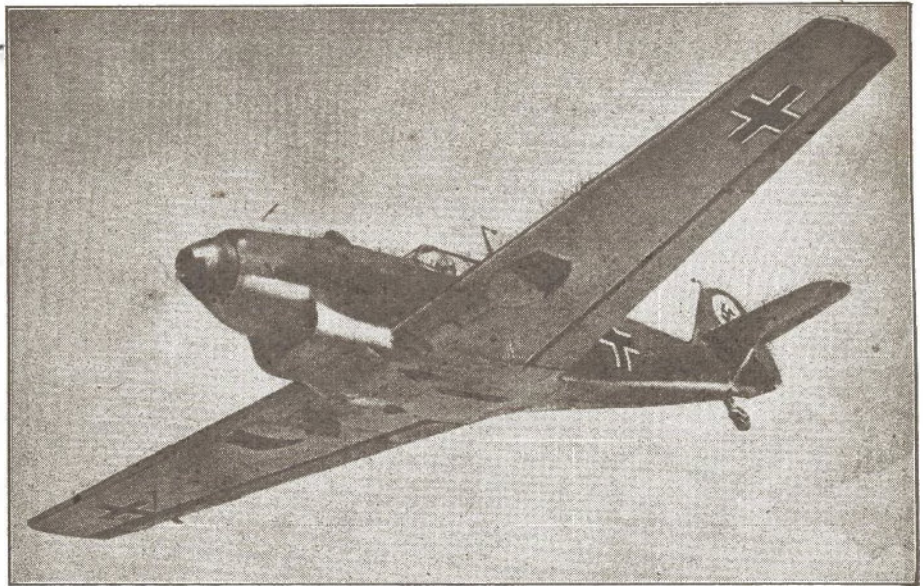

No. 2 of the series was powered by the Daimler-Benz DB-600.

ME. FAME—FACT OR FANCY?

M-29, M-35, and the Taifun.

The original B.F.W. 109 was of composite construction—steel tubing fuselage, fabric covered; metal frame, fabric-covered wing and empennage—but was later changed to all-metal construction. In general, the Me. 109 is an all-metal, low-wing monoplane with retractable landing gear. Span is 32 ft. 6 in.; length is 32 ft.; Gross weight is 5,520 pounds; and empty weight is 4,180 pounds.

Nucleus of the structure is a frame to which is attached the landing gear, wing mounts, and part of the motor mount. This method of construction is responsible for the plane's adaptability to mass production. The wing is of stressed-skin construction and is of the hinged trailing edge type. Handley-Page slots, used for the first time on this type of plane, are incorporated into the leading edge. The tail surfaces are all-metal, stressed-skin, with fabric covered control surfaces. The stabilizer is mounted rather high on the fin and may be moved up or down to trim the ship, since no trimming tabs are used. It is braced to the fuselage by two streamlined metal struts.

The fuselage body is stressed-skin monocoque in construction with the nose section covered by removable metal cowling plates. The cockpit cover is hinged on the right side instead of sliding on tracks. Immediately behind the cockpit is a steel mast which has the two-fold duty of radio aerial post and nose-over pylon. The main fuel tank is behind the cockpit and two auxiliary tanks are located in each wing root behind the landing gear well.

The radio receiver and transmitter are placed in the rear of the fuselage between the cockpit and the tail, and the antenna extends from the main

The highly-vaunted German 109 is here stripped down piece by piece and its secrets revealed.

by J. B. Rust

post to attachments on the tips of stabilizer and rudder. The oil tank is to the rear of the firewall in front of the instrument panel. The cockpit is fully equipped with oxygen apparatus.

There are at least three different versions of the Me. 109, powered by as many different engines. First, the model using the 640 h.p. Junkers Jumo which saw service in Spain and which the late Frank Tinker said was inferior to the Russian planes used by the Loyalists. Performance of this machine was: Top speed, 310 m.p.h.; cruising speed, 254 m.p.h.

The second version of the 109 uses the Daimler-Benz DB-600 of 950/1,070 h.p. This model was produced in large quantities for the Luftwaffe and is still in general use. Its speed is from 323 m.p.h. to 334 m.p.h., depending on the horse power available.

The latest model uses either the Daimler-Benz DB-601 of 1,150 h.p. or the Junkers Jumo 211 fuel-injection engine of 1,200 h.p. Powered by the former the performance is: Top speed, 354 m.p.h.; cruising speed, 298 m.p.h.; landing speed, 75 m.p.h.; ceiling, 36,000 ft.; cruising range, 621 miles. Top speed with the Jumo is 367 m.p.h. Instead of the tunnel radiator under the nose, this model has a small retractable radiator and two small radiators on the underside of the wings.

Maximum speed of all versions of the 109 is given in the following table. They have been obtained

through the use of performance calculation formulae and may be considered accurate:

Engine Used	Speed
Jumo 210 640 h.p.	310 m.p.h.
DB-600 950 h.p.	323.86 m.p.h.
DB-600 1,070 h.p.	334.37 m.p.h.
DB-601 1,150 h.p.	354 m.p.h.
Jumo 211 1,200 h.p.	367.45 m.p.h.
DB-601a 1,360 h.p.	388.57 m.p.h.
DB-601a 1,800 h.p.	468.92 m.p.h.

THE ME. 109 has been called a plane lacking in maneuverability by many writers, but this is not entirely true. The Messerschmitt is noted for its ready aerobatics *in the hands of a capable pilot*. Its poor showing in battle is the fault of poorly-trained German flyers. It is interesting to note that both Al Williams and Major Seversky have examined the Me. 109 first hand and both attest to its being a first-class fighter.

A comparison with other aircraft in its class will show the Me. 109's true qualities. There exists a mathematical formula for just such comparison, and it was applied to the Me. 109, Spitfire, Hawk 75A, and the Vultee Vanguard. The results follow:

GENERAL EFFICIENCY FACTORS	
Me. 109	7.1
Spitfire	9.4
Hawk 75A	6.5
Vanguard	12.2

(Continued on page 80)

JERRY PRISON SCAMP

CITIZENS of Boonetown, Iowa, wonder about Phineas Pinkham at times. The great ace of World War Number One gets moody and locks himself in his den at home or in his office at the novelty factory and remains incommunicado for hours at a time. Mrs. Pinkham and her son Philo are at a loss to account for the breadwinner's sporadic isolations from the outside world, for as far as they knew Phineas never had a conscience. "Pa generally goes into these spells," Philo told reporters from Des Moines, "after he reads certain kinds of war news. I guess the ol' man landed too many Spads, dead stick, and it's beginnin' to tell on his noodle."

Let us look in on the forty-three year old novelty magnate as he sits in his swivel chair and devours a well-known pictorial weekly. There are pictures of the boss of Adolf's Gestapo and of Himmler's plug-uglies standing over frightened citizens whose only crimes were to have been born without Teutonic blood in their veins.

"I wish I had never joined up in 1917," Phineas sighed. "Himmler, that bum, sure went far and all because of a prisoner of war named Johnson. And here I am maybe the cause of the second world guerre. It is sometimes too much for me to stand."

Phineas flipped the pages and came to some pictures of Hitler and Benito keeping a tryst in Brenner Pass.

"I could have caused that, too," Phineas groaned. "Maybe the Eyetalian would have fought with France an' England if I'd never flown

For one very good reason, Phineas didn't want to be an officer any more, so he switched duds with a buck named Johnson. But the pride of the Ninth soon got fed up on the doubling duty, and found out that, after all—it's the Phineas that counts!

by Joe Archibald

that new Spad. Well, I must snap out of it as I have a family to support."

A knock came on his door. Phineas got up, crossed the room, and unlocked his sanctum. His secretary stood looking at him with eyes a little jittery.

"Well?" Phineas snapped.

"A salesman to see you. Has samples of the stock you need to make those exploding slugs. His name is Donald Gillis."

"Send Bump in," Phineas said and he sat down and let the memories of the past inundate his mental assembly and sweep him back over the currents of time to dump him into the compartment of a Frog twentieth century limited rattling over the rails between Bar-LeDuc and Pareae. It was the year 1918. . . .

* * * *

"AH," LIEUT. PINKHAM sighed as the iron horse pounded over the rails, "If it wasn't for leaves, what would trees an' aviators do, huh? Haw-w-w-w-w! And the bums back there have to fly at four in the A.M. They should try and git medals more oftener like me and they would git let out for recess. Boys, it is peaceful."

Phineas sat back and wondered about one thing. Not many hours be-

fore, he and Howell and Bump Gillis and two other Spad drivers had encountered a batch of Boche over the Meuse. Three of the Jerries were flying Fokker D-7's and the other circus performers had crates that looked a lot like D-7's but which refused to act like them.

"I could hardly believe it," Phineas mumbled to himself. "We had a couple of them Heinies ready for the next world when they went up fast and was out of sight close to Heaven before we could spit. Well, I will not worry about them. There is either kangaroo or jackrabbit blood been put in Kraut petrol. But why should I fret as I am on my way to Pareae. Oh-h-h, Maddymoselle from Armentieres—parley vo-o-ose! She eats them snails and wears no shoes—parley vo-o-ose!"

Thump—kerthump—bump!

The train suddenly stopped. Phineas got out and stepped onto the free soil of France. A Frog brakeman was swearing.

"Ze tracks are pulled up by ze Boche flyairs, bah-h-h-h-h! We have to wait until zey are feexed an' eet weel take almos' ze apres midi! Voila! Sacre bleu!"

"I will take a promenade in ze countree for a while," Phineas said. "Blow ze wheestle when the train is goin' to commencez-vous encore. Ah, ze countryside ees smell so magni-feek!"

Lieutenant Phineas Pinkham strolled along for an hour. He finally rounded a bend in the road, saw something in the middle of a cow pasture that knocked him back on his heels. There was a battle wagon the like of which he had never seen before. It reminded him of a Spad that had out-stripped its classmates. It was a winged prodigy. Three men stood around the crate and they were gesticulating with all the gusto of as many David Harums.

"Bon jaw," Phineas greeted the trio when he reached the plane. "That is some crate you got."

"You are ze pilot, non?"

"I am, oui. Ze name ees—" Phineas was a cautious character. There was a possibility that something might happen here and if it did not prove to be something good, well, he was not



The Bugatti-Spad knifed between two trees and broke a souped-up Hisso's speed as it shed its wings and headed for the boneyard!

"Handen hoch!" the German guy grunted, aiming his bayonet at the Pinkham empennage. "Mach schnell, schwein!"

going to give his family history. "Ze name ees Lieutenant Cuthbert Heathcliff. Two hundred an' twenty-third Pursuit Squadron."

"I am M'sieu Laval," the Frog said. "Mon ami here ees Signor Bugatti who designs zis Spad. I help to finance ze sheep an' eet should revolutionize ze war in ze air. But zis so dumb pilot, he say he can fly an' eet ees maybe he meant ze enfant's kite, oui."

"Bah!" said the airman who stood near. "Take ze sheep an' make out of eet ze tank. Eet ees too heavy."

"We follow in ze Renault," Laval said. "We see zee Spad start to go down before he ees two miles from ze fiel."

"Shoos," the swarthy man with Laval said. "She's a one gooda airplane, bambinos. Everything I poosh 'em up the bes' I know. Two-seater with two bankos of eight cylinderos each, shoos. Water-cooled an' she shoots one pouno shells besides having two Vickers an' two Lewis gunos. Bes' in the air or I'm a sonamagum."

"The undercarriage is as low as a duck's belt buckle, huh?" Phineas said. "Boys, that is some crate. So maybe she is one good pilot yoa need to fly eet, oui?"

"Voila!" Laval exclaimed. He was a short squat little citizen with an epidermis as dark as Signor Bugatti's. "Eet gives fifty francs if you test heem out, Lieutenant."

"An' fifty lire," tossed out Bugatti. "How many pounds an' marks?" Phineas grinned. "Well, that track won't be fixed for another two hours, so here goes, mon amies."

PATCHWORK QUILTS are made out of bits of bright cloth that come from all over. We have to shift the scene and go to a British air-drome at Montmirail. On the beef and kidney drome stood a Kraut Rumpler with members of the RFC grouped around it. Two Limeys were bundled up in air togs and were getting ready to board the alien sky scooter. The squadron commander's face was grave.

"A rum go, old chaps," he admitted. "Lots of time to change your minds."

"Tish tush, Major," a King's loyal subject scoffed. "A blarsted cushy job if you arks us, what, Bertie?"

"Rawther, old thing."

It was a rum go, right enough. Brigade was worried about the new Kraut ships that could outclimb the fastest of the feathered friends. Germany threatened to change the aspect of the war in the air just when it seemed that the British S.E.5 had the Boche stalemated.

Under the RFC flyers' sky burlap were Jerry uniforms that had been filched off the torsos of the luckless Rumpler crew. The idea was that the British were going to try and steal a pepped-up Fokker D-7 right out from



under the Krauts' bugles. Impossible? Maybe. Leander swam the Hellespont. David licked Goliath. And Hannibal, hampered by elephants, crossed the Alps.

"All Allied ships in the sector have been warned, men," the Limey C.O. said. "They'll watch out for that bit of cloth attached to your tail. Have another go at some brandy, what?"

"No thanks, old chap. Smell of brandy on the lips of Hans Augerspiel and Leutnant von Seidlitz would make the Boche wonder."

"Smart chap." The C.O. grinned and shook hands with the Rumpler crew. "Haven't forgotten the German you learned at Oxford, old chaps?"

"Nein, mein herr. Gott strafe England. Ha!"

The Rumpler went up into the blue sky and pointed toward the lines.

Back to scene No. 1: Lieutenant Phineas Pinkham, after listening to some words of wisdom from the spaghetti merchant, managed to get the Bugatti-Spad off terra firma and nurse it upstairs.

"What a buggy!" Phineas gloated. "With an observer in it, I could lick what is left of the Kraut circus. A cannon, too, like Rene Fonke had in his Spad. Sixteen cylinders an' all purrin' like sixteen cats with a mouse inside each. Why didn't they send for that Eyetalian before? Oh, if I ever

see a Boche ship, I will not have a bit of will power."

The Rumpler flew on. So did the Bugatti-Spad. They came within five hundred yards of each other over Epernay.

"Well, as I live an' breathe as good as I can with a pair of bellows that won so many sprint races," Phineas howled. "A Rumpler! Not another crate in the sky. Oh-h-h man! We will see how this crate acts bein' baptized. Have at 'em my hearty!"

Phineas' sixteen cylinder Bugatti-Spad circled the Boche observation crate like a tribe of Comanche ringing in a covered wagon in the old west. The crew of the Rumpler tried to wave Phineas off for a while, then the Limey observer started to throw punches with the Boche Spandau.

"Oh, you decided to stop kiddin' me that you was out of ammo or somethin', huh?" the Boonetown pilot howled. "Well, how is this for apples, you Boche bums!" He let his Vickers go and silently thanked Bugatti and Laval for having thought to load the guns. The Rumpler shuddered like a ducky who has suddenly been confronted by a ghost near a cemetery and fell off on one wing.

Bullets spat into the Bugatti-Spad and Phineas backed away before starting a quarter attack.

"The cannon!" Phineas suddenly yelled. "Why not?"

Now Signor Bugatti should have told Phineas one more thing before he had let his pilot take to the high places. He had found out that the pilot's seat in the Bugatti-Spad would have to be pushed back a little to allow for the recoil of the cannon. The French flyer had been warned about that, had been told to draw himself in at the bread basket a little before letting go with the 37 mm. shell.

Ba-a-a-ng!

"Oof!" Phineas choked out and let go of the stick to caress his solar plexus. He was robbed of the sight of the Rumpler going down sans an empennage. In fact, he found himself only six hundred feet from the ground when his breath was back into his bellows and the black curtain had been withdrawn from in front of his goggle-glass. He had to act quick to save what was left of his future.

The Bugatti-Spad knifed between two trees and broke a souped-up Hisso's speed as it shed its wings. The body skidded into a patch of blackberry bushes, went out the other side, and dived into a very slimy pond where bullfrogs were being housed by a citizen who furnished the best frogs' legs to Paree hotels.

Phineas crawled out of the mess, scraped lily pads off his fuselage and prop boss. A big croaker sat on each of his shoulders and sung in his ears.

"Oh, that Frog and that Eytalian will be sore," Phineas gulped. "But I got that Rumpler as I know I had a bead on it when I let go. It won't work, though. Pilots won't last long enough shootin' that cannon. Bugatti will have to work on that. Oh-h-h, my stummick! Well, they will be lookin' for Lieutenant Cuthbert Heathcliff, Haw-w-w-w-w!"

Phineas removed his clothes, dried and cleaned them. He took off his dogtag and put it into an inside pocket in his trench coat. Toward dusk he started reconnoitering and at last he came within sight of a little Frog hamlet not far from Epernay. A sign-post said: **LA-BELLE FRANCE. Troisieme Kilos.**

THERE WAS one estaminet in the town. A few Limeys, Frogs, and Yanks stopping over there for one reason or another. Phineas walked into the oasis and got himself a snifter. He took it to a table where the light was dim and sipped at it. Conversation slapped against his face, and finally he heard a name that lifted him half out of his chair. His undercarriage began to quake.

"Name was Heathcliff," a Britisher said. "The Leftenants said he flew a Spad they never had seen before. They was dragged out of the wreck two miles from here and were they

swearin'. They wanted to know why Brigade didn't tell everybody about the Rumpler. They said they'll see the King about it."

"Yeah. An' they said the crate that shot 'em down was not feelin' so good the last they saw of it," another soldier said. "They got a description of Heathcliff an' are sendin' it all over. He will git shot if he is picked up. The Limeys were going over to steal one of them new Fokker D-7's that can go up faster'n a blinkin' barn filled with shavin's. Somebody'll git his pants burned."

Phineas' drink tasted like wormwood with a dash of cobra saliva in it. Description? He paid for his drink, got up and ambled nonchalantly out of the bistro, his fabric oozing fretting vapor. He brushed shoulders with a tough looking M.P. and almost



The frantic Frog had fished up plenty of francs for the factory, and he threatened to get hunk!

collapsed right then and there.

"Oh-h-h, what've I done?" Phineas moaned as he hugged the shadows. He lurched into a narrow street and bumped into somebody.

"Pardonny maw," Phineas gulped.

"'Snuthin,' ol' pal of mine," a voice said and arms went around Phineas. "Maybe you come from the Bronx, huh? So maybe it givesh a feller from the east side. Look, buddy, only yesterday a hun'ed bucks comes from home. The Johnsons ain't no pikers. You an' me will spend it. Eashy come, eashy go! Papa has the biggest delicateshen in Bronx. Whoope-e-e-e-e!"

Phineas wanted to run but his brain channels were getting as busy as the subway back in the Bronx.

"Follow me, buddy. Know where we can get van blank moch cheaper," Johnson said. "Full of offishers, anyway, the bummers. I hate offishers, don't you?"

"Yeah. They are poison to me right now," Phineas had to admit. "Lead on, MacDuff."

Phineas followed Private Joe Johnson into a cellar and there he saw six barrels of forgetting juice. He got a good look at the dough in the light from a candle. Johnson got a good look at him.

"You're an offisher. I am framed," Johnson yelled. "You will turn me over to the M.P.'s an'—well, I am a lawyer an' will beat the case. Lishen, pal, I wash kiddin' about offishers."

"I am no more an officer than you," Phineas grinned. "I borrowed the uniform and am havin' fun. I been walkin' into estaminets all over an' slappin' fatheaded brass hats on the back an' callin' them names. It's more fun!"

"Ha! Ha-a-a-a-a!" Private Johnson yipped. "Boy, would I like to be an officer for five minutes!"

"Haw-w-w-w! Here, have some more vin blank," Phineas said, handing a tin cup to Johnson. "I will lend you this uniform for an hour, pal. You got to bring it back, though, and, remember, you are Lieutenant Cuthbert Heathcliff, of the Pursuit Squadron between Luneville an' Monte Carlo."

Phineas removed all damaging evidence from his outfit before he handed it over to Private Johnson. The dough gave Phineas his entire wardrobe, including his dogtag and a letter from a fond mama. After another big slug of vin blank, Johnson left the cellar, clad in the raiment of an officer.

Lieutenant Pinkham had to work fast. There was nothing left for him in the war but the task of getting to a neutral country like Switzerland or Holland. The end, he told himself, justified the means. He must protect the good name of the Pinkhams if it meant hiding his identity until long after the war was forgotten.

"Adoo, old pals of Barley Duck," Phineas said as he busied himself with a little removable pocket he had taken from his ensemble. "Some day we will meet ag'in. I will always be thinkin' of you bums."

Phineas worked with freckle obliterators. He changed the contours of his nose somewhat with a special composition that would withstand heat and a certain amount of roughing up. Twenty minutes after Private Johnson had evacuated the cellar, Phineas was as frowzy as any buck in the Army.

Whistles started blowing and Phineas nearly broke into a run. P. P.'s blocked his path and one threw at him: "Okay, fishface, back to your outfit. Orders have come in to round up you mugs. Hah, you missed a swell
(Continued on page 75)

JOIN THE FLYING ACES CLUB

Honorary Members

President and Mrs. Franklin D. Roosevelt
 ex-Vice Pres. John Nance Garner
 Casey Jones Rear-Admiral Byrd
 Wallace Beery Col. Eddie Blakobacker
 Al Williams Colonel W. A. Bishop
 Col. Scorsal Major G. A. Vaughn, Jr.
 Major von Schieleh Willy Coppers
 Lieut.-Col. Pissard Glenn L. Martin
 G. M. Balkans Walter H. Boehch
 Capt. B. Seegienky Zack Motchy
 John K. Northrop Duane L. Wallace
 Colonel Roscoe Turner Josef Vejhens
 Charles W. A. Scott Col. A. P. de Soversky
 Richard C. DuPont Donald W. Douglas
 Maj. A. W. Stevens Major C. C. Mesoley
 Capt. G. A. Anderson Clarence D. Chamberlin
 Major Fred Lard Mrs. Charles S. Baylus
 Lieut.-Col. Theodore Roosevelt

Official Charters

F.A.C. Flights and Squadrons are recognized at GHQ only after they have received their official charters. These illustrated documents, printed on fine paper and portraying various features in the field of aviation, are excellent for framing and display. Their inspirational text is in keeping with the high ideals and aims of our Club. Each charter application must include a full list of proposed group members and their addresses. Each of these members must hold his regular F.A.C. card, obtained by clipping and sending in the membership coupon printed on this page. If applications are approved, Flight Charters are issued for 25c, and Squadron Charters for 50c. Send the correct fee with your application. It will be returned if the Charter is not granted.

WIN YOUR WINGS

Save This Whole Coupon for
CADET OR PILOT
 insignia of the F.A.C.



Gold finish Actual size

All members with Official Membership Cards are eligible for Cadet Wings. This coupon, with two others and 10c, entitles members to Cadet Wings. Do not send this coupon alone. Save it until you have three. Then send them in all together with a self-addressed envelope and 10c to cover cost of wrapping and mailing.



Silver finish Actual size

All enrolled members who have won their Cadet Wings are eligible for Pilot's Wings. This coupon, with four others and 10c, entitles Cadets to Pilot's Wings. Do not send this coupon alone. Save it until you have five. Then send them all together with a self-addressed envelope and 10c to cover cost of mailing.

Send the Whole Coupon

regardless of which kind of wings you wish. Separate sets of coupons are needed for each insignia. Canadians send 15c, or three International Reply Coupons. Overseas readers send 1/-, or five Reply Coupons secured at the Post Office. Only one pair of either kind of wings to a member. If yours are lost, send 25c for new ones (2/-overseas). [61]

Do Your Full Share to Advance Aviation

TO advance the cause of aviation, over 50,000 men and women, boys and girls, have banded together to form the FLYING ACES CLUB.

It is the easiest club in the world to join. Just clip the membership coupon, fill out, and mail it to GHQ with a stamped, self-addressed envelope. Your official card will then be forwarded to you. After joining, you can quickly win promotion and the right to wear the various insignia of the Club.

In the FLYING ACES CLUB there are two kinds of local organizations, known respectively as Squadrons and Flights. A Squadron must have eighteen members, including its leader. A Flight must have a total of six. You can start either of these groups in your own community by enrolling your friends in the Club, then applying for an official charter as detailed in the column at the left. Each member must hold an F.A.C. card.

Meetings and activities are conducted among the squadrons and flights according to the wishes of the members. GHQ has established no rulings in this respect, nor are there any dues or red tape whatsoever. The entire idea of the Club is a common meeting ground in an international organization for the lovers of aviation in its various phases. Many local Squadrons and Flights hold regular contests and public events. Many hold weekly meetings for model building, and instruction, and even regular flight training.

Awards and the Aces Escadrille

After the membership card, and Cadet and Pilot's wings, comes the Ace's Star. This is awarded for enrolling five new members, using, of course, a separate coupon for each. As an Ace, you are then eligible for membership in the FLYING ACES ESCADRILLE. Then you may win truly handsome awards. Among these are the Distinguished Service Medal and the Medal of Honor, two of the finest decorations that have ever been designed.

Any member who has reached the rank of Ace is eligible for membership in the FLYING ACES ESCADRILLE, an advanced organization which replaces the old G-2 unit and opens the way for participation in a definite program contributing to the forward movement of aviation.

To enroll, an Ace must apply direct to Escadrille Headquarters, giving his name, age, address, rank, and highest award already won in the Club, and enclosing a stamped, addressed return envelope. If he is approved for membership his instructions will be forwarded. Membership in the Escadrille is limited to American and Canadian members only, at present.

For a Limited Time



Beautiful
STERLING SILVER
 F. A. C.
 Ring

ONLY 50c

We have on hand not more than one hundred official F.A.C. rings which are being sold, while they last, for 50 cents apiece. This beautiful STERLING silver ring is self-adjustable to assure a perfect fit. Formerly offered at \$1 apiece, the rings will be shipped post-paid anywhere in the U. S. and possessions to those whose requests arrive first. Take advantage of this excellent offer now. As a loyal Clubster you'll be proud to own one!

Keepers of the Log

In order to keep in touch with GHQ, every squadron should appoint a member with a facility for writing as Keeper of the Log. It shall be the duty of the Keeper of the Log to send in regular reports of interesting doings of his squadron. His is an important job, because it is only by means of interesting squadron reports that life can be given to the Flying Aces Club News.

Photographs, too, are an important consideration for the Keeper of the Log. Either the Keeper himself, or any other member with a camera, should keep a photographic record of the squadron's activities, for reference purposes, to show prospective new members, and to allow a selection of pictures to be sent to GHQ for reproduction in our monthly Club News pages.

The cost of film, prints, etc., would be a legitimate charge against the squadron's own treasury or could be covered by members' contributions. A number of flights and squadrons, incidentally, send us prints which have been taken, and completely developed and printed by foto-fan members of the outfit.

Correspondence

In all correspondence with GHQ where a reply is desired, enclose a stamped, self-addressed return envelope with your letter. GHQ receives thousands of letters weekly, and cannot undertake to answer those who do not heed this rule.

Official Supplies

Due to popular request, we have ordered a new supply of F.A.C. paper pennants. These attractive stickers, which have glue on the back so that they may be stuck onto car windows, etc., sell at 6 for 10c, or 20 for 25c.

We also have a new supply of swell embroidered wing insignia that'll look top-notch on your sweater. They're made of the official Flying Aces Club colors, blue and gold, and are available at 25c each. Order now before the supply is exhausted.

Overseas prices: Pennants, 20 for 2/-; wing insignia, 1/6.)

June Membership Application

I, the undersigned, hereby make application for membership in the Flying Aces Club. I agree to live up to its rules and regulations; to foster the growth and development of aviation; and cooperate with all other members in the work of spreading aviation information, building up confidence in flying for national defence and transportation. I will aim to build up the Club and its membership, and do my best to win the honors that the Flying Aces Club offers.

My name is
 Age [61]
 Street
 City State

Do you build airplane models?.....
 Mail this application, enclosing a self-addressed, stamped envelope. Canadian and overseas readers send the application, self-addressed envelope, and an International Reply Coupon worth 5c, secured at the Post Office.

FLYING ACES CLUB, 67 W. 44th St., New York

Flying Aces Club News

The good ship comes in and brings news from "Over There" . . . Don helps win a three year battle . . . Horace Chandler's big double thrill . . . Our swelling list of Escadrillions . . . and lots more!

by *Clint Randall*

National Adjutant, Flying Aces Club

EVERY FEW WEEKS a steamer reaches these shores with a few pieces of mail from our British Clubsters on board. Naturally, Headquarters looks forward to the arrival of these ships, as their mail always brings some interesting news and facts. Quite a few arrived at your N. A.'s desk the other day, so we'll start right off with a missive from Percy Chorley, of London, England.

Percy writes that he has been getting his issues through a subscription placed with us before hostilities began. Lately, he hadn't been receiving his copies and notified the magazine distributors, who in turn advised him that because of enemy action, copies of FLYING ACES could not be expected at their usual period. To his surprise, several days later *three* issues turned up—war or no war, good old F. A. had come through. And is Percy happy!

"First off," his letter goes on, "I want to tell you how pleased I am with the new streamlined form of

your magazine. It is a distinct improvement. And I'm so crazy about Alden McWilliam's style of drawing that I'm doing a series of them myself. I'm also copying a set of drawings of screwball Phineas. These will be used in decorating my 'penthouse' which is entirely Yankee. Also, in my room are models made from F. A. There's the Douglas gas job and 'Monoped,' to name a few. I intend going after your DSM, too. Tell the R. H. P. D. that I'm very grateful for his teaming me up with a swell McKeesport, Pa., pal."

Another letter from a British subject comes all the way from down under—Victoria, Australia, and was written by Kenneth Fishley. Ken says that he finds F. A. exciting and the model section interesting. He's built Scotty Mayors' "Kiltie Gull," and is now at work on the "Baby Sportster S-2." Ken would also like to have other F. A. Clubsters correspond with him and will promptly answer all mail. His address is 19 Princes Street, North Williamstown.

Now back to the U. S. A. to digest the contents of mail from F. A. C.'s here and there. . . .

"Do you remember reading an item in a back issue of F. A. about a young chap who was blind and then regained his sight?" writes Horace Chandler, of Camden Maine. "Well, I am that fellow. And while I've now had my sight restored, it isn't up to par of persons with good eyesight. Nevertheless, I made up my mind that I was going to start realizing my ambition and take lessons in flying. I went down to the local airport and had a long

Winner of the Distinguished Service Medal this month is Frank Kveton, of New York City. His "Moth" (August 1937 F.A.) was judged the best contribution of the month.



Seventy-odd years young, Bernarr Macfadden jauntily steps out of his Stinson Reliant which he flies solo. The well-known publisher is an Honorary Member and a strong aero booster.

talk with the instructor and told him how much I wanted to fly. He gave me a test, and even with my glasses my sight was not sufficient to warrant solo flying. We climbed into a Piper Cub, and after he was satisfied with my familiarity with the controls, up we went.

"Believe me, Clint," Horace continues, "it was the greatest thrill of a lifetime when my instructor signaled me to take over. I could make out the horizon and kept the nose and wings level. I put the ship in a gentle bank and turn and we flew around the airport until it was time to land. All this has certainly given me a new lease on life, so to speak—and if there ever was a real aero fan, it's me!"

You bet it was a thrill, Horace, and a double thrill at that. Seeing again and also being able to see what it looks like from up there was really *something*. We're rootin' for you, old man, and hope your peepers come around soon to be better still!

OUT OF A BATCH of letters comes word from Escadrille member Buddy Cook, of Los Angeles, Calif., who was just about to give up in disgust because the boys at his school weren't air-minded enough to start a FLYING ACES Squadron. "I figure there are other fellows around the country who are probably having the same trouble in trying to organize a Club," says Buddy, "so I think it would be a good idea if we all band together as independent members (certainly not by our own choice) and form a sort of nation-wide squadron via the mails. We could tell of our activities, our accomplishments, and about our model building projects just as permanently based units con-



duct their activities.

"Boys on the farms and in other countries could join in, too," Buddy explains. "Information exchanged and even interesting friendships might result from these contacts. I would be very willing to print up copies of these letters which will be distributed to members in other cities. Also, when a member is visiting another city or town he would at least be able to feel free enough to look up the nearest member. I'm just waiting for your okay, Clint, before starting."

Buddy, that's a real fine idea. And it's plenty generous of you to take the time and trouble to print up the letters you mention. Clint hopes, though, that your burden will not take on such proportions that it will become too tough to handle. Sure you have our permission, and here's best wishes for success! Write Club Headquarters again in a couple of months and let us know how you are progressing. And for you F. A. readers who are in the same position as Buddy, you can contact him at 100 North New Hampshire, Los Angeles. And please enclose self-addressed, stamped envelope.

Terry Sonley, of 3 Olive Grove, Clinton St., Hull-York, England, would like to have F. A. Clubsters everywhere to write to her. Terry has been a member of the Club since 1933 and has quite a service record.

Joe Boir, of Cleveland, Ohio, has been appointed editor of the aviation column of his high school paper, *Arc-Light*, and wants to know whether he may use certain portions out of FLYING ACES CLUB pages. It's all right with us, Joe. You have our permission to use anything you wish. Only thing is that you send us a copy of each column and give F. A. credit line.

We wrote about Kathleen McGee last month, telling how earnestly she is working towards promoting aviation. She was awarded a DSM, too. Well, today's mail brings a note from her with letters attached introducing

the latest Honorary Members—two outstanding personalities in the aviation game. They are: W. T. Piper, President of the Piper Aircraft Company, and William P. Lear, inventor of the Lear airplane radio-compass and other aircraft instruments. Welcome to the FLYING ACES CLUB! More points for you, Kathleen! Keep up the fine work.

Now we come to the naming of the Master Model Builder of the month. And this trip's winner is a chap who lives almost within a stone's throw of the N. A.'s office! Frank Kveton is the lucky lad, because his F. A. "Moth" photo was selected as the best contribution of the month. We're putting the medal in the mail for you

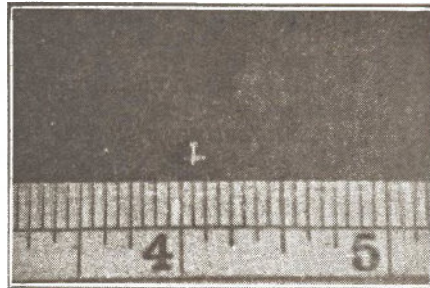

John Clarke, of Victoria, Australia, kept his promise. He actually built this $\frac{1}{8}$ "-span NA-33 "Wirraway."

pronto, Frank. Wait till you see it. It's a honey!

Now, for the benefit of those who are not familiar with the proper procedure in entering our contest, all you have to do is this: After you've built a model from plans appearing in any issue of FLYING ACES, haul out your camera and pose the ship so that it looks pretty right in the view finder. Don't depend on one shot; try others from different angles. When the roll is developed, one of them might be a winner. It's fun, fellows. Try it. Mail any amount of photos you wish, state the name of the ship and from what issue the model was built. Address letters to the DSM Contest, FLYING ACES CLUB, 67 West

Clubster Malcom Shipman, of Queens, New York, uses his bike as a retriever when his Brown-powered gas job starts out on cross-country trips.

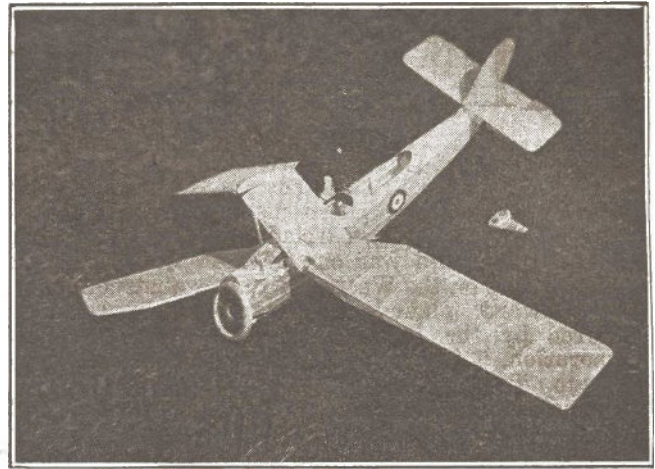

"She was coming in for a landing under perfect control. Suddenly, a wing dipped, she lost flying speed, and . . . ooooph!—she skidded to a stop right at my feet," writes Clubster Leslie Hicks, of St. Cloud, Minn. The model is a Blackburn Shark, famed torpedo carrier of the RAF.

44 St., New York City. Wing Commander Dave Cooke, Model Editor Jesse Davidson, and Adjutant Clint Randall are the judges. Their selection is final and no photos can be returned. The winner's name is announced in every issue of the magazine.

AERO enthusiasts living in Dallas, Texas, interested in organizing a Flight should contact Clarence Meyer, Jr., at 2736 Alabama Ave., . . . Arthur Gloster, of 43 Elm Street, Holyoke, Mass., wants all neighbors who are interested in forming a Squadron to write to him. . . Another Clubster who would like to correspond with active members anywhere is Henry J. Backowski, of the Air Corps Technical School, Chanute Field, Rantoul, Ill. Henry can supply long interesting letters on various phases of commercial and military aviation.

New additions to the Escadrille this month are as follows: Charles Burkhiser, Numa, Iowa; Don Shoemaker, Kenmore, N. Y.; Bob Roswell, Allendale, N. J.; La Mar Ganard, Shelley, Idaho; Kenneth J. Le Lacheur, Randolph, Mass.; Herbert Laurence, South Boston, Mass.; Bernard Freese, Beach, N. D.; Frank Dyszczyk, Everett, Mass.; Richard Neidenthal, Cincinnati, Ohio; Harold M. Carney Gananoque, Ont.; Edgar Hering, Worden, Ill.; Ben Reances, Gold Hill, Ore.; Paul La Porte, Dexter, Iowa; Charles W. Brimm, Creal Springs, Ill.; Harry Stone, Hastings-on-Hudson, N. Y.; Bill Schniederman, Yonkers, N. Y.; Chick Scheff, Athens, Ohio; Alex Rader, White Plains, N. Y.; Harry Gilbert, New York City; Allen C. Johnson, Newark, N. J.; Phillip Jerome, Youngstown, O.; Ben Fuller, Kensico, N. Y.; Cameron Price, Ashbury Park, N. J.; Ernest Toomey, East Lansdowne, Pa.; and Bill Malice, New York City.

Here's a letter from one of the most active model plane enthusiasts we've ever known. His name is Don Fuqua, of the Torque Flyers Club,
(Continued on page 67)



All Questions Answered

Clyde McKirdy, Gladstone, N. D.:—The S.E.5 was a British scouting biplane fitted with a Hisso motor. It did about 130 m.p.h., carried two machine guns, and was one of the finest fighters on the Western Front. The Howard planes are manufactured by the Howard Aircraft Corporation, 5301 West 65th Street, Chicago. The address of the Air Transport Association is Field Building, 135 La Salle Street, Chicago.

Valentine Brugger, Milwaukee, Wis.:—Sorry, but I do not have the details you require on the Consolidated 31.

E. A. Hood, Brooklyn, N. Y.:—As we have explained so many times, we cannot offer for sale any photographs reproduced in this magazine. We buy the pictures from regular agencies and therefore cannot sell them.

Keith Bruce, Stamford, Conn.:—We have a few copies of the issue you desire. You can obtain them for twenty cents a copy. Send the money to our Circulation Department.

Robert N. Theisen, Cold Spring, Minn.:—The autogiro was not designed for any special type of work. It was originally built as a new type of safety plane. It has since been produced as a commercial machine and many Air Powers are experimenting with it for army observation work.

John Goeller, Astoria, N. Y.:—Sorry, but we no longer have plans of the Griffon's Black Bullet available. There was such a demand for these that they soon gave out.

Tony Zickar, Box 549, De Pue, Ill.:—You say you have gas engines and stamps to trade for World War photographs. Well, perhaps some of our readers will be interested enough to get in touch with you. On that book question, I suggest that you ask your local dealer to try and get them for you.

Edward Dixon, Ridgewood, N. Y.:—The Siskin fighter has been out of production for years. The maximum speed of the Grumman F3F-2 is 270 m.p.h. The maximum speed of the Grumman F2F-1 is 237 m.p.h. Yes, mufflers create heavy back pressure in aero motors and thus cut down the available power, considerably.

Donald Davis, Onamia, Minn.:—Planes withdrawn from service are used by the Naval Reserve and National Guard units until they become

completely unfit. Then they are either dismantled or turned over to aero schools. No, you don't have to know anything about aerodynamics to build models from kits. Just follow instructions and you'll have a good ship. Do not mail negatives to the With the Model Builders department; just send prints.

Donald McLean, Arlington, Va.:—The new Lockheed P-38 is probably America's fastest military plane. But since we have no official figures on its performance, I can't tell you what it does.

John Hunter, Birmingham, Ala.:—You're right, we did make a mistake in the March issue when we said that von Richthofen was killed in a D-7. You and all the other readers who caught us on this, are correct. The Baron was flying a Fokker Tripe when he was shot down.

Robert Ernst, Ashland, Ohio:—Your chances for getting into the Air Corps will be more than even once you are in the Army, as you say you will be by June. After you get in service, you can take a competitive examination for the Air Corps. While this is quite difficult, it is still easier than the tests given civilians without college requirements.

Billy Dmuchowski, Chicago, Ill.:—From all reports, the Hawker Tornado is merely the old Hurricane with four more guns and a shorter wing span. It's difficult to say that the Spad was better than the Fokker, or vice versa, because each ship had both good points and bad points.

Dean Gray, Neenah, Wis.:—Both Major Fred Lord and Dr. I. Q. are right and wrong on that question! Of the two, however, Major Lord is more correct. The Air Corps states that in order to become a Cadet one must have two years of college "or the equivalent." That's the same as saying you don't have to know how to read a book but you must know what the words mean! By this token, then, having the equivalent of two years of college is the same as actually attending a school of higher learning. All this may sound very confusing, but it simply means that you'll have a plenty tough job becoming a Cadet if you haven't got that required college.

John Festone, Syracuse, N.Y.:—It's obvious that the Air Corps considers the P-40 superior to the P-37, because a large order was given for the former and only a token contract for the latter. As far as I know, none of the American planes you listed

have actually seen RAF service, although several have been delivered. Yes, Tony Fokker is dead; he passed away, I believe, early in 1940. Your other question would demand too much space to answer. I suggest you look up the figures at your local library.

A. Freedman, Roxbury, Mass.:—Material submitted to FLYING ACES for publication is not returned to the sender unless sufficient postage is enclosed. That is a regular policy with all magazines.

Cecil Clark, Palwa, Calif.:—The Strange stories have been dropped. We had a vote sometime ago, and it seems that the majority of readers were more in favor of modern fiction.

Charles Donald, 530 28th St., Union City, N. J.:—You say that you would like to exchange photographs of World War planes and pilots with other readers. Well, I believe that many hobbyists will be glad to get in touch with you. Also, they might be interested in those relics you wish to trade.

Charles Kimball, H. Medford, Mass.:—You can get Hamilton's *Complete Model Aircraft Manual* by mailing \$3.50 to Dodd, Mead & Co., 432 Fourth Ave., N. Y. C. Please mention FLYING ACES when writing.

Harry Jensen, Elmwood Park, Ill.:—I have no idea what it would cost to have those photostats made. Why not try one of the local companies? Sorry, but we no longer have copies of that issue available.

Corky Margiotti, Punxsutawney, Pa.:—Snapshots of the War was started when FLYING ACES was a pulp magazine. Sorry, but we have no issues available as far back as 1938.

Jimmy Ryan, Orange, Tex.:—Yes, there is a very definite rule for designating airplanes in the Army and Navy Air Services. In the Navy, XPB2Y-1 means Experimental Patrol Bomber Second Type built by Consolidated-First design. If Consolidated made minor changes on the ship, the designation would be XPB2Y-2. Then, if an entirely new patrol bomber was produced by Consolidated, the designation would be XPB3Y-1. In the Army the system is very much different. XP-38 means Experimental Pursuit-38th design, meaning that it was the 38th type pursuit selected for service. Yes, we think the Navy system is better.

THE END

With the Model Builders



Medals representing preliminary awards are shown being given to winners of the "Flight Command" model plane contest held at the Lowe's Paradise Theatre in The Bronx, N. Y. Here, Jerry DeRosa, theatre manager, and Jesse Davidson, Model Editor of FLYING ACES, and contest judge, make presentations. Left to right: Danny Feldlaufer, DeRosa, Herbert Topper, Davidson, and Walter Dambrogio.



Competitors of the "Flight Command" finals, as well as contestants from other boroughs in the greater New York area, were given a dinner in the aviation terrace at LaGuardia airport, after which three winners were selected. Left to right: Lt. Comdr. Richard Lambert, 2nd Winner Vic Codella, Lt. Comdr. Mark McChesney, 1st Winner Jeanette Eastman, Lt. Robert Power, and 3rd Winner George C. Searing.



Ten-year-old Billy Crowell, of Los Angeles, Calif., and his Super Cyclone-powered Comet Sailplane with which he won first prize in a Pasadena meet for contestants under fourteen years of age. He was awarded the FLYING ACES Trophy when his seven-foot gas craft turned in a high time of better than two minutes.



Leonard Sorby, of Brookline, Mass., holds his prize-winning Piper Cub model which took the "Flight Command" first award in the Junior Aviation League contest. The trophy is an Atom engine on a detachable mount.



There's going to be an influx of sky babies this Spring season, and from these early preview shots it looks like it's going to be a howl-



ing success, too. On the left, Martin Powell poses with his latest creation. Center photo shows Basil Giesson with his new Atom job.



And above, we have Herman Kastner who holds his box-car like fuselage, wings attached, to demonstrate streamlining is unimportant.

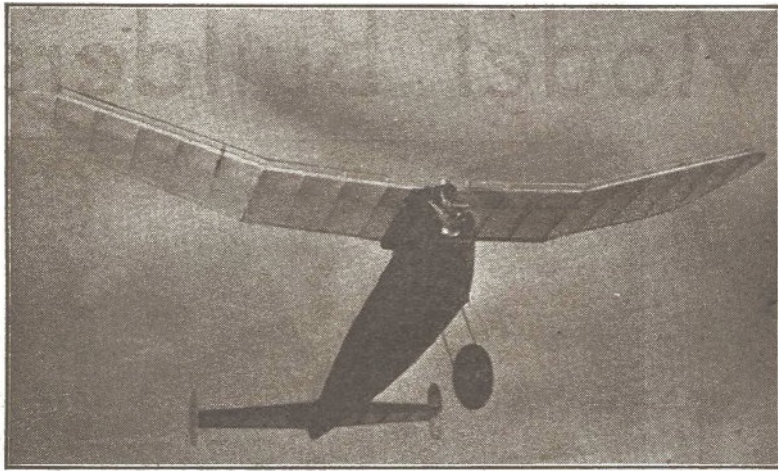

Wing slots aid in maintaining lateral stability in steepest of climbs.

Here's a trim looking craft that is good in performance, with an added feature that assures your efforts of being worthwhile.

by Robert Hayos

Drawings by Jack Greenglass

STALL-PROOF GASSY

IT WASN'T long after the end of the first World War when the England Handley Page Aeroplane Company developed a device that startled the aviation world. They had equipped one of their huge planes with an airfoil-shaped vane which ran along the leading edge of the wing and a few inches in front of it. This was the first "wing slot" ever used on a flying machine. The men who designed it realized that a device to prevent stalling was absolutely necessary, and the slot was the answer to those demands. As a plane neared the stalling speed, the angle of attack was of course increased. The wind hitting the wing at a steep angle was deflected off and the airfoil soon lost its lift.

Although the slot did not prevent this entirely, it did allow the craft to assume a higher angle of attack. The wind striking the slot and being deflected down onto the wing proper forced the plane to keep its flying speed. Because of this, a higher rate of climb could be achieved which resulted in increased performance.

When the author first realized the possibilities of wing slots being used on a model, it became evident that here, too, stalling would be impossible and the climb would be increased appreciably. Also, spiral stability would be enhanced.

Up to this point not much has been said about the ship itself. This little job was designed when the old rules were in existence, which limited the wing area to 225 square inches for Class "A" models. Since then the rules have been changed and the ship has competed against much larger models with favorable results. And although the ship has never actually been entered in competition, it has outflown many craft with much more power and wing area and has earned its salt in all types of weather. The plane has a near vertical climb and exceedingly flat glide. Under power it is extremely fast and inherent stability keeps it going smoothly

without spinning tendencies.

The combination of slots and simple design have been the secret of success of this model. The slot design explained here can be used on your own plane, provided the slots are scaled proportionally to the plane itself.

FUSELAGE AND LANDING GEAR

THE FUSELAGE is made first in the following manner. Begin by laying out the drawings on a large sheet of paper. Shelf or brown wrapping paper serves the purpose nicely. The fuselage sides are pinned to place on the plans, one side being made at a time. The longerons are of medium hard stock, while the cross braces are made of softer material having the same dimensions. Sheet balsa, $\frac{1}{8}$ " thickness is laid between the first upright and diagonal, its grain running vertically.

The wingmount is made of balsa plywood having $\frac{1}{8}$ " sheet balsa running vertically in the center and $\frac{1}{16}$ " sheet on either side running horizontally. Sand the entire mount to a streamline shape. The mount is then glued firmly to a piece of $\frac{1}{16}$ " sheet which previously has been glued across the top longerons. The tray for the wing is made of $\frac{1}{8}$ " sheet. Strips of $\frac{3}{16}$ " square are glued on either side to keep the wing from rocking. Insert a short length of $\frac{1}{16}$ " wire into both the front and rear, just under the tray and cement securely. This will enable the wing to slip off easily upon striking an object. Glue fillets are used to strengthen the mount.

The nose is of the removable type which has been found to be very convenient in the event of motor trouble. The firewall is cut from $\frac{1}{4}$ " stock and made to fit the front of the plane. The motor bearers are cut from pine measuring $\frac{1}{4}$ " by $\frac{1}{2}$ ". The cowling is of $\frac{1}{8}$ " sheet sanded to a streamlined shape. Soft balsa fillets are glued between the mounts and the cowl sides, the width being enough to accom-

modate the motor you intend using.

The landing gear is bent from $\frac{1}{16}$ " steel wire and is glued to the firewall which is notched to receive it. Sheet balsa $\frac{1}{16}$ " thick is glued over it to hold it in place. Any small air wheel may be used as long as its diameter is approximately $2\frac{1}{2}$ ". The tray is next on the production line. This is made from hard balsa and is fastened to the firewall with a piece of wire bent to the shape shown on the plans. It is finally bound to the tray with thread and then glued. Next, the tray is fastened to the firewall with a nut and bolt to keep it in place. Make the battery box in the regular manner with a piece of sheet brass at either end, with the wire connections soldered directly to it. Both the coil and condenser are bound to the tray with rubber bands wrapped tightly around the whole "works."

The nose is fastened to the fuselage with rubber that is in turn brought around two $\frac{1}{4}$ " diameter dowels, going through the fuselage and around the hook which is glued to the cowl sides.

WING AND TAIL SURFACES

ALTHOUGH OF conventional design and construction the wing must be built with care and accuracy. This is due to the fact that a slight warp on any other wing will hardly affect its flight. A warp on this wing will be disastrous, because the slots, contrary to popular belief, are not a cure all.

All ribs are cut from $\frac{1}{16}$ " sheet of medium soft stock. Trace their outlines onto the wood with the use of carbon paper. The two end ribs are slightly shorter than the rest, but are of the same outlines.

The wing spar is made from $\frac{1}{8}$ " by $\frac{1}{2}$ " hard balsa, as is the trailing edge. The latter is sanded to a triangular shape as shown on the airfoil drawing. Pin the trailing edge to the full scale drawings and begin laying the ribs in their corresponding

It's built-in safety factor plus rugged construction assure the builder of many hours of flying fun.

positions. The tips are cut from $\frac{1}{8}$ " soft sheet, glued together. The end ribs are then glued in place as is the leading edge which is shaped from $\frac{3}{16}$ " square stock. Sand the ribs so that they fit flush with the trailing edge. This will eliminate any possible wrinkles, and also improve the final appearance of the ship. The dihedral breaks are reinforced with $\frac{1}{16}$ " hard sheet balsa gussets which are glued on either side of the spar.

The slots are made from $\frac{1}{32}$ " sheet and bent to the required curve over the spout of a steam kettle. Be sure that the slots are not warped lengthwise and that the curve is consistent throughout the length of the slot. Cut the slot supporters from $\frac{1}{16}$ " sheet making them all the same size. These are laid aside for the present. The wing is covered and doped after which the slots are glued in place. At each of the slot stations shown, sand the tissue until the wood is exposed. Then carefully cement the slot supporters in place, allowing them to dry thoroughly before attempting to glue the slot on. The slot itself is made in four sections, a new length being cut from the present wood. Glue the sections to the supporters using small pins to hold them in position until dry.

The tail is made next and is of the twin fin-type. The stabilizer is not actually a lifting surface but will aid in maintaining the type of glide that is accompanied by the use of such an empennage.

The stab is made from $\frac{1}{4}$ " by $\frac{1}{8}$ " strips except for the leading edge which is of $\frac{3}{16}$ " square and also the $\frac{1}{32}$ " sheet with which the indicated sections are covered. Make the rudders from $\frac{1}{8}$ " sheet, the grain running vertically (to prevent splitting in "hot landings") and then sand to the form shown on the top view.

The elevator ribs are $\frac{1}{4}$ " by $\frac{1}{8}$ " laid on end. The ribs taper downward from the spar back. Sandpaper all these parts smooth before attempting to cover with balsa. Pins are used to

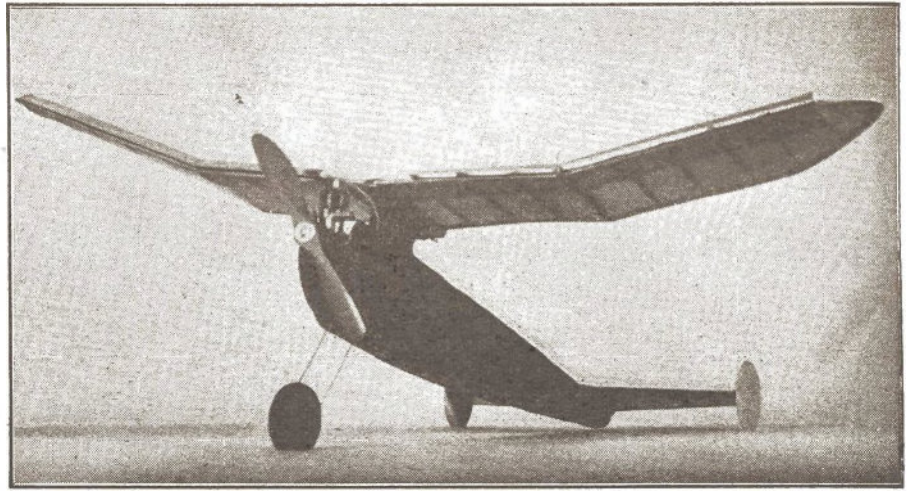

hold the sheet in place until the glue dries. Leave about $\frac{1}{8}$ " overlap of wood which when sanded will fit smoothly into the stab proper. The rudders are then glued flush against the end ribs. A small piece of wire may be bent to fit the curves of the bottom of the rudders to act as tail skids.

COVERING AND ASSEMBLY
WHEN THE framework has been completed, sand everything with a fine grade of paper so that all the fuzz is removed. Use plain clear gas model dope for adhesive in applying the tissue.

The fuselage is covered first, the grain of the paper running horizontally. Leave a $\frac{1}{8}$ " border on all edges to overlap, so that no wood is exposed. The wing is covered in four sections, a new piece being used at each break for the dihedral. Both the stabilizer and wing are covered with the grain running spanwise. The balsa rudders are also covered with tissue, the grain this time going vertically—in the same direction as the grain in the wood.

The front of the nose may also be covered, either with $\frac{1}{32}$ " sheet or with tissue, and then highly doped. This is not recommended as the dripping gas and oil offer a fire hazard. Not much difference will be noted in the performance whether

this section is covered or not. However, if you are willing to risk a slightly charred motor, you may find that your ship will float just a few more feet before landing.

The wing mount is also covered with tissue, the wood being first doped. Do not attempt to cover the whole mount in one section, but rather use small pieces. Use any kind of colored paper you wish for covering the entire of the model.

ADJUSTMENTS AND FLYING
FEW ADJUSTMENTS will be needed. The original model powered with an Atom, has $\frac{3}{16}$ " incidence under the leading edge of the wing. A later model powered with a Bantam required a piece of $\frac{1}{8}$ " square under the trailing edge of the stab, in addition to the $\frac{3}{16}$ " under the wing.

On the first flight not more than twenty-five per cent of your power should be used, if you are using a $\frac{1}{7}$ horsepower motor. The engine should in no event be leaned down on the preliminary flights, as a dying motor is fatal, after the first few seconds of the takeoff. More power can be tried slowly until you have full confidence.

The rest of the adjustments are left to the discretion of the builder, so that we will not be held responsible if you should lose your model on her first thermal.

BILL OF MATERIALS

- 14 pieces $\frac{3}{16}$ " sq. by 36" for long-erons, etc.
- 8 pieces $\frac{1}{4}$ " by $\frac{1}{8}$ " by 36" for tail parts
- 4 pieces $\frac{1}{16}$ " by 2" by 36" for ribs
- 2 pieces $\frac{1}{8}$ " by $\frac{1}{2}$ " by 36" for cowl etc.
- 2 sheets $\frac{1}{8}$ " by 3" by 36" for rudders
- 2 feet $\frac{1}{16}$ " steel wire-landing gear
- 1 piece $\frac{1}{4}$ " by $\frac{1}{2}$ " pine for motor mounts
- 1 piece $\frac{1}{4}$ " by 3" by 4" for firewall
- $\frac{1}{2}$ pint clear dope
- $\frac{1}{2}$ pint gas model glue
- Tissue, colored dope, pins, nuts, bolts, and drawing paper.

THE END

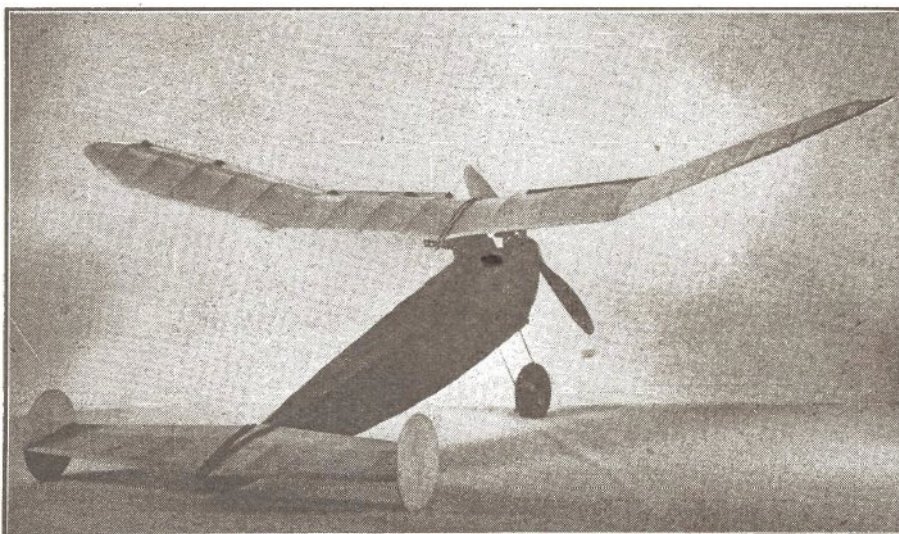

Twin-finned tail surfaces and polyhedral wings contribute to consistently good performance.

A STALL-PROOF FLYER—Plate 1

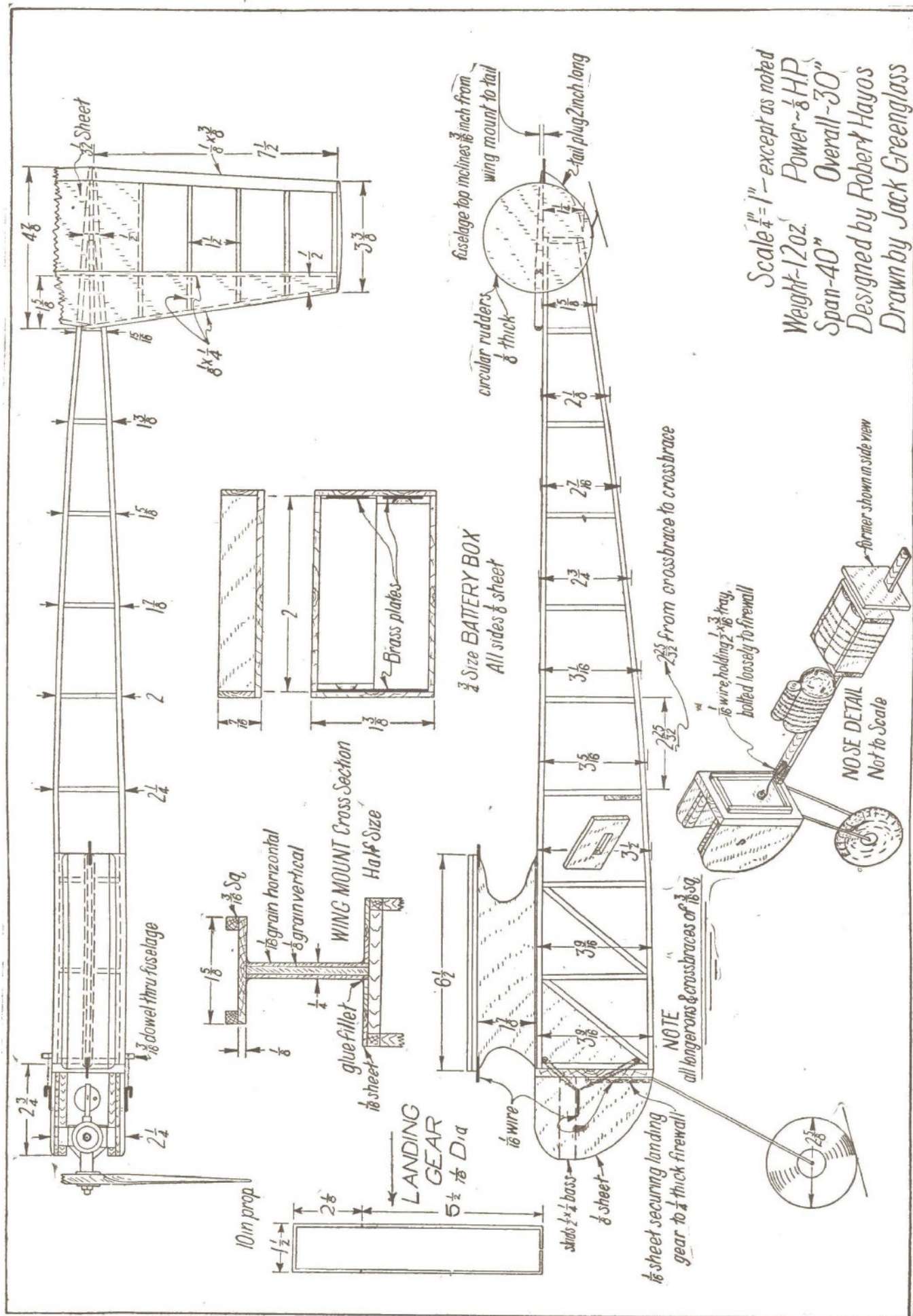

A STALL-PROOF FLYER—Plate 2

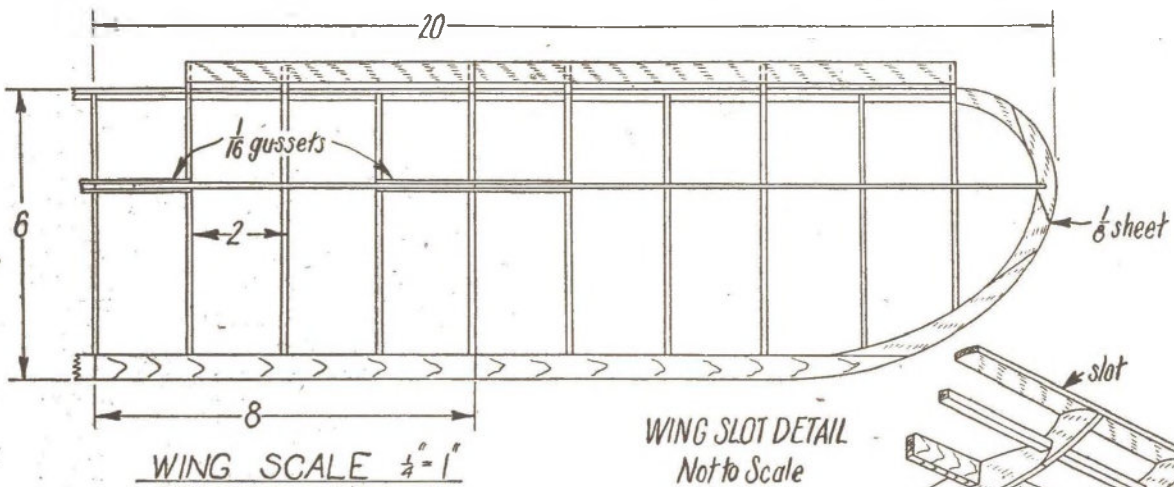

WING SLOT DETAIL
Not to Scale

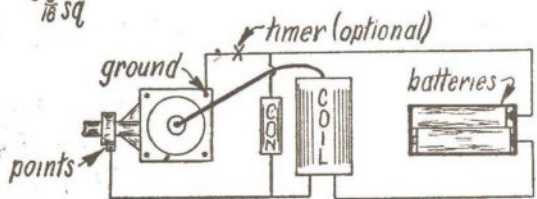
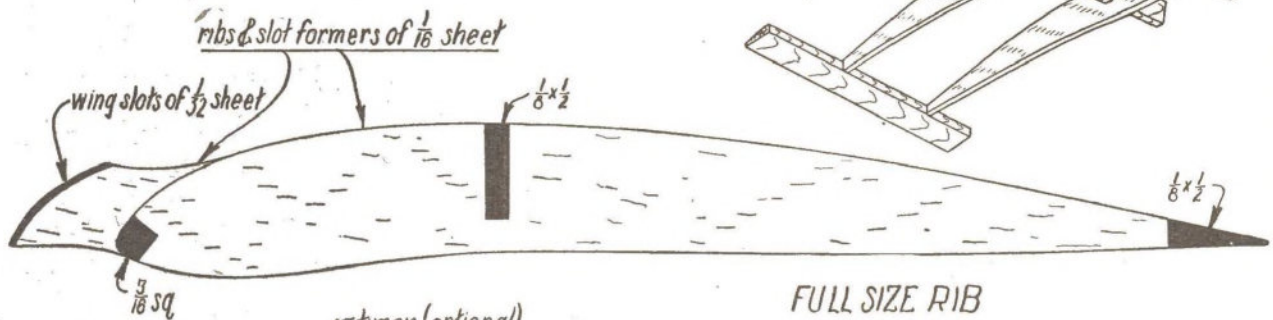
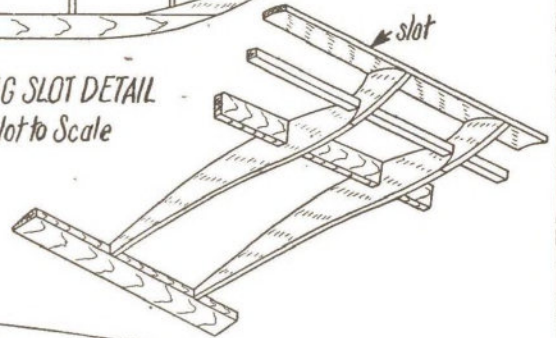

Bend to shape

Make 12

IGNITION SYSTEM

SLOT SUPPORTER

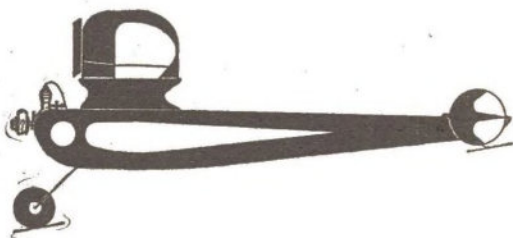

ASSEMBLY DRAWING
Scale $\frac{1}{12}''=1''$

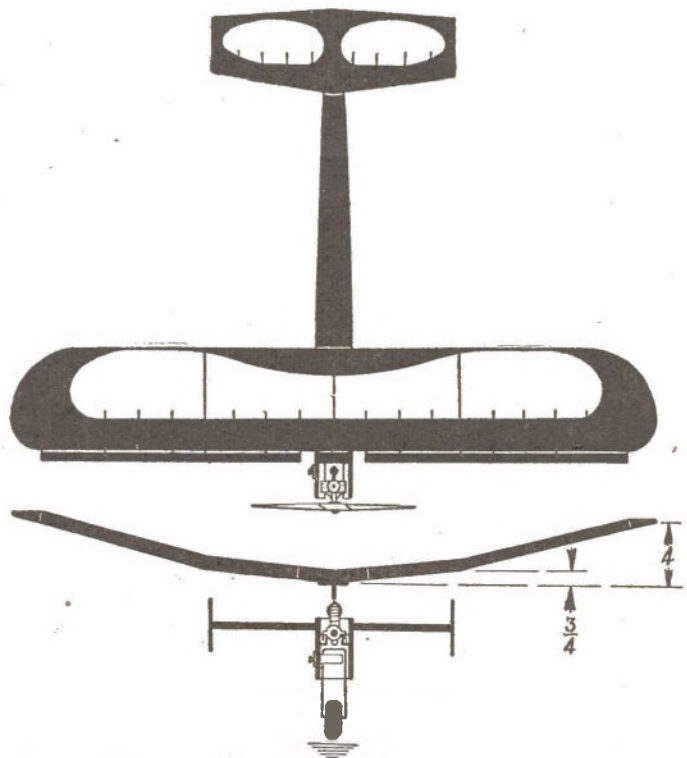

It's The Finish That Counts

All that glitters is not gold, true. But many things in life are still judged by their surface.

BY FRANCES SAVARESE

WHETHER IT BE a beautiful horse, dog, or race car, there's no telling before a race which is the sure winner. As contenders, all stand a fair chance. But in the end, it's the finish that counts. And so it is with a model plane. In an exhibition meet, you'll find many beautifully constructed ships, detailed so faithfully you remark in astonishment. But how about that paint job, the cover upper, the healer of all blemishes? Yes, in a beautifully built job or even a crummy one, the covering, doping, and finishing is the first thing that catches the eye.

Many modelers admit, much to their regret, that while they are able to turn out a decent construction job, they fall down on the final completion. There's no reason for this. A fine finish on that new ship may be yours if you'll try the method I have used very successfully.

Assuming that the model has been correctly covered, select a room having a moderate temperature (about 70 degrees fahrenheit) to start the doping procedure. Don't work on a rainy day or use a room in which the air is constantly circulating. These elements tend to make the dope bluish. Even a humid day causes blushing. In other words, don't be in a hurry to dope the ship until the weather is just right.

SELECTING THE MATERIALS

USE A FINE grade of dope, both pigmented and clear. The choice of brushes should be carefully selected as this makes a lot of difference in the final job. They should be of a good quality of camel or ox hair. A coarse cheap brush will produce streaks caused by hard bristles or loose hairs. This naturally tends to spoil the finish in two ways. First, the loose hairs may not be detected immediately and will dry into the

dope. Second, in trying to remove them while the dope is tacky, some of the dope will rub off causing thin spots here and there.

SOLID SCALE MODELS

THESE MODELS should be sanded as smooth as possible with a very fine grade of sand paper. Between two and four coats of wood filler should be applied a full fifteen minutes apart. After the parts have been given their last coat allow same to dry for six or seven hours, or better



The author and his ship which took first prize in the Wonder Bread Model Plane Contest, New York World's Fair of 1940.

still, over night. After these first steps the parts should be sanded to a gloss like surface with number 7/0 sand paper. A good thing to keep in mind is to dope and sand in one direction, the sanding to be done *very* lightly. Wipe off the sand dust and start to apply the color. Four or five coats, properly thinned out according to the manufacturer's direction, is sufficient.

The dope should be applied in heavy wet coats one hour apart. Prior

to last coat the parts are sanded with 7/0 sand paper again and when ready for the final coat, the dope should be thinned out up to 75%. This takes out any brush marks and gives a glossy appearance. All parts should be finished off separately and then assembled.

RUBBER POWERED CRAFT

IN THESE flying models weight before good looks should be our main concern. Colored tissue should be used and is a great factor in the saving of weight. Between two and four coats of dope, depending on the size of the model, should be sufficient. These coats should be brushed on fifteen to twenty minutes apart. Each coat should be sanded over lightly to insure a clear surface. All exposed wood parts should be given several applications of wood filler. *Never* sand over the ribs.

GAS MODELS

DO NOT use less than three coats of dope on the model as the oil thrown off by the motor tends to make the covering soggy. After the model has been properly doped a good thing to do is to apply a coat of either clear lacquer or liquid celluloid. This gives a very hard, smooth and glossy finish.

There is another method in finishing models and that is the use of pigmented dope. Between three and six coats of dope are used, sanding between each coat with 7/0 sand paper. Allow each application to dry for one hour. After an overnight interval rubbing compound may be applied to the surfaces and rubbed with a soft cloth. Care should be used so that you don't rub hard over ribs or corners thereby cutting into the tissue or silk. After this, brush or spray a coat of pigmented dope over the entire surface. The last coat should be thinned
(Continued on page 80)

A perfect covering is most important before applying dope.

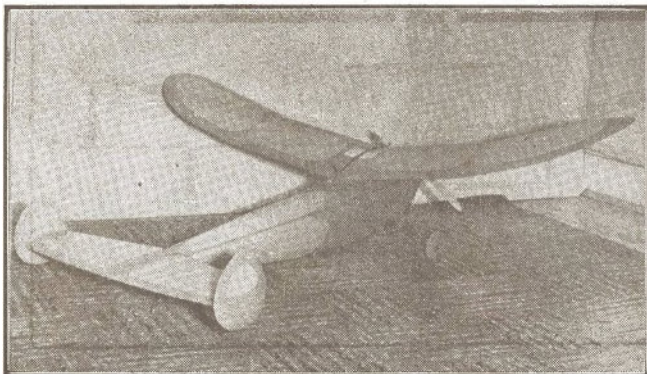

Minimum external parts reduce the possibility of wrinkles.

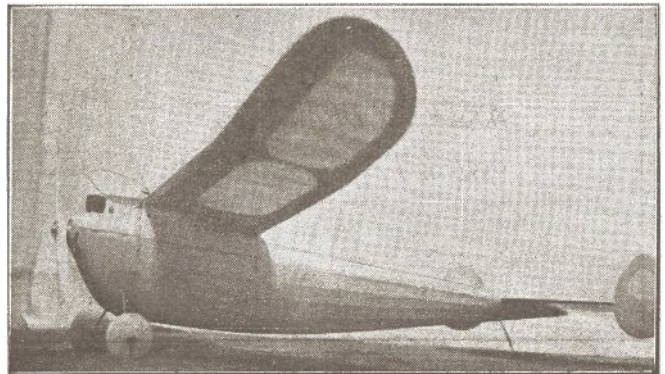
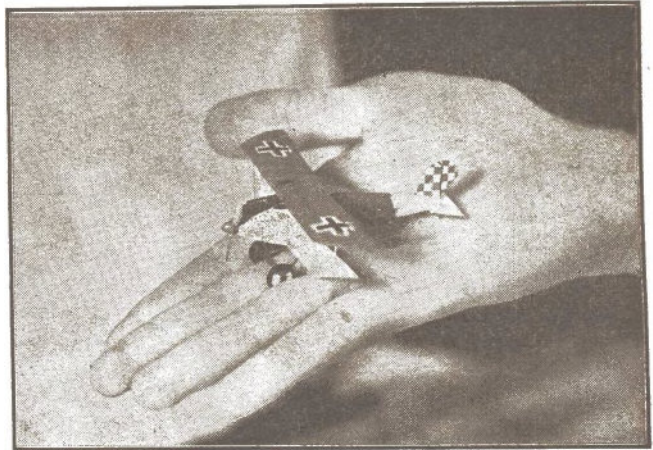

TABLE TOP Aerodrome

Allan F. Kitchel's unique collection of miniature war planes is one for the Believe It Or Not fans.

by Harry Losin



When the proud owner of this unusual collection tries to "palm" one off on you, he certainly does a good job of it.

TO MOST PEOPLE the first World War is ancient history, but to Allan F. Kitchel, Jr., that big scrap is kept alive with vivid flashes of gayly colored sub-miniature planes diving and zooming in typical dogfight fashion.

Kitchel, you see, is designer, builder, and commanding officer of the world's smallest aerodrome. Every ship is in tip-top shape, lined up for action—but never gets to see any of it. "Kitchel Field" is located in an apartment house in a fashionable section of New York City. The table top aerodrome is complete with a huge hangar, portable repair station, and supply depot. It's been under construction for almost ten years now.

Let's go back a decade ago and find out how all this started: Young Alan was an aero enthusiast at the time aviation was booming. However, his interest seemed relegated to the past for the dashing-colored war planes on the covers of a model magazine always fascinated him. The more he cut them out and filled his scrap book, the more he wished he could build them—in miniature. So one day he hauled out his trusty Boy Scout knife and

whittled while he worked. If plans for the little ships weren't to be found, Kitchel, an artist in his own right, would make accurate working drawings from pictures and paintings.

He uses balsa wood for the body, wings, and tail. A common house pin

and silk thread plus an enormous amount of patience is used to place the landing and flying wires into position.

The amount of detail he gets into these dwarf-like miniatures is amazing. And he's a stickler for detail, too. Working time per ship averages

about two weeks spare time, although when he finds a whole day to labor he can turn out a job in eight to ten hours. The work is rather trying on his eyes and disposition, but that is the fate that befalls all craftsmen working on minute objects. What does take a lot of time is putting in the little tail surface controls. Kitchel uses a special kind of quick-drying lacquer which helps to cut down the working hours. Three or four coats are usually applied to each model.

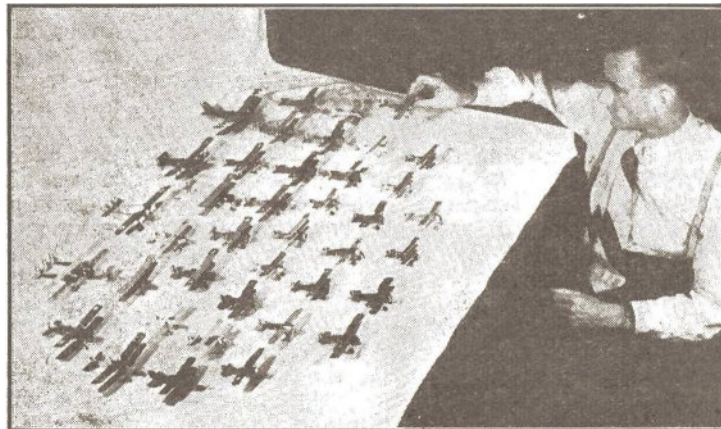

Kitchel poses with part of his collection of miniature planes. His favorites are ships belonging to the leading aces such as the Sopwith Camel of Canada's Bishop, the Spad of Rickenbacker, the Fokker Tripe of Richthofen, and the Nieuport of Guynemer. They're in front.

is used for an interplane strut to which is cemented a slither of sheet balsa to form the streamline fairing. To hollow out a cockpit, he takes a proper sized nail head, heats it over the gas flame, and presses it into the right spot on the fuselage—which does the trick very nicely. Needle

KITCHEL'S MOST important item for his miniatures are the wheels. If you can mentally picture a three- and a half-inch craft. The landing wheels would be quite small, wouldn't they?

Somehow, a long time ago, Al got a tip that the manufacturer of certain miniature toys was about to cur-
(Continued on page 68)

The little Fokker D-7 is almost a match for comparison.



Rule-of-thumb method is often used. The Spad is typical.

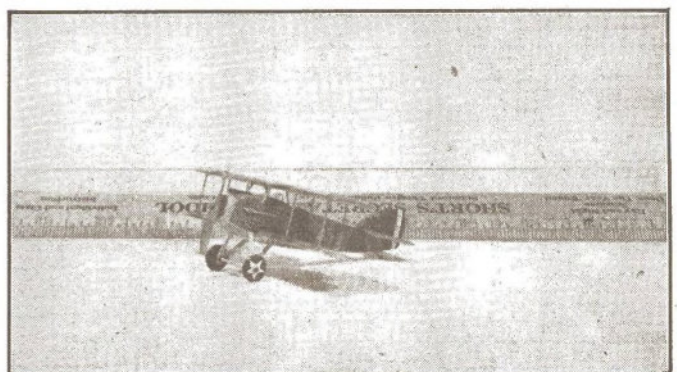

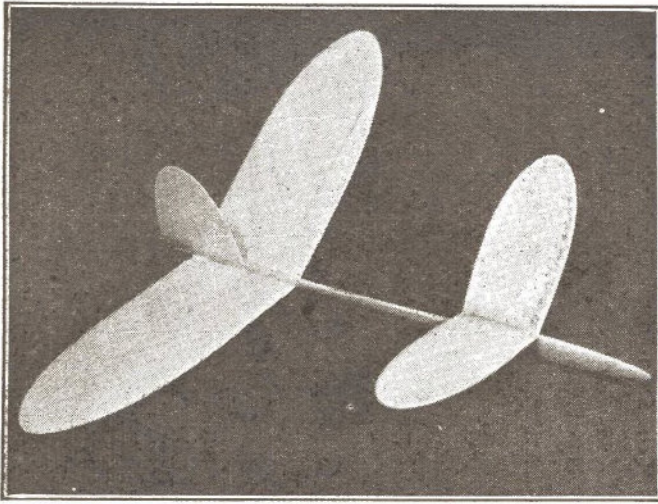

Sleek lines, elliptical wing and tail give it grace of flight.

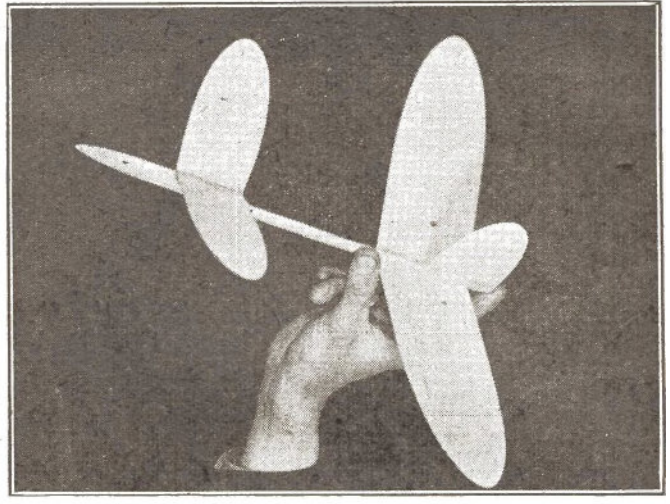

The method in which our glider is held for outdoor launching.

OUTDOOR PUSHER GLIDER

Hand Launch builders will find this excellent performing craft fun, educational, and instructive.

PUSHER GLIDERS, although not as popular as tractor types, are nevertheless exceptionally good performers. The following instructions and accompanying plans, it is hoped, will go towards making this type glider more popular. But we'll let the facts—or rather, the performances—stand by themselves. Good outdoor weather will certainly make the opportunity possible.

CARVING THE FUSELAGE

THE PLAN is exactly half scale. Measurements may be taken from it accurately by using a scale rule or a pair of dividers. Draftsman curves will also be useful in obtaining the correct outlines for the elliptically shaped wings and tail surfaces.

Make a full-size drawing of the fuselage on a piece of stiff paper or flexible cardboard. Trim this with a pair of scissors and proceed to trace its outlines onto a piece of hard balsa measuring $\frac{1}{4}$ " by $\frac{3}{4}$ " by $12\frac{7}{8}$ ". This piece should be hard throughout and perfectly free of knots. A sharp knife is used to obtain the final shape. Next, use coarse sandpaper to trim down to the line limits. The cross-section shown in the front view is consistent throughout the length of the body. In effect, it is egg shaped. This sectional outline may be obtained by using sandpaper only. Finish the stick off with a very fine sanding.

WING AND TAIL

USE STIFF paper templates for the wing and tail parts. For the wing one template is necessary for both panels, as is for that matter for the elevator. Cut to the proper size and width, the template is laid flat upon a piece of sheet balsa measuring $3\frac{3}{32}$ " by 3" by $7\frac{1}{2}$ ", and its outlines faithfully traced. The shape of

the elevator and rudder are also traced on a piece of sheet balsa, measurements of which are given above.

A balsa cutting knife is ideal for trimming the parts. Cut as close to the lines as possible and sand down the rest to its true outlines later. Take the wing first and proceed to sand it to shape so that the camber or airfoil section is faithfully reproduced as shown by the solid black form on the plan. Getting the correct airfoil section is very important, for therein lies the quality that goes to make an excellent performing craft.

Taper the wing tips down to a fine degree so that when they are held up against a light at least a quarter of an inch margin around the tips allow the light to come through.

The elevator is made in one piece and is sanded to shape so that its airfoil section conforms to that shown in the plans. Note the slight under-camber and the sharply pointed leading edge. The rudder is simply cut to shape and streamlined as shown by its top-view outline on the fuselage stick.

ASSEMBLY AND FLYING

TO ASSEMBLE the parts, first stand the body on edge perfectly. Then hammer on each side two fair-sized pins so close to the stick that the stick remains upright. The best place to install these pins is about one inch back of the nose and at any point between the elevator and wing. While the body is in this rigid jig, you may apply cement to the portion of the stick where the elevator will be attached. This portion measured

direct from the plans should be marked off and that part sanded so that the place is slightly flat, allowing more gluing area for the elevators. Apply cement to the position and then additional cement to the center halves of the elevators. Press the parts in place and insert small model making pins so that while the parts are drying, the dihedral angle may be set at the same time. Use small "prop" blocks under the extreme ends of each wing tip to get the required angle. Apply additional cement along the center of the crack.

The wing panels are cemented to each side of the body at the rear end as shown in the side view. This part should have been previously marked off. Apply cement to each side of the body and the wings and attach one panel at the time. Insert model making pins to hold the required dihedral angle in position. Next, add the remaining wing panel. Again use small blocks at the wing tips to hold the angle until the cement hardens sufficiently to allow their removal.

Cement the rudder in position as shown. Later, it can be warped slightly to the left as required. The shaded areas around the wing and tail parts indicate the position where the greatest strain is imposed and therefore additional cement should be applied around those regions. This should be done on the underside as well.

When the ship is complete it is then ready to receive coats of dope.

The author's Pusher Glider performed best when circling to the left and seemed to reach higher altitudes in tight turns. On the way down, however, it would sail straight ahead. The best time yet accomplished with this ship has been well over five minutes. Its average time, however, fluctuates between 45 and 50 seconds.

THE END

by *Edward Shane*

FLY THIS OUTDOOR PUSHER GLIDER

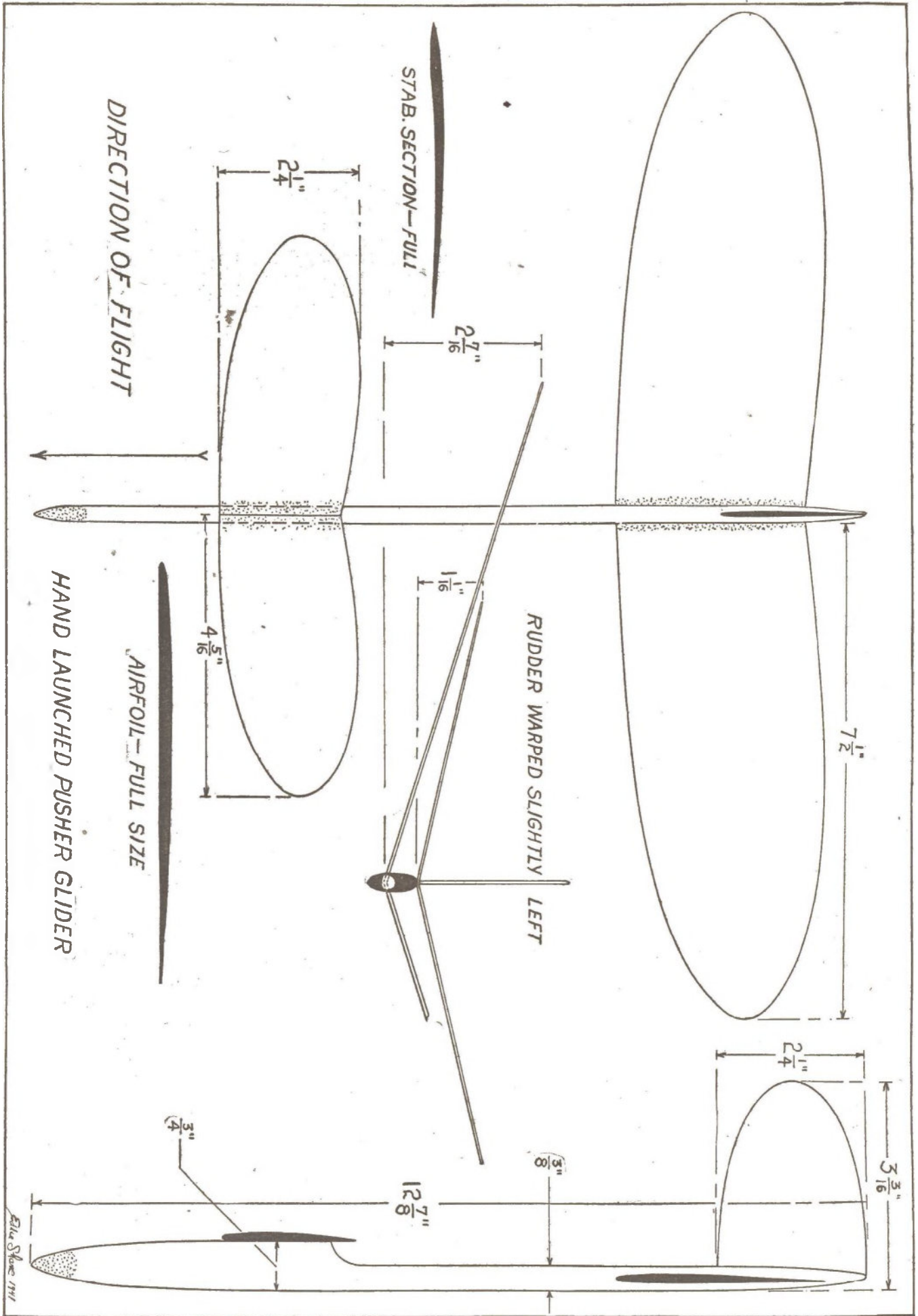

News of the Modelers

All model clubs are urged to send us reports of activities for inclusion in this department—advance dope on contests, club activities, and results of meets. Such news should be sent to us as promptly as possible, and advance notice of contests should be in our hands at least six weeks before the tourney. Address letters to Model Editor, FLYING ACES, 67 West 44th St., New York City.

Nationals to Chicago

The 1941 National Model Airplane Championship Meet will be held in Chicago the first week in July under the sponsorship of the Chicago Times and the Chicago Park District, it was announced by AMA Headquarters.

The Fourteenth Annual Competition, designated by the AMA as the leading model meet of the year, is expected to draw more than 1,200 contestants and 100,000 spectators. The various indoor and outdoor events will be held on July 2, 3, 4, and 5, with contestants' registration on July 1 and a victory dinner at the official headquarters hotel, The Sherman, on Saturday evening, July 5, to climax the meet.

Entire floors of the Hotel Sherman are expected to be turned over to the entrants who will come to Chicago from every state. A huge workshop will be set up where modelers can build and repair their miniature flying craft at any hour of the day or night. Transportation facilities will be provided for contestants between The Sherman and the model outdoor airport at 79th Street and Keeler Avenue in outer Chicago and the indoor flying arena, the International Amphitheatre.

Camping facilities will be made

available to those who desire to "rough it" while attending the meets. Theatre parties and free admission to Chicago amusement parks are planned. A "beauty contest" for the best finished model craft will be held in The Sherman and will be open to all type of entries. The public will be invited to participate in judging the entries by balloting for favorites.

A model aircraft industry show is expected to be the highlight of the annual event as will be the yearly meeting of the AMA. This session is expected to be a short one since the various committees of the Academy, including the Contest Board, Research, Resolution and Nominating groups, will assemble evenings during the model meet to listen to suggestions from the model flyers concerning official model plane regulations, AMA activities and candidates for the various offices of the Academy, the governing body for model aviation in America.

A unique program of events describing the various types of models flown and giving an insight into the aeromodeling activity is contemplated by the committee on arrangements. This program will be presented without charge to each contestant registering as well as to the

many thousands of spectators who will turn out to see each day's flying.

From the competition end, timing and "processing" equipment and methods perfected by the Chicago Park District will speed up this work as never before. Model plane leaders in the Park District under the supervision of Crafts Supervisor F. E. Kardes, have been devising new ways and means of measuring models which must conform to AMA standards as well as recording and computing flight durations of various types of model aircraft.

This work has been going on since last July when Park District officials held a session immediately following the 1940 "Nationals" in an effort to better their contest procedure.

South American Way

Latin American countries are studying model airplane activities of the youth of the United States, with the intention of inaugurating similar activities in their own countries, according to the report by Ernest Gamache, executive director of Air Youth. Brazil has shown considerable interest and a number of groups are already using the Air Youth program in Puerto Rico.

As a gesture of good will to the youth of South America, information concerning the activities that have made American boys world record holders in building and flying model planes is being sent via the Civil Air Mission headed by General Frank R. McCoy, who is now on a South American tour under the sponsorship of the Inter-American Escadrille. Visiting the capitals and principal cities of all the South American countries, members of the Air Mission will inform educators and leaders of youth groups of the youth aviation program which is being developed in this country by Air Youth of America. Although soaring and gliding has been actively taken up in some South American countries, there has been little activity in model planes, Gamache pointed out.

AYA Goes Hollywood

Air Youth of America makes its initial bow in a Hollywood produced motion picture which is shortly to be released by Universal Pictures. Titled "Skyraiders" the movie is a serial designed to meet the demand for action and excitement of the youthful Saturday audiences in the neighborhood theatre. Youthful star of the picture is Billy Halop, who first won fame as a member of the Dead End Kids. Billy plays the part

CONTEST CALENDAR

Clubs and organizations sponsoring model airplane meets are urged to send us advance notification of contests for inclusion in this calendar. Such notices should be in our hands at least six weeks in advance of the tourney. Results of meets, and pictures when possible, are likewise desired for inclusion in our model news columns. Address Editor, Model Department, FLYING ACES, 67 West 44 Street, New York City.

NAA SANCTIONED MEETS

Sacramento, Calif.—April 27; Second Annual Superior California NAA Powered Meet to be held at Mather Field. Perpetual trophy and cash prizes. Write Theodore L. Ravellette, 3124 Fourth Ave., Sacramento, for information and entry blanks.
Philadelphia, Pa.—May 3; Third Outdoor Endurance Meet. Class "A". Philadelphia Model Airplane Association. Contact Victor R. Fritz, 1427 Spruce St.
Boston, Mass.—May 3; Jordan-Traveler Class "A" indoor meet. Gunnar Munick, director, 101 Alstead St., Quincy.
Albany, N. Y.—May 18; Schenectady Aeroneers sponsored meet; open to stick, cabin, sail-plane, and gas jobs. Big prize list. All dope from J. P. Lusk, director, 204 Clinton St., Schenectady.
Pittsburgh, Pa.—May 19; Third Allegheny Mountain Area Model Meet; Class "AA." Write Harry Vogler, 1633 Duffield St.
Philadelphia, Pa.—May 31; Indoor Championships Class "A." Philadelphia Model Airplane Association. See address above.
Boston, Mass.—May 31; Class "A" beginners competition. Write Gunnar Munick at above address.
Geneva, N. Y.—June 1; Record trials for ROW gas jobs for all classes. Write Luke Boughter, Sr., 43 Maple.
Philadelphia, Pa.—June 7; P M A A Outdoor Championship. Contact Victor Fritz. See address above.
Albany, N. Y.—June 8; Fifth Annual State Exchange Model Airplane Invitation Meet to be held at the municipal airport. For entry blanks write after May 1st to Harry Copeland, 712 Loew Building, Syracuse.
Atlanta, Ga.—June 14-15; Southeastern meet for gas and rubber models. Contact H. R. Hudson, 732 Techwood Drive.
Marshalltown, Iowa—June 15; Sixth Annual Tallcorn State Model Airplane meet. Six big events. All information from Wallace R. Blake, Director, 18 North First St.
Atlanta, Ga.—June 21; Atlanta Aero Engineers night flying contest. See address above.
Pittsburgh, Pa.—June 22; Pittsburgh Allegheny Mountain Area seaplane meet. Class "AA." Contact Harry Vogler at above address.
Chicago, Ill.—July 2 to 5; 14th Annual National Championship Meet.

of Tim Bryan, portrayed as an expert model builder, and a member of Air Youth of America. Each of the early episodes of the serial features sequences dealing with model planes, and in one there is shown a few shots from a contest held in Denver.

Air Youth is making arrangements in cooperation with Universal to assist theatres that wish to sponsor model plane exhibitions and contests with the showing of the picture.

Model Aviation—A Career

Careers in Model Aviation—How To Make Your Hobby Pay You, is the title of a book just published by Winston Publishers, of Brooklyn, N. Y. This book, written by the staff of one of the largest model concerns in the country, is the first edition of its kind that points out how the model enthusiast can turn his skill and ideas into money, by making his hobby his lifetime work.

Every angle of the model industry, and the hobbyist's relation to it, is covered. The hobbyist reading this book can determine just in what phase of the industry his talents are most applicable, how he can get a full or part time job, how to develop his talents and where to sell his ideas. The book covers drafting, selling, jobbing, manufacturing, and all phases of the model airplane and miniature gasoline engine industry.

Snowbird Contest

The Brooklyn Skyscrapers models airplane club "snowbird" meet attracted seventy-five contestants from Yonkers, Poughkeepsie, Hartford, Philadelphia, and New Haven, as well as from the metropolitan area.

Carroll Moon, club director, and Sal Taibi, chief timer, officiated at the free-for-all Open Class meet. Winners were awarded engines, model kits, and supplies.

Results: First, Jerry Broffman, Brooklyn, N. Y., 3 min., 2 sec.; second, Cliff Travers, Yonkers, N. Y., 2 min., 2 sec.; third, John Kebba, Queens Village, N. Y., 1 min., 56 sec.

On Borrowed Time

GHQ Motors, of 40 East 21st Street, N.Y.C., wishes to call the attention of high school and technical school instructors that it has available a limited number of factory assembled GHQ gas engines which may be borrowed for thirty days upon payment of postage both ways. Instructors should address letters to GHQ on their school letterhead for application blank. Motors will be loaned in order of applications received.

Model Defense Workers

Skill developed by model airplane hobbyists is proving of practical service to the national defense, it was recently reported by the AMA.

More than two hundred of these young men are working at Langley Field laboratories of the National Advisory Committee for Aeronautics. Entered under Civil Service exam-

NOTES

FROM THE WORKBENCH BY RAY WEEKS





WING RIBS



SILK THREAD DOPED ON WING BEFORE PAINTING GIVES REALISTIC RIB EFFECT.

SOLID SCALE MODELS

SMALL CAPSULES

CAN BE USED FOR NAVIGATION LIGHTS, PROP HUB TIPS, ETC.



SMALL PROPS

SMALL WIRE TUBING FLATTENED AND FILED TO SHAPE OF BLADE.

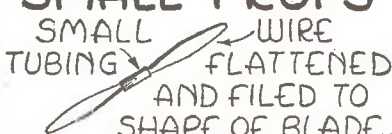

METAL FINISHES

METAL FOIL FROM CANDY BARS ETC., WHEN CAREFULLY SMOOTHED OUT CAN BE CEMENTED OVER FUSELAGES ETC. APPLY IN SECTIONS WORKING FROM REAR TO FRONT. CAREFULLY FIT EACH PART—APPLY WITH RUBBER CEMENT. EXCESS CEMENT RUBS OFF EASILY WHEN DRY.

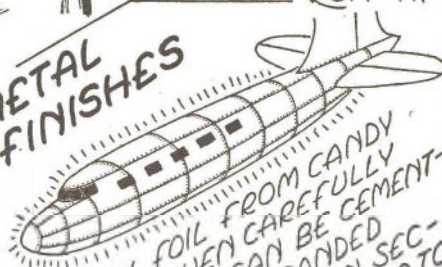

DIHEDRAL

CEMENT ALL JOINTS



1. SAW CUTS
2. THIN WOOD
3. TRIM AND SAND

SMALL CYLINDERS

WRAP SMALL DOWEL WITH THREAD—DOPED CUT DESIRED LENGTH



inations, they are classified as Model Aircraft Makers but are performing a wide variety of duties. They not only build but test the scale models at Langley. One group is building a propeller for the new high speed wind tunnel. They are found superior to skilled craftsmen because they know the theory of flight and the practical details of plane construction.

Charles A. Hulcher, the first model builder to be employed by the NACA, now is supervising the work of fifty young men from eighteen to twenty-

to 18-year-old Stanley Dubrowski for his Vought SBU-1, which was built to a five-eighth inch scale.

Elm Bugs Elect

Installation of new officers of the Elm City Gas Bugs Model Airplane Club took place the latter part of February at the New Haven Municipal Airport. The following were elected to office: President, William Paulson; vice-president, Melvyn L. Agne; secretary, Helen Paulson; treasurer, Walter Kavolski; publicity, Jules V. Agne.

"Ham" Radio License Required

The Federal Communications Commission requires that operators of broadcasting equipment transmitting radio impulses for communication or remote control hold proper license. Modelers who contemplate experimenting with radio control craft should write to the American Radio Relay League, 38 La Salle Rd., West Hartford, Conn., for information.

THE END

Military Models Popular

Out of the eighty-six entries in the fourth annual solid scale model contest held recently by the Stix, Baer, and Fuller Model Airplane Club, of St. Louis, Mo., military ships far outnumbered the commercial types. This, it was decided, was due to the impetus given to military aviation and the great variety of fighting jobs which are adaptable to scale model purposes.

First prize in the senior class went

Ignition— AND HOW IT WORKS

Gas model construction at its best isn't worth the effort — unless that "spark" is there!

BY THRACY PETRIDES

IN ORDER for a thing to burn, it must be provided with oxygen. Oxygen is found in air, therefore it is usual to say that air is necessary for combustion.

Gasoline vapor mixed with air forms the explosive mixture used in the gas engine; this mixture must be ignited at exactly the right time to have a perfectly-functioning engine. If ignition occurs too soon or too late there is a loss of power.

The greatest power is obtained when the gas mixture is burning; this should take place just as the piston begins to move downward on the power stroke. A short time is required for the mixture to burn, as there is a brief interval between the moment it is set afire and the time it is completely aflame. Thus, if the mixture is to be burning as the piston starts its power stroke it must be set on fire before that time—or, in other words, toward the end of the compression stroke.

The point of firing depends on the speed of the engine. When ignition occurs early in the compression stroke, the engine is advanced; when it is late, it is retarded. The engine produces maximum power with the ignition advanced as far as possible without causing knocking or pre-ignition.

The gasoline mixture is set fire by an electric spark, and the parts

that produce and control this spark are called the ignition system.

The hook-up consists of: a spark coil, a timer, a spark plug, a switch, and wires by which the parts are connected.

THE ELECTRIC current that produces spark for the model engine is created by magnetism. In the coil, magnetism is obtained by the flow of electricity through turns of wire wound around an iron core. Iron is a magnetically permeable metal while copper is non magnetic—that is, magnetic currents can flow through the latter but it cannot be permanently magnetized. An example will clarify this. If a pile of iron filings is stirred with a copper wire, there will be no effect. However, if the wire is attached to the terminals of a live battery, iron filings will cling to it as if it were a real magnet.

It is one of Faraday's basic principles of electricity which states that when an electric current flows through a wire the wire is surrounded by a magnetic field which continues to exist as long as the current flows. And conversely, an electric cur-

rent is produced when a wire is held in a magnetic field.

The coil and condenser system used in model gas engines utilizes this principle. It is known as induction, and the forces produced are known as induced currents.

The system employed, shown in Fig. "A," is a coil of wire wound around one end of an iron core and connected to a battery. Fig. "B" shows an entirely separate coil wound around the other end of the iron core, with the wire ends separated by a short distance. By closing the breaker, which puts the batteries in circuit, the current will flow into coil "A" and the iron core will be magnetized. The magnetic field that is created will be felt by coil "B" and an electric current will flow through that coil. When the breaker is opened the current stops flowing and the magnetism dies. In other words, the magnetic intensity of the core has changed from maximum to zero. These changes in strength create an intense electric current in coil "B" which will form a spark.

When the change of magnetic field strength is very great—that is, when the magnetism changes from very weak to very strong or vice versa, the electric current in coil "B" is more powerful than when there is only a small change in strength. And, in addition, a greater current is also produced by a change that takes place suddenly than by a change that takes place slowly.

IN MODEL ignition coils, as in "B," the secondary is wound on top of "A," the primary. The primary winding consists of a few layers of coarse wire around an iron core. The secondary winding is a great number of turns of fine wire wound closely to the core.

To obtain the necessary current intensity to jump the spark plug, which is under high pressure when ignition takes place, battery current flows through the primary winding to create magnetism and is then stopped by the breaker opening. This, in turn,

(Continued on page 67)

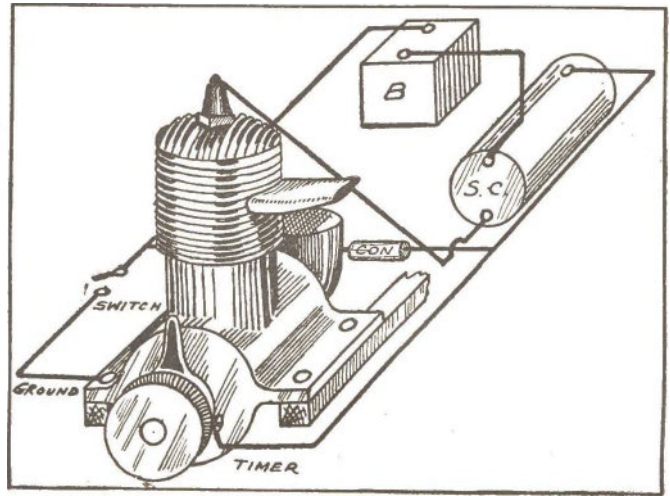

This perspective drawing illustrates the correct method of hooking up the ignition system to your gas motor.

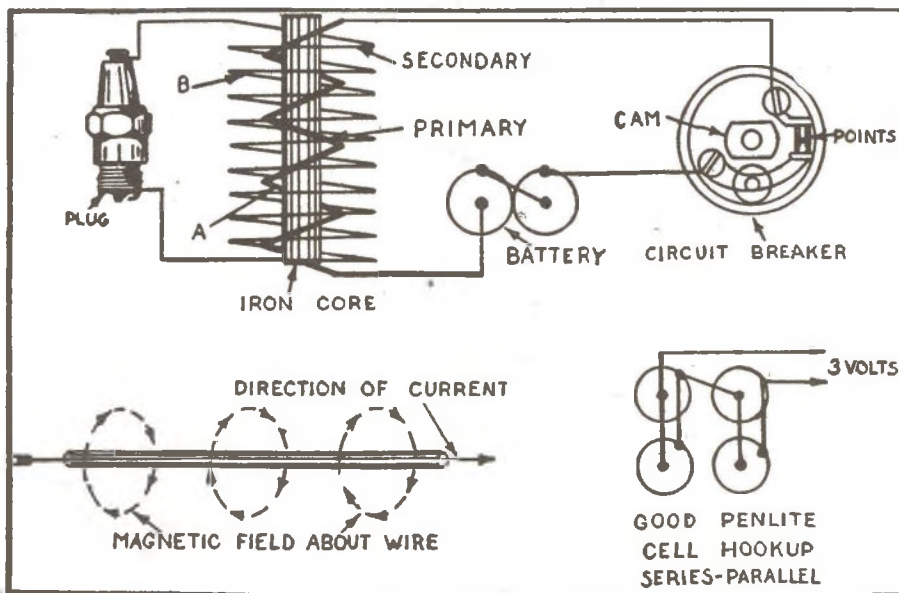

You'll like this

Aeronca Profile Flyer

Wind 'er up, let 'er go—then
remember that we told you so!

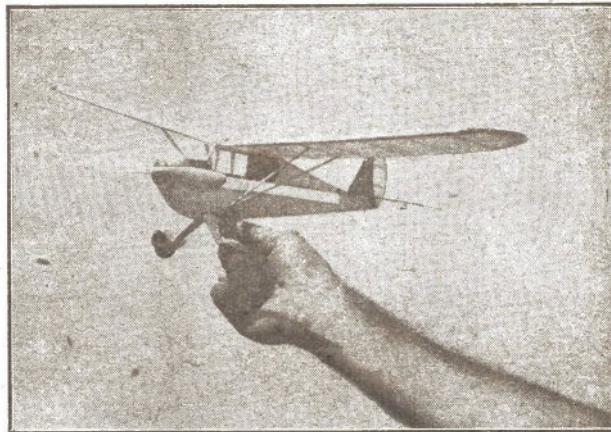

The ship is a fine outdoor performer and exceptionally stable.

BY REX HALL

MODEL BUILDERS in search of types easily adaptable to model work invariably turn to ships of the light plane field. In doing so, the writer has chosen a popular job of this classification and produced it in profile scale. The chief advantage in this type of construction is that much weight is eliminated and good flying still retained.



A true prototype, it embodies well-designed construction.

FUSELAGE CONSTRUCTION

BEGIN BY laying the two sections of plans on a flat board. The fuselage is made almost entirely of $3/32$ " sq. hard balsa. After cementing each strip of balsa in place, allow sufficient time for cement to harden. It is a good idea to place a heavy flat object on the top of the assembly while drying, to prevent warping. The nose section is the most important part of the fuselage, it is made up of six different pieces cut from $1/4$ " sheet which are glued in position and are later cut and sanded down into shape. It is best to allow the laminated parts to dry thoroughly before cementing them.

The nose plug is a conventional one, with the sides of the base cut off. Bend the rear hook from No. 14 piano wire and glue in position as indicated on the plans. There are four other wire braces, two on each side of the fuselage which hold the body in position after the model has been

wound up and ready for flight. The landing gear struts are cut from $1/8$ " sheet and sanded to shape. Using stringy grained wood will help take up the shock jolts imposed on the landing gear.

No. 8 piano wire is used for strengthening the landing gear, as indicated on plans. The wheels are $5/8$ " diameter, hard wood or balsa. The pants covering the wheels are made of laminated $1/4$ " sheet balsa in the following manner.

First, take a piece of $1/4$ " sheet and cut it to the required shape. Then cut the round section out where the wheel is placed and a piece of $1/8$ " sheet to each side of the center section. These are finally cut and sanded to shape.

WING AND TAIL

THESE surfaces are constructed in the same manner as for any other rubber powered model.

Begin the wing, by making one panel at a time. The ribs are cut from $1/32$ " sheet medium hard. After the bottom spar is laid the ribs are placed in position. Next, the leading, trailing, and top spars are added. The last section of the wing, are the tips which are cut from $1/8$ " sheet. The wing tip outlines may be traced onto the wood directly from the plans.

Note that the tail surfaces are made entirely of $1/16$ " sq. stock. Allow sufficient time for the cement to harden. Place a heavy flat object on top of the assembly while the parts dry to prevent warping.

ASSEMBLY AND FLYING

A ONE INCH dihedral angle is required at each tip.

Care should be given in lining up the parts correctly by checking with the drawings. The builder himself can best decide as to the color scheme best for his model. Don't put too much paint on the ship because of the weight and warping tendencies.

Solid parts such as the nose, landing gear, wing, and tail tips can be painted as indicated on plans by a dotted line. Yellow paper can be used for covering. The color generally used by the original Aeronca is yellow, striped with black. Motive power consists of six strands of $1/8$ " flat brown rubber.

The flying qualities of the ship will be bettered if the propeller is carefully selected. The prop shown on the plans may easily be carved. However, if you are not experienced in making props, it would be advisable to use the machine carved variety.

The machine-carved propellers usually come with rather thick blades. In this case, simply use a knife or razor to whittle down to correct proportions. Finish the prop by a gentle rubbing with both coarse and smooth sandpaper.

Test glide the ship correctly before flying it under power. Flights always begin with the nose of the craft directed into the wind. Careful inspection should follow each flight as a safety measure. The writer is almost positive that when you have finished this little job, you'll be sold on its construction and flying ability.

THE END

Simple features all add up to give this craft realism.

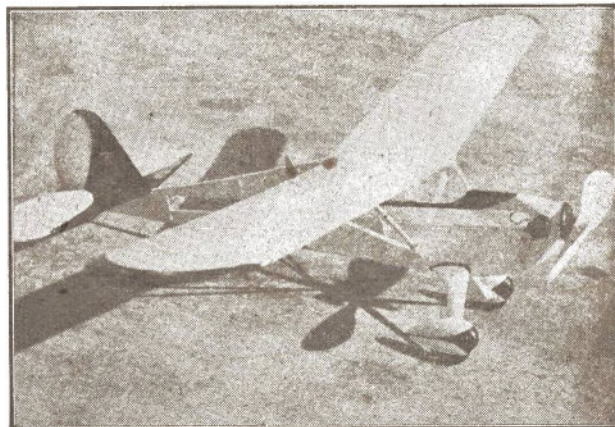

HERE'S A JIFFY-BUILT PROFILE FLYER—Plate 1

(PROFILE CONSTRUCTION)

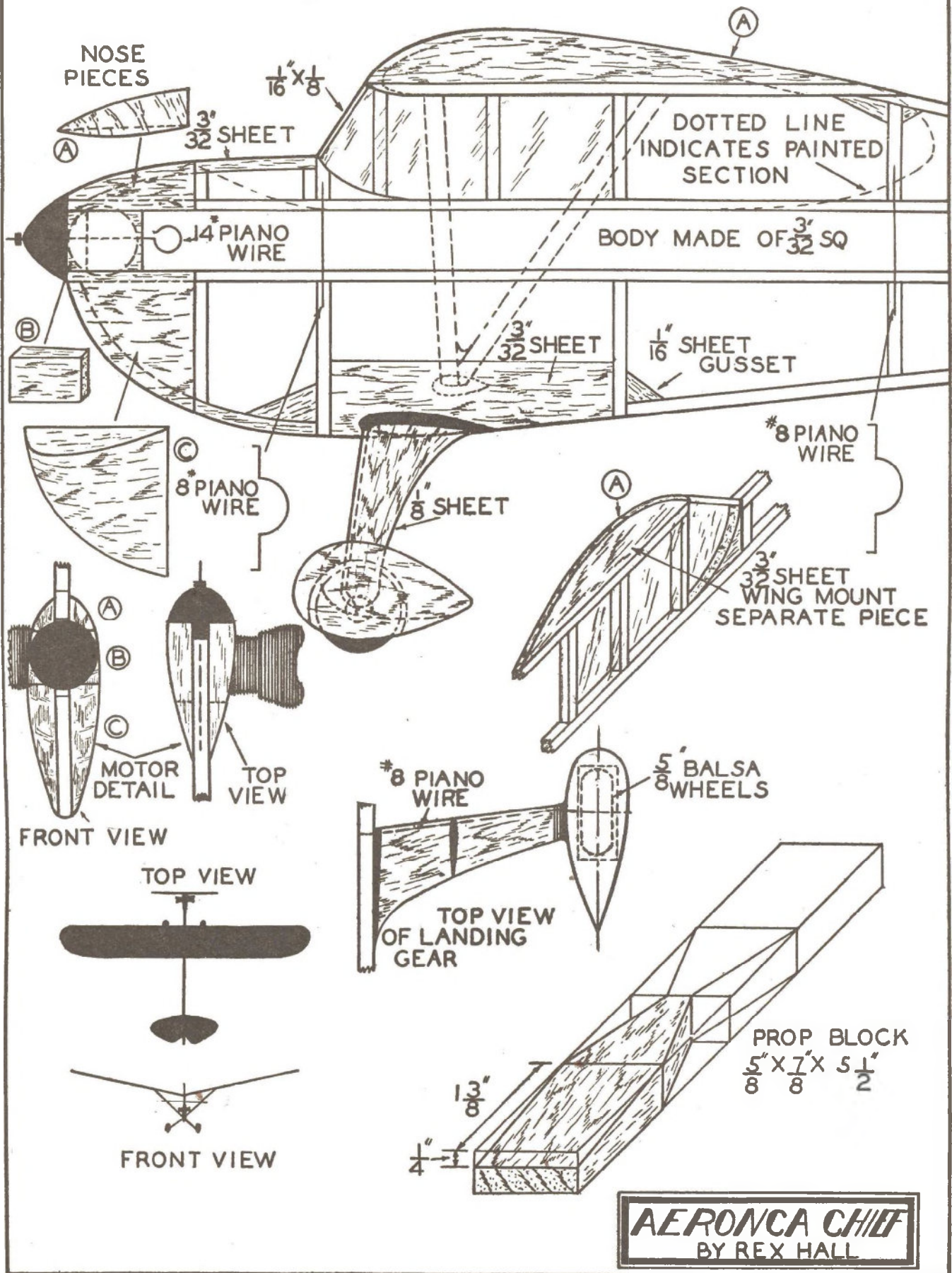

HERE'S A JIFFY-BUILT PROFILE FLYER—Plate 2

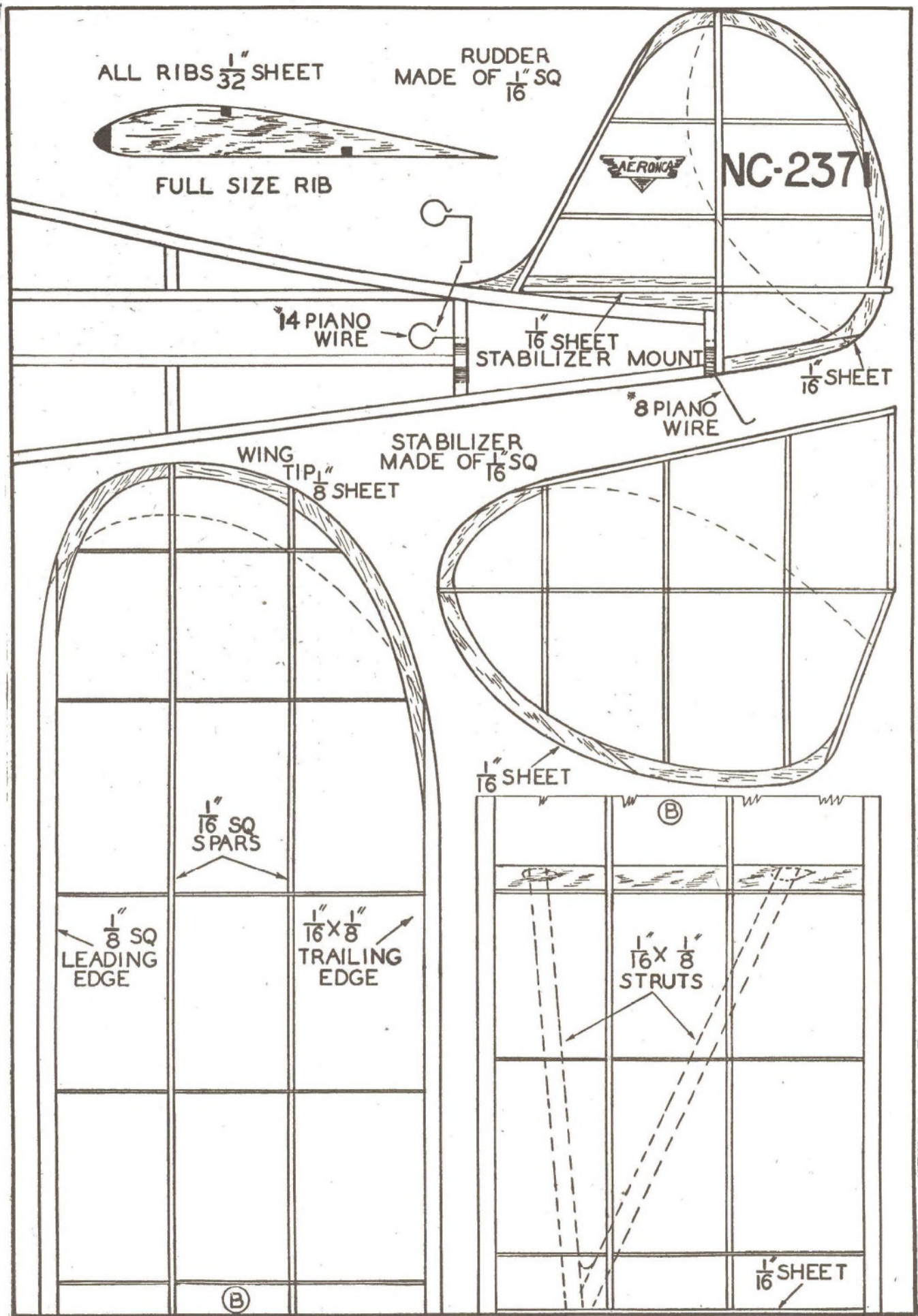

You Said it!

Here's your corner, buzzards, and it's open to all readers who have a model argument they want to get off their respective chests. Make your comments short and snappy, and we'll try to squeeze 'em in.

Want World War Jobs

Model Editor, FLYING ACES:

I suppose we World War model fans are in the minority, according to the letters published. But I hope other readers of this column will string along with me and shoot in their letters howling for the old-time jobs. I think the old Fokkers, Spads, Nieuports, and Camel models look a lot better than these sleek modern jobs that are a cinch to build.

NORMAN DELFEL,
Portland, Ore.

Model Editor, FLYING ACES:

Like many other model builders around my district I would like very much to see first World War plans

printed in F.A. Many of us younger fans who have just made our way into this model building hobby have become acquainted with aviation by reading true life stories of first World War aces and their famous Spads and other ships.

Why not run a poll to test the advisability of publishing plans for first World War planes? This letter speaks for the thirteen members of our recently organized model airplane club.

VINCENT PIPER,
Yonkers, N. Y.

Editor's note: The staff of FLYING ACES model department is always willing to cooperate to any extent with the wishes of its readers. If your requests for certain material are strong enough, the model section will be revised to suit the convenience of its model builders.

"Whisper" Praise Loud

Model Editor, FLYING ACES:

I built Ernie Copeland's "Whisper" and I think it's a swell ship. I've made two so far and am planning a third because I know that they're depend-

able for good flights. Let's have more gliders now that nice weather is coming.

DWIGHT HARTMAN,
Argenta, Ill.

More "Moth" Votes

Model Editor, FLYING ACES:

Here's another vote to reprint the plans of the "Moth" (August, 1937, F. A.). This goes for the rest of the Balsa Bug Model Club of which I am president. I've read F. A. for two years but have built only two or three of your hand-launched gliders. The best of these is the "Baby Glider" (November, 1938, F. A.). This little fellow flew out of sight. The second one I built wasn't so good.

RICHARD M. PINCHES,
Chicago, Ill.

Model Editor, FLYING ACES:

I've been buying F.A. for seven months, and from now on I promise to be a faithful reader. During those seven months I've made from F.A. plans four of the best models a fellow could ever build, and now I'd like to try the "Moth" of which I've been

Logging the Motor Market

Comet "35"

A RECENT addition to the ever-growing number of gas engines, the Comet "35," falls into the Class "C" category. It has a cubic inch displacement of .35 and a 1/5 h.p. rating. Its bare weight is 7 1/4 ounces, and with coil and condenser the flying weight is 10 1/2 ounces.

The cylinder is machined from solid bar stock alloy steel. The piston is machined from solid stock of special cast iron, and is honed and lapped for individual cylinder fitting. Solid alloy steel is used for the counter-balanced crankshaft, hardened, and ground to a fine tolerance. A special bronze alloy is used in the wrist pin. Extra-large bearings are used on the connecting rod and wrist pin. The motor features an enclosed timer which is guaranteed dirt proof.

A remote control rotary needle valve assures a fine mixture at all

engine speeds. The suction-type gas tank is transparent. The exhaust manifold is brazed onto the cylinder and the main bearing is of a special type bronze.

The timer is long enough to permit operation without getting too close to the propeller or hot motor. Two gaskets are used on the engine to eliminate compression leakage.

Cylinder fins make for efficient cooling even when the engine is flown wide open on hottest days, according to releases. The best operating speed is between 6,500 and 7,500 r.p.m. with a 13" diameter propeller.

Fuel parts are three or four parts white gas to one part SAE 70 oil. Bore is .765 inches and stroke .763. The engine is block tested before shipment.

Bunch Tiger Aero

SEVERAL NEW features have been incorporated into the 1941 Tiger Aero. Extra performance per cubic inch, Bunch engineers state, has been gained with this engine by the use of ethyl and high octane gasoline. The Tiger has a compression ratio of 7 1/2 to 1.

Bunch engineers recommend the following fuel as best: Sixteen ounces of ethyl gasoline to eight ounces castor oil and one ounce ether. The ether is used only to blend the castor with the gasoline. This is not only a better performing fuel, it is claimed, but will give longer motor life and better lu-

brication. An extension on the intake tube to establish a column of air past the fuel jet when using this formula is standard on the latest Tigers.

Conventional lubrication at the main bearing was found inadequate at increased r.p.m. and a spiral cut was made in the surface of the bronze bearing to accomplish force-feed lubrication. Also, a safety hub nut to prevent the propeller from flying loose was developed.

The latest model Tiger also has a new crankcase with two vertical ribs on each side to brace the mounting ears to the main body of the aluminum casting. In recent tests at 8,500 r.p.m. with a 12" propeller, the Tiger registered 44/100 h.p., or nearly one horsepower per cubic inch. The Tiger is in the middle of Class "C" in displacement.

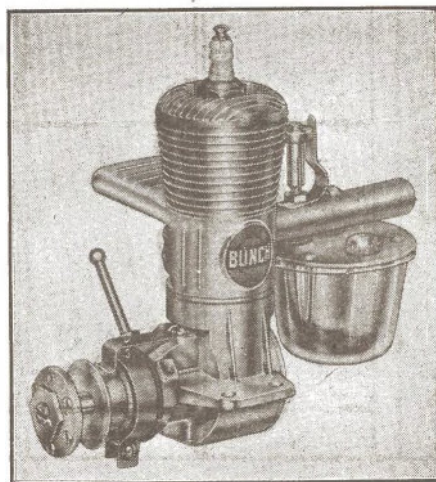
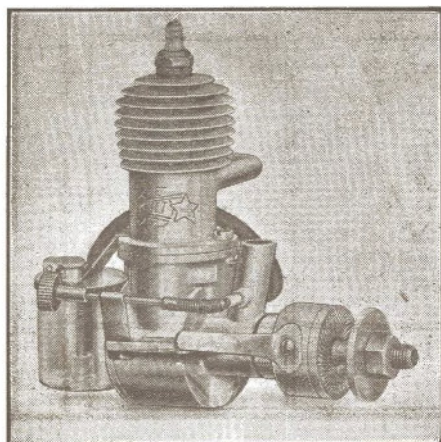

Left: Here's the new Comet "35" Class "C" engine. Right: The Bunch Tiger Aero Class "C".

reading so much about. How's about helping me with plans boys?

HUGH WALDBAUER,
2140 Grey Ave.,
Montreal, Can.

Model Editor, FLYING ACES:

My cousin built a "Moth" and it lasted nearly two years. So maybe Tommy McCabe knows a good ship, too. I speak for a whole group of us, and this letter means ten more votes toward hastening the re-issue of the "Moth" plans.

HAROLD OLSON, JR.
Spring Valley, Wis.

Model Editor, FLYING ACES:

Those wise guys who said the "Windmill Plane" (March 1940 F.A.) is no good are not so wise after all. I built that "tulip twister" and she flew beautifully. How *moth* longer do we have to wait until the "Moth" plans are published again?

EDDIE KLECZEWSKI,
Rockford, Ill.

The response from the readers of FLYING ACES to have the "Moth" reprinted has been very satisfactory. In view of this, the plans and instructions for this popular outdoor cabin job will definitely be published in the August issue.

Model Editor, FLYING ACES:

Would someone please send me plans for the "Kiltie Gull" (January, 1939, F. A.) and the "Kaydet" (June, 1939 F. A.). Thanks.

BILL SHIE,
20942 Avalon Dr.,
Rocky River, Ohio

Model Editor, FLYING ACES:

Will you be kind enough to help me out in my extreme grief? I'd like some fellow to kick in and barter

some "Hi-Climber" plans (August 1939 F.A.) for the "Moth" plans.

I am building the "Hurricane" (July 1940) and everything went along fine until I lost the wing and tail plans, and I need those drawings to finish the erate, so how's about it, boys?

JIM MCNAUGHTON,
P.O. Box 302,
New Alexandria, Va.

Model Editor, FLYING ACES:

Why don't you reprint the plans for the "Hi-Climber" (August, 1939, F. A.). I know that many other wood choppers would like to take a crack at building this fine outdoor craft. If you can't do this, would one of your readers be good enough to lend me his set? I'll return them as soon as the ship is built.

DONALD MINOW,
3221 Ainslie St.,
Chicago, Ill.

Model Editor, FLYING ACES:

I've been reading your mag for a number of years and I think you need more solid scales and three-views. A few years ago hardly an issue went by without one or two in it. You must be slipping.

RICHARD BUESCHEL,
Chicago, Ill.

Model Editor, FLYING ACES:

I started to buy your mag back in '38 and have read all of them since then. Somewhere I slipped up, missed the Messerschmitt (March, 1936, F. A.). Would one of you fellows be kind enough to send me this set.

RUSSELL WARR,
7552 Cadillac Ave.,
Van Dyke, Mich.

Model Editor, FLYING ACES:

I haven't been reading your magazine very long but recently have become interested in model planes. I'd

like to build the "Windmill Plane" (March, 1940, F. A.) and the "Parlor Fly" (October, 1937, F. A.). I hope some modeler can send me these plans. I think, too, that you should enlarge your "Workbench Tips."

LOWELL BALTZELL,
Bristol, S. D.

Model Editor, FLYING ACES:

Would some kindhearted fellow modeler send me drawings for the "Teardrop Stick" March 1939 F.A.?

JIMMY COX,
702 West Second St.,
Mt. Vernon, Ind.

Model Editor, FLYING ACES:

Reading some of the letters the boys have been sending in regarding the virtues of the "Sky Gull" (September, 1938, F. A.), the "Moth" (August, 1937, F. A.) and the "Hi-Climber" (August, 1939, F. A.), I want very much to build all of these models. And, much as I hate to, I'll part with my plans for the "Snoony" for any one of those drawings.

JOHN MARINELLI,
221 Lindsley Ave.,
South Orange, N. J.

Workbench Tips

Helpful Jingles

A colored comb,
Some acetone,
A bottle and some ether.
Dissolve the comb,
With the acetone,
And Dope is what it'll be, Sir!

Little chunks of celluloid,
And a drop of camphor, too,
Dissolved in a bottle of acetone,
Make dandy model Glue.

JOHN DALLAIRE, JR.
Medford, Ore.

THROTTLE BACK AND SLIPPING

for the

Next Supreme FLYING ACES

FACT—"N.C.O. Pilots—Why Not?" is the title of Major Fred Lord's dramatic lead article. We've long had a pet peeve against the way Flying Cadets are chosen for the Air Corps, and in this no-punches-barred feature Major Lord airs all of them in his straight-shooting style.

And as a special treat for you fact fans, we'll have **NINE** other articles. July FLYING ACES will be the most feature-packed yet. Don't miss it!

FICTION—Those night-flying hellions again—Kerry Keen and Barney O'Dare.
Plus another phenagling Phineas fun fest.

MODEL BUILDING—Stinson Voyager flying scale by Jerome Jacobs.
Herb Lozier's latest cardboard replica.
"R.O.W. Indoor Floats" by Robert Abrahamson.

In July FLYING ACES

On Sale May 23 (Canada One Week Later)

LURE OF THE LIBERATORS

(Continued from page 17)

Trent nodded. "I know. Range 3,500, top speed 340, power-driven .50-caliber turrets, four tons of bombs, ceiling 36,000 and other highly secret details that everybody knows. By the way, just what happened to the Liberator that left La Guardia Field and never reached England?"

Both Woring and Busby gave a start.

"How'd you know that?" demanded the general.

"Private Intelligence service. Was that your Purple Legion?"

"It was," growled Busby. "Five minutes after it took off, we received an anonymous message signed 'The Purple Legion,' saying the bomber was doomed. We tried to contact it by radio, but they never answered. Nobody ever saw it again."

Trent glanced past him, at the open door of a hangar.

"So now you're sending them off from here, under Air Corps auspices?"

"The RCAF is taking them over after factory pilots fly them to Bolling," admitted Busby. "But there's more than just an Atlantic ferrying job to it. The Nazis have two surface raiders in the North Atlantic. British Intelligence thinks it's learned their approximate area of operations. These bombers are going over, with a full load of eggs, hoping to spot the raiders. They're going to spread out and cover a 180-mile lane. If they don't find the Nazi warships, then they'll unload their eggs on the French and Belgian invasion-ports before making a landing in England."

"A neat scheme," said Trent. "And the Purple Legion is threatening to spoil the party?"

"You're a good guesser, Mr. Trent," Woring said stiffly. "Almost too good."

"Oh, it's really nothing. Anyone can do it with a little practice." Trent winked at Mortimer Crabb, looked back at the general. "When do the Liberators take-off?"

"Pretty soon. The ships will be ready in an hour, but we're waiting for a British Embassy attache. He has to take the senior pilots to the Embassy for special orders. All the RCAF men were flown down here from Canada."

Woring looked at his wrist-watch. "The attache should be here by now." His eyes shifted back to Trent. "You have no clue to the identity of the men whom you say attacked you?"

"Eric, you've forgotten about the key!" broke in Crabb. "That ought to—"

"How stupid of me," said Trent. "I completely forgot. When I searched the man who was killed I found a hotel key—but I was in such a hurry

to get to the gyro I didn't even notice what hotel it was. I left it back there on a workbench."

"And you call yourself smart!" fumed Busby. He spun around, shouted for an orderly. "Get my car!"

"No need for that," said Trent. "We can fly back in the gyro and land there before you could even reach the bridge. I'll phone you the name and room number, and anything else we find."

"All right, I'll be at Operations," said the general.

Trent turned to Crabb, who was looking at him goggle-eyed. "Hop in, Mort. Leaping Lena awaits."

CRABB climbed in, and Trent was halfway into the front cockpit when a long black car halted at the edge of the line. A heavy-set man with a briefcase jumped out, hurried toward Woring and Busby. Woring raised his hand in a hasty gesture.

"Ah, there's Captain Smythe now," exclaimed Busby.

Trent stood motionless, staring at the newcomer's grim, blocky features. Mortimer Crabb's jaw had dropped in sudden amazement.

"Smythe!" Trent said incredulously. "I thought you were dead!"

Smythe jerked to a stop, glaring up at him and Crabb.

"You butchers! So it was you who killed Luttre and Cheval to hide what you did to me!"

General Busby gaped at him. "What's this? I don't underst—"

"They're traitors!" Smythe broke in savagely. "They sold out to Hitler—betrayed me to the Gestapo and left me for dead one night in Brussels."

Busby wheeled toward the gyro, a stunned look on his face. "Trent, in the name of Heaven—"

"I tell you they're killers!" rasped Smythe. "Trent's the secret head of the Purple Legion! We just learned how they killed Rene Cheval, landed that gyro on his pent-house—"

The guard detail was running toward the scene, with the crowd at their heels. Trent flung himself down at the controls, snapped ignition and starter switches.

"Stop them!" bawled the general. "Don't let them take-off!"

The roar of the engine drowned the rest and Trent swiftly locked in the rotor. The gyro's vertical leap took them clear just in time. Rifles blazed below. Trent transferred power to the propeller, and the ship thundered away in a steep climb. By the time the searchlights came on, the gyro was in the edge of the clouds.

"Now you've done it," groaned Crabb. "You nincompoop, do you realize we're fugitives from justice?"

"Fugitives from three shots in the back, you mean," amended Trent. "For a second there, Mort, we were

almost finished by those boys."

"And what are we now?" Crabb moaned. "It was bad enough, having Smythe come back like that, accusing us—"

"Don't worry your gray matter over Smythe," said Trent. "We've a job to do. How long will it take you to hook that smoke-screen gadget up in this bus?"

"Maybe half an hour, for temporary use. But what's that got to do—"

"A lot—but we can't spare half an hour. You'll have to fix it after we take-off. They'll be after us like hornets."

"Why didn't you stay there and explain to Smythe?" insisted Crabb.

"From the looks of things, you and I would have been reposing in a cell—or on a marble slab—before midnight. And I'm opposed to both as a matter of principle."

"Do you realize Smythe actually thinks we sold him out? He thinks we did what we know Cheval did, and that we got rid of Luttre and Cheval to cover up."

"After the bullets that Nazi put through him that night, it's a miracle he's here to think at all," said Trent.

"We can straighten out matters with Smythe later. Right now, I'm wondering about that P-40 pilot. If he bailed out, he may have been ordered to go to our place and remove the evidence. They obviously tipped him off by radio from some secret short-wave station near here before he attacked us, and they might do it again."

"Who tipped him off?"

"Whoever engineered that attack on us. Probably the Nazi who escaped in our car got to a phone and called their short-wave station, so they could warn the P-40 guy to be on the look out for us, to keep us from spilling the well-known beans."

"It's getting too deep for me," Crabb said dismally. "You said somebody was trying to get rid of Luttre and Cheval and us to cover up the Brussels business. And now Smythe pops up—"

"Did you notice the mud on that Stratoliner's wheels?" Trent broke in suddenly.

"No. Anyway, what of it?"

"I'm beginning to get a glimmer—but we'd never convince Busby if we went back now. We'll have to go it alone."

Trent warily let down through the overcast, swung back, and began an almost vertical descent toward the mansion. One or two blips of the engine carried them into position for a landing inside the wall.

The shattered gate lay where it had fallen, and there was no sign of anyone in the grounds. Trent left the engine idling, and they made their way to the basement.

"I'll switch off the fog-light," said Trent. "Hook that smoke-screen release tube up to a small tank that we can put in the ship, while I get a couple of automatics." Trent set out in search of the fire-arms.

CHAPTER III

THE PURPLE LEGION

CRABB QUICKLY set to work. Trent went upstairs, to a huge closet they had converted into a storeroom. Several souvenirs of the European war were piled in one corner. A chest of magician's paraphernalia and props stood in the other, near a locked case. He took two .38's from the case, delved into the magician's chest. Slipping a ring of skeleton keys into his pocket, he took off his coat and fastened on a shoulder harness with a dangling strap and a rubber tube ending in a bulb. Then he bent over a compartment filled with prop pistols, knives, magnetized wands, and other implements.

A few moments later, coat in place, he left the closet. He was starting for the stairway when the phone rang shrilly. He picked up the handset.

"Le Fung Lo, laundlee," he said in a singsong tone. "What you want, pleece?"

"Damn that operator!" came General Busby's infuriated voice. "Gave me some blasted Chinese laundry."

The receiver crackled as he hung up. Trent grinned, went downstairs. Crabb had already carried the smoke-screen apparatus out to the gyro, and was at work in the rear pit.

"I've got the tank behind the rear seat," he told Trent. "Poke a hole near the tail and I'll slip the tube back there. I'll connect the valve to the other end after we take-off."

In another minute the tube was in place, and Trent climbed into the pilot's seat.

"Hold on!" the inventor burst out. "Before we start on any more lunatic rides, I want to know what's up. Why'd you want that smoke-tank?"

"I'm going to do a little skywriting, to a blonde over in town," Trent said confidentially.

"Don't be funny! Anyway, that smoke's black—it won't show at night."

"That's all right. She's so dumb she won't know the difference."

"If you think I'm going with you without even knowing what—" Crabb's angry protest ended with a gulp as Leaping Lena jumped into mid-air and started across the wall.

"As you were saying?" queried Trent.

"Go ahead," Crabb said bitterly. "Land me in jail. Get me executed for murder and treason. I deserve it for ever tying up with a maniac like you."

"If you insist, we're going to pay a little call, over at the Plaza-Grand."

"You don't mean we're going to land on the roof?" Crabb said in dismay.

"Why not? It's a trifle small, I admit. But I've seen a couple of hundred dancers packed together on it, when the roof-garden was open. Fortunately for our purposes, it's not quite roof-garden weather yet."

"If I had a parachute, I'd leave you flat," Crabb said morosely.

"It'd be a trifle chilly, dropping into the Potomac tonight. Here, take this guide-book and help me spot the Grand-Plaza when we get

over Washington," Trent answered. "What if people see us landing?" "People never look up that high unless they see lights or hear noise. We're going to omit lights and come in dead-stick."

Crabb groaned, bent lugubriously over the guide-book. They cruised across the Potomac, came in over Georgetown, and angled South over the city. Trent climbed close to the clouds. He had located the Grand-Plaza and was about to cut off the engine for a silent landing when without the slightest warning the RCAF P-40 charged out of the mists above them. But for his jerk at the throttle, the gyro would have been caught in that first furious burst.

Trent hurriedly swung toward the river, engine now full on. This time, Mortimer Crabb needed no urging. The rear-pit Browning clattered into



"Ye gads! A black cat!"

action as the fighter whipped around in a vertical bank. Trent saw his solitary tracer-stream go wide of the twisting P-40.

"Give him the smoke," he shouted.

The gyro trembled as solid slugs from the P-40's guns drilled the turtleback. Tracers scorched over Trent's head for an instant, then they suddenly veered off. Trent saw the black smoke spurting from the gyro's tail and he swiftly nosed down as though the ship were hit. The P-40's guns went dark. With a violent zoom, Trent jerked the gyro's nose up at the fighter, and his thumb rammed the stick-button.

Streams of hot lead followed by phosphorescent tracer slugs streaked steadily at the bull's-eye markings on the Canadian craft.

THE RIGHT WING of the P-40 crumpled under a direct hit, and the wrecked fighter pitched onto its side, went plummeting down toward the river. Trent pulled the gyro up to the very edge of the clouds, swinging in a wide circle. Mortimer Crabb had shut off the chemical smoke.

"Well, I hope you're satisfied," he said gloomily. "Now we've got another crime chalked up against us."

"Don't let your conscience bother you," Trent told him. "I could knock off a dozen killers like that and still eat a hearty dinner. And speaking of dinner, it's just dawned on me that I'm starved."

"How can you talk of eating at a time like this?" Crabb shook his head. "I suppose you had this all figured out, to use the smoke like that."

"Well, it was the general idea—sort of a cuttlefish trick to protect ourselves if we met somebody we couldn't handle. But I didn't expect anyone to believe we were on fire. Can't think how I overlooked the possibility."

"Your brain must be slipping," Crabb said sarcastically. "That is, if it still has anywhere to slip to."

"I'm afraid you're right, Mort," Trent said in a contrite tone. "I've handled this pretty badly."

"What are you up to?" Crabb said with suspicion. "First time I ever heard you admit you'd made a mistake."

"Just thinking maybe I'd better land somewhere else and drop you off, before I head for the Plaza-Grand. You can wait and see—"

"Are you intimating I'm scared to go through with this?" roared Crabb.

"Not a bit, old bean. But I'll admit it's a cockeyed notion. All I've got to go on is a hunch. If we're caught this time, well—"

"We're not caught yet," snapped Crabb. "After what I've been through in the last two years, I guess I can stand another night of it."

Trent smiled to himself. He had known that the inventor would stay on the job with him.

"Mort, your bark's worse than your bite."

"Never mind my bark. Go ahead and spot that hotel again. If my figuring is anywhere near right, we'll only have about five minutes before a car could reach there from Bolling Field."

"Two minds with one thought. Well, here we go."

Trent let the gyro hover a few moments to get the wind drift. Then he started down toward the hotel roof. Washington was a maze of lights, with the Capitol dome and the Washington Monument standing out prominently.

Engine silent, the ship settled perpendicularly the last hundred feet. Trent brought the nose up in a last-second stall, and the gyro dropped lightly onto the roof. He set the park-

ing-brake and took a quick look around. There was no one in sight.

"Seems to be okey this far," he whispered to Crabb. "Here, take this .38. If we get in a jam, use the butt unless it's necessary to shoot."

The inventor followed as Trent tiptoed across the roof for a hurried glance down into the street, ten floors below. No one was looking up as far as could be seen.

"Come on, we'll have to move fast." Trent led the way to the service rooms which were used when the roof-garden was open. The door was locked, but it yielded to the second master-key he tried. He left it slightly ajar, and they crept down the service stairs.

"Two floors below," Trent said in an undertone.

WHEN THEY reached the eighth floor, he peered out cautiously into the hall. A bellhop was coming down the corridor with a telegram.

Trent waited until the boy had delivered it and left, then motioned Crabb to follow.

A light showed over the transom of Room 817, and a muffled voice was faintly audible from within. Trent put his ear to the door.

"It's our killer friend—the one who got away," he whispered to Crabb. "I think he's telephoning someone, but I can't hear what he's saying."

He tried again, then tiptoed to the room adjoining 817 and took out his keyring. An adjustable master-key slid noiselessly into the lock, and a moment later the door swung open.

"Lock it, while I try that connecting-door," he told Crabb in an undertone.

The connecting-door was locked on the other side, but the voice of the Nazi killer was louder now. Trent heard a guttural "Thanks," then a brief silence. It was followed almost at once by the jangle of the telephone

bell. There was a brief interval.

"Hello," the unseen Nazi said. "Yes—this is Schill. Where are you?"

Another brief interval, then:

"Don't worry about those two. I just called one of the newspaper offices, after I heard about that air fight. They caught on fire and fell in the river. . . . *Ja*, the fighter did, too. But maybe it is a good thing. We don't need him any more. . . . Yes, I tell you it is safe up here. No police have come, or anyone. . . . Yes, I can look in the lobby before you come up."

The phone clattered onto its cradle, and Trent heard the door of 817 open and shut.

"Come on, here's our chance," he whispered to Crabb. They waited a few seconds, then went into the hall. Trent unlocked the door of 817, made a quick survey of the room. The light was still on and a packed bag stood at one side. There was a flat leather packet beside it.

"Listen for the elevator," Trent told the inventor; then he hurriedly opened the packet. A carefully drawn sketch lay on top of a folded map. He recognized at a glance that it was a chart showing the location of their Virginia retreat. He opened the map, saw that it covered Washington and its suburbs. Replacing both papers, he quickly opened the traveling bag. A gun with a Maxim silencer met his eyes first. Between the wadded up shirts beneath it were several Tommy-gun magazines, loaded.

"Look out—someone's coming!" Crabb said hoarsely.

Trent snapped the bag shut, sprang to the door. He had barely time to lock it and follow Crabb to a fire-escape alcove diagonally across the hall when the footsteps of three or four men sounded.

"If you hadn't bungled your job, this wouldn't have happened," he heard Woring's surly voice. The man was speaking German.

"Keep quiet," another muttered. Crabb grasped Trent's arm.

"Isn't that Smythe?" he whispered. Trent nodded, risked a swift glance as he heard the door of 817 open. Schill, the Gestapo agent, stood at one side, with a smaller man whose beak nose and close-set eyes gave him a hawklike appearance. Woring and Smythe were halfway into the room.

As the door closed, Trent and Crabb silently re-entered the adjoining room. Trent leaned against the connecting-door, heard Schill's protesting voice.

"It wasn't my fault. How was I to know they had a lot of trick lights and sirens down there? They all went off at once and I thought a Stuka had hit the place. The light blinded me—"

"It's done now," Smythe said coldly. "Thanks to good luck—and my quick thinking—it didn't ruin us. I managed to scare Trent and that sour-faced partner of his into running for it, so Busby and the rest of them don't suspect anything."

"What if Trent called Busby and

Hobby Becomes Career

by Robert E. Moore

PUZZLED, the buyer of Canada's largest department store gazed at the earnest, fast-talking, eighteen-year-old boy. "What the heck kind of a salesman is this?" he thought. "Why, he's just a kid!"

Seeing the quizzical look on the buyer's face, the boy pepped up his carefully prepared spiel.

Finally, the buyer grunted assent. "I'll take 500."

The boy gulped. "500?" He had hoped that with a bit of luck he might have landed an order for 50 model plane kits.

That order of 500 was the first production contract Frank Lucas had received, and it launched him into a business which in eleven years has grown into the biggest of its kind in the British Empire. Working until 2 a.m., with his mother and sister as his only helpers, Lucas managed to fill that initial order in ten days.

Most unusual feature of the three two-story factories he owns today is that the average age of his 40 employees is 19. Every employee is a model plane enthusiast and is in love with his job.

Four salesmen are the only ones on the pay roll who couldn't be called young. Frank was disappointed to find that most buyers didn't like dealing with boys.

Frank's theory—and it seems to work—is that it takes youth and youth's imagination to make and design model planes. Other Canadian manufacturers have just about given up trying to compete with Frank and his crew of zealous henchmen—or should it be hench-boys?

Seeking an artist to do pictures for kit boxes, Lucas refused to see a commercial artist. He scouted around until he located a nineteen-year-old boy in a sign painting shop. Studying art at night, this lad jumped at the chance to join Frank.

Another time he needed a draftsman. One boy in the shop displayed an interest in designing, but was untrained. Frank talked to him and suggested that he take a night course in drafting. The boy did. Later, Frank promoted him to designing.

Needing a bookkeeper, Frank once buckled down and did the job himself until one of his own crew was proficient.

Embroiled in war, one of Canada's greatest needs has been for flyers and potential airmen. Heeding the call, 19 of Frank's boys left and joined the RCAF.

Thousands of youths in such far away corners of the world as Singapore, South Africa, and virtually every point of the far flung British Empire support Frank's faith in youth and their ambitions by flying his planes.

Since organizing, he has answered 200,000 letters from these boys. Assuming 300 working days to a year, that is an average of 60 every day.

In 1939 total production for the year was 1,000,000 kits; 1,500,000 was the predicted total for 1940.

As business grows larger, so do the pay envelopes of Frank's 40 youthful cohorts who see eye to eye with him in his belief that it takes boys to make model planes for other boys.

gave him a warning before they crashed?" Woring asked in an uneasy tone. "Trent must have begun to see through it."

"Busby tried to call him, at the place in Virginia," Smythe answered. "He couldn't get any answer. It must have worked out just as I expected. Trent went back and found the key that Weiman had, and then he and Crabb started for here in the autogyro. We could probably have caught them before they asked the management too many questions, but Martz saved us the trouble—even if we did lose him."

"We'd better call Hans, at the field," Woring said anxiously. "I told him to be at that booth telephone in the canteen, so he could warn our men if anything went wrong."

"Go down and dial him from a lobby booth," Smythe ordered. "It was dangerous enough calling Schill on this line. Don't take any more chance that a hotel operator might listen in."

"I'm glad they sent you to handle this, Mannrich," Woring said nervously. "Creating that Purple Legion scheme was a masterpiece, and tonight I'd have been sunk if you hadn't turned the tables on those snooping fools."

"I've been a year training for this," Smythe answered, with a touch of complacency. "It naturally shows results. Go make the call. Tell Hans all is well, that the plan is unchanged. Tell him to have the crews ready to take-off the instant we return to Bolling Field. Then wait in the lobby. I'll phone Busby from here to have the engines warmed up and ready and then we'll join you."

TRENT STEPPED back from the connecting-door, felt his way through the darkened room to where Crabb was guarding the hall entrance.

"Woring's going downstairs. We'll give him a few seconds and then drop in on our friends next door. Have that gun ready—they're tough customers."

The hall was deserted when they stole out. Trent tried the knob of 817, turning it with infinite care. The door was unlocked. Pistol in hand, he flung the door open and sprang inside.

"Up with them, *mein Herren!*"

Smythe spun around, went rigid as he saw Trent's face. Schill and the hawk-faced little man stood paralyzed, their hands in the air.

"Sorry to startle you, gentlemen," Trent said pleasantly. "Mort, put the bead on *Herr Schill*. If he bats an eye, let him have it."

"You *Teufel!*" croaked the man called Smythe. "Will you never stay dead?"

Trent grinned. "I've an aversion to rigor mortis. Now suppose you three boys scrutinize the wall for a minute. Mort, go through Mannrich's pockets and see what you can find."

"Which one's Mannrich?"

"That rat in the middle—the chap who's been posing as Smythe. A clev-

er act, Mannrich, but you made a mistake trying to remove the four of us who were in that cellar. Probably none of us would have heard of you and wondered about 'Smythe's' coming back to life."

The German glared at him, but did not speak.

"Lord help me, I'd have sworn he was Smythe!" Crabb ejaculated.

"The Gestapo must have stumbled on a double of his," said Trent. "Smythe was on a lone-wolf assignment, and the British wouldn't think it was strange if he didn't show up for some time. I heard this fellow tell Woring—who's another Nazi, obviously—that he'd trained a year for this job. He probably worked to get the attache job here so he wouldn't be running into too many of Smythe's friends, as he would in London."

Crabb maneuvered around the impostor so as to search him without in-

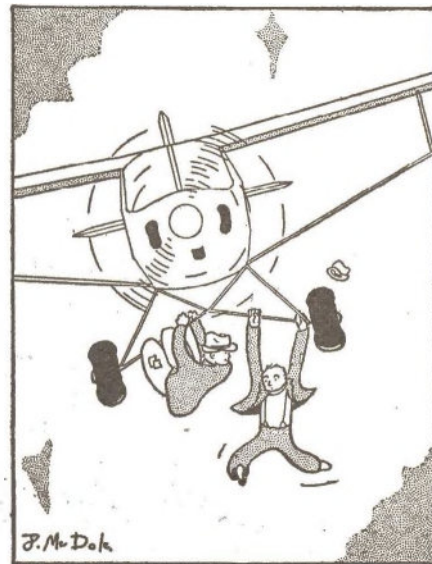

"I might be a little old-fashioned, but I still prefer to ride the rails on a box-car!"

terfering with Trent's aim. After taking out the spy's personal effects, he laid a manila envelope and a folded tracing on the desk.

"Open the envelope," directed Trent.

"Here's a confidential report on British convoy positions," Crabb said after a moment. "And a typewritten message signed 'The Purple Legion'—something about the end of aid to Britain. You think this guy's the real head of the Purple Legion?"

"This guy is the Purple Legion—hide, hair, and toenails. He made it up to cover their scheme for making off with American bombers. It's a hundred to one shot that they substituted Nazis for the crew of the *Liberator* that took-off from La Guardia Field. Probably that ship is over in Hitler's air force right now, raiding England."

Crabb's adam's-apple gave a convulsive jerk. "Then all those crews in Canadian uniform are Nazis! They're going to grab all six of the *Liberators* at Bolling!"

"They were going to, until we

horned in," Trent said affably. "And unless I miss my guess, they had a lot more in mind. Let's see that tracing."

Crabb unfolded the transparent sheet, and in a quick side glance Trent saw half a dozen red circles connected by a broken red line. Each of the circles was marked with a name, in German. The first circle was lettered "Bolling Field," but in that hasty look he had no time to read the other labels. Smythe's double had cautiously turned his head, was looking back over his shoulder. Trent flipped the .38 muzzle toward him.

"As you were, *mein Freund*. Mort, get on the phone and call Operations at Bolling Field. When Busby hears about this, his toupee will hit the ceiling."

"Don't forget he's got a dragnet out for us," Crabb said dismally.

"We'll be the little tin heroes when we turn in this mob," answered Trent.

Crabb stepped toward the phone. Just as he picked it up, there was a sound of running feet in the hall. Trent whirled, took a hasty step back, but it was too late. The door burst open, slamming his gun-hand against the wall. Before he could recover, Woring charged into the room, a pistol in his hand!

CHAPTER IV

DEATH ON THE DOTTED LINE

"DON'T MOVE!" Woring snarled. He jammed the gun against Trent's head, snatched the .38. Mannrich had leaped at Crabb, knocking the phone from his hand, and Schill seized the inventor's gun from the desk where Crabb had laid it.

"Let it go, operator," Mannrich said hastily into the mouthpiece. He cradled the handset, closed the door. "*Gott sie Dank!* If you hadn't come back—"

"The crash report was a mistake," Woring said tensely. "I heard a radio flash after I phoned, downstairs. It said only the fighter crashed. I came back as fast as I could. Then I heard Trent in here—"

Mannrich stuffed the convoy reports and the tracing into his pocket, wheeled toward the door.

"We've got to get out of here! If they landed that gyro on the roof someone may have seen it. The police might surround the hotel and we'd be trapped."

The hawk-faced German turned pale. Mannrich flung a taut look at Schill.

"You and Kurt take care of these two—use the gun with the silencer. Then get out as fast as you can, and report to the New York office later."

Before Schill could answer, Mannrich and Woring were gone. Kurt kept Mortimer Crabb covered, but the fear in his eyes grew swiftly.

"Did you hear?" he said huskily to Schill. "If the police come we can't get out—they've left us in a trap!"

"Stop your sniveling," the Gestapo man rasped. He covered Trent, felt behind him for the handbag. "We'll get this done and be out of here in two minutes."

"What if it's too late?" Kurt said in a shaking voice. "If we kill them and the police come before we get away, we'll be caught and electrocuted. They'd find we were in on what's going to happen tonight—we'd never have a chance with that added to a murder charge."

"We'll shoot them out in the hall. There'll be nothing to hook it up with this room," snapped Schill. "Even if the police did hold everyone in the hotel, they couldn't connect us—"

"Have you forgotten the powder tests? They can tell from your hands if you have fired a gun—even a silenced one—"

"You're right," Schill muttered. "We'd be in a trap. Get on downstairs—see if there's any sign of police. I'll wait—and don't try to run out without me, or I'll find you and slit your throat!"

Kurt scuttled into the hall and Schill braced himself against the connecting-door, where he could cover both men. From across the room, Crabb looked desperately at Trent.

"Don't try it, Mort," Trent said hopelessly. "He'll shoot if we try to rush him. Our only chance is the police—"

"Shut up!" rasped the Gestapo agent. His finger twitched on the trigger of his automatic. "And keep your hands up!"

Three minutes dragged by. Perspiration stood out on Schill's forehead, but his unblinking eyes did not leave the two captives. In another minute or two Trent's arms began to sag.

"Hold your hands up!" Schill repeated savagely.

"I can't keep them up," Trent mumbled. "Try it yourself sometime."

Crabb's arms were also shaking from the effort to force his weary muscles. Schill glowered at the two men.

"All right, but make one move and you're through."

Trent let his arms drop slowly. He could feel the rubber bulb in his left sleeve compress slightly as his elbow touched his side. If only Schill would relax for a second. . . .

Ten more minutes passed. Schill swore under his breath, then a sudden look of decision came into his eyes. He reached out toward the traveling-bag with his left hand, fumbled with the catch.

The bag came open, and Trent's fascinated eyes saw the German's hand close on the silencer gun. Schill was about to lift it from the bag when with a hasty rap at the door Kurt reappeared.

"I couldn't help it," he whined, meeting Schill's angry gaze. "The hotel detective got suspicious of me and I had to wait."

"What of the police?" snarled the killer.

"No sign of them—"

"Gut! We'll march these two into that rear hall." Schill lifted the gun with the silencer. "Lift your hands!"

Trent pressed his left elbow tight against his side and swiftly raised his hands. There was a flash, a hiss of steel, and the dagger he had hurled buried itself in Schill's throat. With a terrible gasping sound, the Gestapo man slid to the floor.

FOR ONE fateful second, Kurt stood paralyzed with horror. Trent swung a jolting left to the man's jaw, Kurt's head snapped back, and he crumpled in a grotesque heap.

"Good Heaven!" Crabb said in an awed voice. "That knife—where did it come from?"

"Out of my sleeve," Trent told him. He looked down coolly at the dying Nazi. "I was afraid he'd see the hilt drop into my hand—the release-bulb on the harness worked a trifle too fast."

Crabb shivered, took his eyes away from Schill's body. "I'd already said my prayers. I still can't believe I'm alive."

"You can pinch yourself on the way to the roof. We've a tough job if we're to head off Mannrich and those phoney Canadians!"

"Wait! Why not phone General Busby?" Crabb said as they reached the hall.

"At the rate Mannrich and Woring are probably driving, they could be clear to Anacostia, and it's not much farther to Bolling Field. I just remembered that Mannrich would have a diplomatic license-tag and the cops can't stop him for speeding. Busby would probably be out on the field, and even if we got him he wouldn't believe us. One of those Nazi devils might intercept the message and they'd race off without even waiting for Mannrich and Woring."

Crabb panted after him up the service stairs.

"You're right, Eric, it's up to us! If Hitler gets those bombers, he can raid convoys halfway across the Atlantic."

"That's only a small part of it. Remember that tracing? Those red circles are bomb-targets in Washington!"

"What?" groaned Crabb.

"I'll tell you the rest in a minute." They had come out on the roof, near the waiting gyro. They climbed in and Trent quickly switched on the starter. The warm engine caught, backfired with a loud report. A window in an office building across the street slid up and a man looked out. As he saw the gyro, he ran back into the office.

"As if we didn't have enough trouble," Trent said ironically. "There he goes, calling the cops—I suppose the story of the 'gyro killers' is on every radio station."

The engine sputtered, changed to a smooth roar. Trent jumped the ship clear of the roof, swung it straight across the city.

"Are you sure—about their bomb-

ing Washington?" Crabb said anxiously.

"Not much doubt. I should have guessed it before—that story about their carrying bombs in hopes of seeing German raiders was undoubtedly framed up by Mannrich. Busby would never question it since it came from the British Embassy."

"Lord help the capital if those bombers get off," Crabb said grimly. "They could tie up Washington for weeks, until the buildings were rebuilt."

"It's worse than that, Mort. They're planning to paralyze the Government. That first red circle was for Bolling Field, but it's only a starter. They'd drop one or two eggs there and maybe a couple on Naval Air, then go on to the Navy Yard. From there that dotted red line led to the Capitol."

"Congress!" exclaimed Crabb. "They're having night sessions! I just remembered!"

"The Nazis must have figured on that." Trent stared over the side of the gyro. "If I've got that red course-line straight in my mind, the White House is one of their main targets. They could come straight down Pennsylvania Avenue, with all those lights, and pick off whatever they wanted—Department of Justice, with all its spy-records, Treasury, State-War-Navy, and a dozen others. With Naval Air and Bolling crippled, they'd never get enough fighters in the air to do any good, even if they had time. And when those butchers got through, they'd simply make a dash for the Atlantic and get away."

"Look—they're turning on the floods at Bolling!" interjected Crabb.

Trent peered out over the cowl. "That's a P-40 hangar. Mort, those babies are coming after us!"

He sent the gyro up steeply into the clouds, until he could hardly see the ground through the mists. Then he headed at top speed across Anacostia Hill and the asylum at the top. As the gyro descended toward Bolling, its engine idling, he spied a car racing around the side of a hangar toward the first of the six Consolidated bombers.

"Mort, they've made it! That's Mannrich and Woring!"

THE LIBERATOR crews were gathered in a group near the leading ship. They swarmed around the car, then turned and hurried toward the big bombers. Trent threw the gyro into as steep a dive as it would take. Abruptly, a searchlight blazed on, lifted toward them. He plunged the gyro down through the beam, leveled off a hundred feet above the staring crowd of Air Corps men.

"Busby!" he shouted. "Grab those Canadians. They're Nazi spies—they're going to bomb hell out of Washington!"

"You madman!" howled Busby. "Land and give yourself up, or I'll have you shot down!"

"Search Smythe!" Trent yelled
(Continued on page 64)

(in 4 to 14 months)
THIS TRAINING places YOU IN AVIATION



**Master Mechanics
IN 1 YEAR**



**Aeronautical Engineering
IN 14 MONTHS**



**Aircraft Drafting
IN 4 MONTHS**



**Production Mechanics
IN 4 MONTHS**

WE CAN'T SUPPLY THE DEMAND FOR OUR GRADUATES

"I am a California Flyers Graduate." It means something to say that. It means that aviation wants you to the extent that over 96% of all California Flyers graduates are employed in the industry and that it is impossible to supply the demand for our graduates. It is a passport into aviation. Secondly, it means that you are a man marked to succeed like the California Flyers graduates before you. And that is what *really* counts.

Why does a California Flyers man stand so high? It is obvious once you have heard the complete story of this famous school. Its founders believe that aviation should be taught in a school where the student remained an individual—learning aviation as it pertains to his individual ambitions and qualifications, and by so doing preparing *him* for the responsibilities of leadership. This way the graduate is prepared to meet today's aviation problems and to contribute to tomorrow's aviation advancement. This is the way today's leaders learned. Only this way can a training program be built for the industry, on industry's specifications. They believe too, that the entire field of aeronautics—engineering, mechanics and piloting are all closely interwoven and that a student should train in a school that teaches all of these important divisions. Above all, they believe that aviation should be taught in an environment of aviation activity, taught where the greatest aviation developments originate, taught where there is the greatest number of men actively engaged in aviation. This is why California Flyers is located in the heart of the world's aviation capital on the world's busiest testing field.

If this is the kind of school that you would like . . . friendly, efficient, modern and thorough; an aeronautical school operated by practical aviation men, you will be most interested in reading the *complete* story of California Flyers in the new 64-page catalog which tells today's story of aviation at work, complete details of the training courses and just what it takes to be a *California Flyers man*.

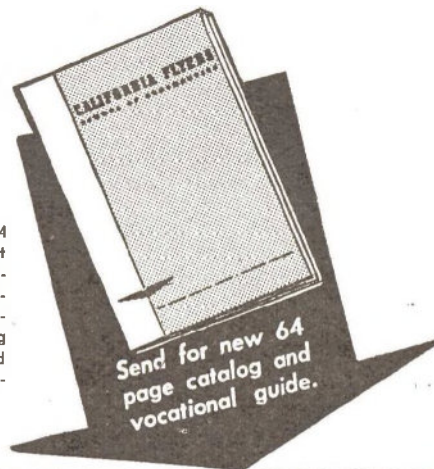

• Write for new 64 page catalog, get complete information on all of California Flyers' aviation training courses, tuition and employment opportunities.



LEARN ABOUT THIS COMPLETE RANGE OF PRACTICAL CAREER COURSES

- CALIFORNIA FLYERS, INC., School of Aeronautics, Dept. F.A.-6
 Los Angeles Municipal Airport, Inglewood, California
- Please send me your catalog and complete information on training, tuition, living conditions and employment opportunities. I am over 16 and interested in the subjects, checked:
- Aeronautical Engineering
 - Production Mechanics (Aircraft sheet metal)
 - Instrument and Radio Beam Flying
 - Instrument Technician
 - Airline Piloting
 - Aircraft Drafting
 - Master Mechanics

Name _____ Age _____
 Address _____
 City _____ State _____

Approved by the Civil Aeronautics Authority of the United States Government for Flight and Ground and Master Mechanics Courses.

back. "He's got the targets marked on—"

A roar from one of the first bomber's engines drowned the rest of his warning. Busby whirled, and in the glare of the floodlights Trent could see the alarm on his pompous face. He ran toward the first Liberator, just as Mannrich and Woring scrambled in behind the crew. Mannrich twisted around, fired a hastily-aimed shot, and Busby's hat flopped from his head. Two more of the Liberator's engines roared and the huge ship lunged out from the line, scattering the crowd.

Army men were rushing toward the other Liberators, and as Trent gunned the gyro after the first bomber he saw the prop of a P-40 whirl into life. He swooped over the fleeing ship, pitched a quick burst at the pilots' compartment. The front-gunner frantically spun his mount and hurled a fiery blast at the gyro. Trent flung his ship toward the ground.

"Get ready with the smoke Mort!" he shouted. "Give 'em all you've got!"

The Liberator's fourth motor was now revving up, and the bomber surged ahead under full power. Trent lifted the gyro in a dizzy climb, then charged down straight into the big ship's path. The Liberator was off, climbing fast, as the gyro dropped in front of it. Black smoke suddenly eddied from the gyro's tail, a split-second before the nose-gunner opened fire. Tracers flamed through the smoke-screen and the Nazi's bullets clipped the top of Trent's enclosure.

Crabb's swiveled .30-.30 hammered out three short bursts, as he aimed in the general direction of the Liberator's nose. The big bomber skidded in a wild turn. Trent dropped the gyro underneath, came up in a crazy zoom on the other side. Another cloud of dense black smoke spread back and hid the bomber's nose. Beyond, Trent could see five or six P-40's streaking in.

One more desperate fusillade from the blinded nose-gunner probed wildly through the smoke. A rotor-blade gave a dull zing as a bullet nicked it, and the remains of the cockpit enclosure collapsed. The black smoke was starting to thin out when the P-40's closed in, above and behind the bomber. Trent hoisted the gyro out of the way with a neat climbing turn, watched the red fangs of the fighters' guns crisscross in front of the stolen ship. The Liberator's lights flashed on and off frantically in token of surrender.

Trent drew a deep breath, clawed pieces of Plexiglas out of his hair. "Mort, I never thought I'd see the day when I'd deliberately get in front of somebody's guns. What do you say we go back and make old Busby eat humble pie?"

"NOW, TRENT," General Busby said pleadingly, "you won't give this story to the newspapers, will you? No need to make a fool of the Army—undermine public confidence."

(Continued on page 66)

Aero Book Reviews

Any volume described in this department may be obtained, at the price quoted, direct from the publisher named and at the address given. When writing for a book kindly mention that you saw it reviewed in FLYING ACES.

Naval Training

Dive Bomber, by Ensign Robert A. Winston, Holiday House, 225 Varick St., New York City, \$2.00.

Scores of books have been written concerning flight training in the Army Air Corps, taking the reader through Randolph and Kelly Fields, but this is the first time your reviewer has seen a volume dealing with Naval training.

Like thousands of other young men, Mr. Winston was head over heels in love with aviation and wanted to get into the game instead of merely being an outsider. Therefore, he gave up an excellent position in the midst of the depression and went to an elimination base to see if he had what it took. He passed, of course, else this particular book would not be on sale.

After those first hectic days at the elimination base, Winston went to Pensacola as a Flight Cadet. While there, he had numerous experiences that are well worth setting forth, and he explains the Naval training system and service life very vividly.

Winston liked the huge flying boats—Big Boats, he calls them—and was all set to choose that branch of service—and then he flew fighters! His description of this latter type—how they flew and handled—is really heart-warming. Naturally, at the end of his course he asked to be assigned to single-seaters. And from there on, the book becomes even more readable, if that is possible.

As we've suggested in connection with other books, beg, borrow, or steal—but don't miss *Dive Bomber*.

Advanced Procedure Handbook

Procedure Handbook for Aircraft Stress Analysis, The Aviation Press, 580 Market Street, San Francisco, Calif., \$4.00.

Our readers who know the class of material being published by this firm will realize that in the *Procedure Handbook for Aircraft Stress Analysis* they have really gone to town on a valuable aeronautical engineering handbook. It has been written and compiled by those three ace engineering writers—Nye, Hamilton, and Eames—who have already made great names for themselves with other Aviation Press volumes.

This book is bound with the

popular steel spiral which fits modern conditions so well, and it contains many fine plates, illustrations, charts, and analysis reports. It attempts to present as simple a treatment as possible on the subjects of strength of materials and stress analysis applied to the airplane as we know it today.

The chapters include details on aircraft design specifications, material for aircraft construction, testing of materials, a very complete review of mathematics, and another on applied mechanics. There are several theory chapters devoted to shell-type structures, joints, beam components, compression members and columns, and a special section on the graphical analysis of structures. To attempt to offer a detailed criticism of this book is impossible unless one be a full fledged aeronautical engineer. But even the most cursory examination of the book will show that it is a "must" for any student of aeronautical engineering. It is well done, well produced, and profusely illustrated with charts, sketches, and photographs.

May 10, 1940

Juggernaut Over Holland, by E. N. van Kleffens, Columbia University Press, 2960 Broadway, New York City, \$2.00.

E. N. van Kleffens, Minister of Foreign Affairs for the Netherlands, has done an excellent job with this book. As an official of Holland's government before the German invasion in May, 1940, he was able to obtain many "inside" facts which are set forth in *Juggernaut Over Holland*.

He tells how the Germans, while trying to convince the Netherlands' people of their good faith in that country's neutrality, were at the same time carrying out undercover work in preparation for invasion of Holland. And when the actual hostilities came, the Dutch army held up the Germans for five full days, whereas the Nazis expected to completely conquer that country in the short space of one day, according to the author. That heroic resistance gave Britain and France needed time to prepare their armed forces to resist the onward thrust of Hitler's troops.

It is indeed fortunate that Mr. van Kleffens was able to escape from Holland before that country was completely subjugated. Otherwise, this fine volume would probably have never been written. It is heartily recommended for all who are interested in the political phenagling that went on behind the scenes early in 1939, and for others who are merely interested in warfare as a whole.

(Also see pages 72 and 78 for other reviews)

For Top Value, Top Looks and Top Performance PLUS—Get

CLEVELAND MASTER MODELS

"America's FIRST LINE of Flying Models"

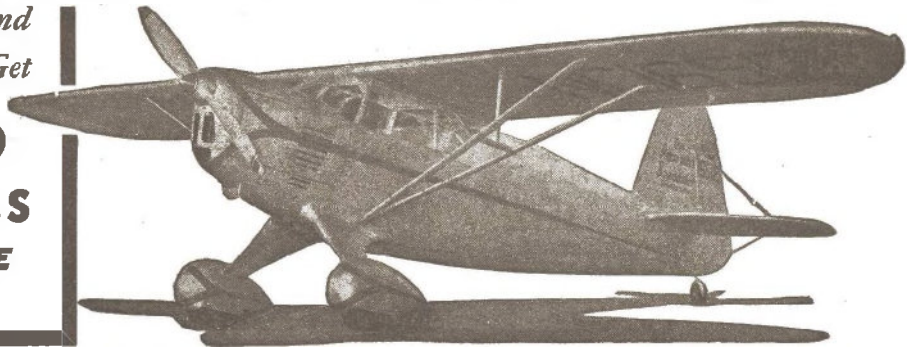

Big 82" Authentic 3/4" Scale STINSON RELIANT

America's most popular radio-controlled design. A realistic miniature of a model known and seen at almost every American airport. Spacious interior for experimental equipment, such as radio receiver, etc. Shock absorbing landing gear fitted with pneumatic wheels and balsa shoes supplied partly finished. A masterpiece of gas model beauty and completeness. Complete Kit GP66 (except power unit) only **\$10.95**



The Popular FLEETSTER

Span 42 1/2". Class "B" contests. A big hit in looks and contests. Complete Kit GP-5007 (except power unit) only **\$2.50**



GP5005 48" CHAMPION Class "B" Gas \$2.95

REARWIN SPEEDSTER

Called most beautiful scale job on the market. Complete Kit GP-69 (except power unit) only **\$7.50**



AMERICA'S Most Famous GAS MODEL SERIES

The Record Breaking PLAYBOY, SR.

This is one of the most astonishing gas model performers yet developed. In meet after meet it has broken records, carried off prizes and honors. Be sure to feature it. Huge 80" span. Beautiful flights. The talk of the model world. Kit GP-5017 (complete except power unit) only **\$3.95**



GP5020-48" Viking Class "A" or "B" Gas **\$1.50**



GP5004-50" Cloudster. Class "B" Gas. **\$2.50**



ES014 36" THERMALIER Class "C" Stick 50c



GP5016 33" ITSY BITSY Class "A" Gas \$1.00



CLEVELAND SKOOTERBUG
First commercially produced microfilm job. Perfect Class A R.O.G. model. Capable of many minutes indoor flights. Complete Kit E-5012, only **25c**.

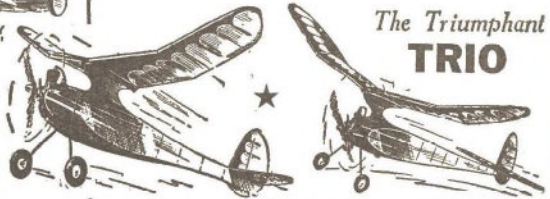

The Triumphant TRIO

Other PLAYBOY Gas Models

46" Playboy Jr. (left) Kit GP-5006 (complete except power unit) **\$2.50**
88" Baby Playboy (right) Kit GP-5008 (complete except power unit) **1.00**

Super Values in Gliders!



7 FT. SPAN
BIG!
CLEVELAND CONDOR Soaring Glider. Span **\$1.00**
34". Class D or E. Complete Kit E-5019
CLEVELAND EAGLET Soaring Glider, Span **50c**
48". Class C. Complete Kit E-5018

SKYROCKET

Big 8 1/2" scale job of America's new twin motor 450 m.p.h. "Terror of the Skies." Fast flyer with both motors pulling. Yellow and blue. Complete Kit SF-75, only **\$3.00**

SPITFIRE

Beautiful 27 1/2" scale model of England's popular interceptor fighter. Large wing area assures excellent flying. All silver (with suggestions for green and brown camouflage). Complete Kit SF-73, only **\$2.50**

The Pride of the R.A.F.

AIRACOBRA

25 1/2" scale model of America's amazing "cannon-plane" standard pursuit interceptor. High speed flyer. All silver. Complete Kit SF-76, only **\$2.50**



CONTEST WINNING CURTISS F11C-2
Complete Kit SF-49 (Span 23 1/2") **\$2.50**
Complete Dry Kit D-49 (Span 15 1/4") **85c**

"CLEVELAND Models Win More Compliments, Prizes and Honors Than Any Other Line of Models in the World."



42 3/8" DOUGLAS TRANSPORT

A Beautiful Kit. Complete with Liquids. Kit D-55. **\$2.50**

MESSERSCHMITT Me-109



Fast flying 24 1/2" scale model of Germany's "shark" fighter. Black and white. Complete Kit SF-74, only **\$2.50**



CURTISS HAWK P6-E
Span 23 1/2". Dry Kit SF-21, formerly \$2.50 now **\$2.25**

New Catalog of "America's FIRST LINE of Models"

Every model airplane builder should have it. This new Cleveland Catalog No. 32 features all the famous Cleveland authentic scale models (including the 4 New War Models), contest models, gas models, Nature models, gliders, etc., etc., for indoor and outdoor flying. Prices 25c up. Send for your copy NOW. It's only **5c**

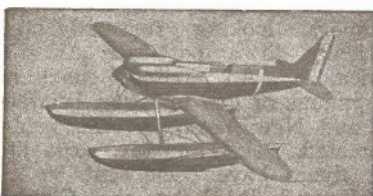

Well Loved Supermarine S.6.B
Complete Kit SF-19 (Span 22") **\$1.75**
Complete Kit D-19 (Span 14 1/2") **.65**

ORDERING INSTRUCTIONS Send check or money order—cash at your own risk. Include 15c for packing charge on orders under \$1.50. Shipments outside U. S. add 10%—if over \$10.00 no additional charge. For P.P. Special Delivery in U. S.—Add 25c. "Same Day Service." Let us prove it.

CLEVELAND MODEL & SUPPLY CO., INC.

"America's FIRST LINE of Models"

4509A52 Lorain Avenue, Cleveland, Ohio, U. S. A.

"Tell you what," said Trent amiably, "you let us keep Leaping Lena and we'll call it square. That is, providing you call off the cops you put on our trail."

Busby mopped his forehead. "Take the gyro—we don't want it, and it's a cinch the Germans won't claim it. I've already explained to the police. The whole thing was a diabolical plot. This Mannrich has been impersonating Smythe for two months, but he didn't know the full circumstances about that Brussels thing. When he found that there were four people who'd swear that Smythe was dead, he got the jitters. On top of that, some news photographer snapped a picture of him at a British Embassy function, and it was due to come out

in next Sunday's rotogravure. So he got his Gestapo unit into action, to wipe out the four of you. He'd intended to stay on in Washington when the original plan was merely to steal the ships. Then, when they switched to the bombing plot, he decided to fly back to Germany with them.

"He squealed on Woring, too. Woring faked a forced landing with the Liberator that was bringing the real Canadian pilots, and dropped in at an isolated field in New York State. Nazis with machine guns captured the Canadians, took their uniforms—and you know the rest. We've flashed word to the New York police to arrest the Germans they left on guard and turn the pilots loose."

"Let's hope they give them some clothes first," Trent observed. "Unless you're trying to add insult to injury."

Busby let out a bellowing laugh. "It wasn't that funny," Mortimer Crabb said gloomily. "In fact, it wasn't funny at all."

"He's just trying to keep me happy," said Trent. "It's all right, General. I won't expose you. But don't forget about that smoke-screen gadget of Mort's. If that wasn't a perfect demonstration, I never saw one."

"He'll get the contract, don't worry," Busby assured him.

"Well, I guess we'll be jumping off," said Trent. "Now that we've got Leaping Lena, though, we'll drop in on you one of these days."

"Wait a second," interrupted Busby. "How can I get in touch with you?"

"Sorry," said Trent, with a chuckle, "I keep my telephone number confidential."

Mortimer Crabb snorted.

"Confidential my eye! Just ask the nearest blonde."

THE END

The Airmail Pals

HOWDY, all you A.P.'s! This office looked just like a clearing house the other day when your R.H.P.D. was suddenly flooded with a load of post-New Year mail. So we decided to exchange notes immediately before the pile became desk high. Yes, letters from all over! Australia, New Zealand, Canada, Mexico, and many places in the U.S. It was a great day for you missive makers, especially those who wanted foreign pen pals. A goodly portion of the week's incoming mail came from far off places—which should delight you foreign pen pal seekers.

After sifting the mail here and there, we finally picked out the three-view prize winning note of the month—the one that told best the interesting goings-on between pen pals. And that one was penned by Sidney Ralph, of Athens, Ohio. Sid says:

"Through your A.P. set-up I was able to make contact with a young chap up in Jarvis, Ontario, Canada. I've been always interested in the activity of the Canadian Royal Air Force, and when I asked for a fellow up in Canada, preferably near a military drome, you connected me with young Dick Jepson. And luckily, Dick is within walking distance of a

Bombing and Gunnery school.

"He tells me they are very strict up there with visitors and no cameras are allowed unless special permission is granted. Anyway, he was able to send me photographs of the Fairey Battles as they zoomed above his housetop on the return trip from bombing practice over Lake Ontario. He tells me several of his friends are ground crew members and there is a great percentage of Yankee volunteers serving as Flying Officers.

"Dick is very much interested in U.S. military planes and through a friend of mine (also met through Airmail Pals), living in Dayton, we are able to carry on quite a bit of a picture-news service. So thanks, R.H.P.D., for helping me make these valuable contacts. And now before I close, I would like very much for you to give me the address of a chap out on the West Coast where all this aero activity is buzzing night and day."

No sooner said than done, Sid. We're teaming you right up with another fellow your age who lives within a stone throw of Ryan out in San Diego. Now you two A.P.'s can do the rest. And, of course, Sid, your set of three-views are on their way to you airmail right now.

—THE R.H.P.D.

SLIPSTREAM

(Continued from page 32)

instrument which tells skyfighters how many rounds of ammo they have left. . . . The War Department is building the world's champion runway at Wright Field—a take-off stretch nearly two miles long. Part of it will be graded for experimentation with down-hill hop-offs. . . . According to Ordnance Expert Frank Newton, of Fort Rosecrans, his new vacuum muffler will not only silence a plane but also increase its horsepower. . . . "Lightups" would replace blackouts as a means to confuse sky raiders, if British Aero Writer N. Pemperton-Billing's scheme gets a play. He suggests blinding night invaders with brilliant beams. . . . Remington Rand has submitted a gadget to the Government said to promise a 50 per cent improvement in U.S. bomb-sight accuracy. Judging by the accuracy already claimed for our bomb-sight, that should make it 6,574 per cent perfect.

Thisa and Thata

They say the Japs are asking Adolf H. for 1,500 Nazi fighting planes and skymen in case of a new war in the Pacific. . . . Britain has bought "Old 301," the very first DC-2 airliner. . . . Italy's turned out a special four-engined transocean transport, looking forward optimistically to a post-war Atlantic service. . . . An airliner consumes 390 gallons of gas in a run between Chi and New York, in case you're interested. . . . Thus far, some 550 U.S. flyers have been sent to the RCAF and RAF by the Clayton Knight Committee, which hopes to enroll another 600 before closing its

HOW TO GET AN AIRMAIL PAL

FIRST, write the best possible letter you know how. Use your best pen-and-ink handwriting or a typewriter. In your letter, introduce yourself fully—for this is the letter we'll forward to the pal we'll pick out for you. Tell your age, your interests in aviation, your other hobbies, and any additional items that might interest a new friend.

Then on a separate sheet tell the Right Honorable Pal Distributor what kind of an Airmail Pal you want. Send your letters to Airmails Pals, FLYING ACES, 67 West 44th St., New York, N. Y. Be sure to enclose a stamped, self-addressed return envelope, plus five cents in stamps or coin for each pal requested (our fee for the R.H.P.D.'s "Kitty"). We'll try to supply you with a pal in line with your specifications, although we cannot guarantee to fill the bill exactly every time.

Your new pal's letter will be sent to you, and yours to him—after which you will correspond direct.

Do not ask for "lists" of pals. We cannot supply them.

Regarding foreign pen pals please note that because of the present European war we cannot supply foreign pen pals in all cases. However, we will fill as many requests as possible, then when the supply runs short we will substitute domestic pen pals.

If you are an American resident and want an overseas pen pal, do not write a pen pal letter. Instead, send us a short note telling in a general way what kind of a chap you are and what kind of a pal you seek. Enclose a stamped, self-addressed return envelope and five cents for each pal called for. A foreign writer's letter will be sent to you, then you may correspond with him direct.

If you live outside of the United States and want an American pen pal, write a complete letter as described in the first paragraph of this box, and send it without the return envelope but with an International Reply Coupon worth five cents. Get the coupon from your local postoffice. Your letter will be forwarded to an American correspondent, after which you need only wait for his reply.

PLANE TALK

SKYWAY

SAVINGS ON ALL SUPPLIES

SPECIAL!

Complete outfit—latest Syncro B30 or Sky Chief motor—and your choice of any \$2.95 kit, all for only **\$9.90** P. P.

We Sell all kits, gas motors, supplies.

<p>10" Balsa Strips Select, Hard Stock</p> <p>1/16 sq. 60, 50 1/18x3/4 85 for 50 1/18x2 18, 50 1/18x3 15 for 50 8/32 sq. 30, 50 3/8 sq. 30 for 50 3/8x1/8 12 for 50 3/8x1/4 10 for 50 3/16 sq. 8, 50 3/8 sq. 6 for 50 3/8x1/2 3 for 50</p> <p>18" Balsa Sheets</p> <p>1/84x2 6 for 10c 1/32x2 9 for 10c 1/16x2 8 for 10c 3/32x2 7 for 10c 3/8x2 .8 for 10c 3/16x2 8 for 8c 3/8x2 .3 for 9c 3/8x2 .2 for 11c 3/8 & 30" cost twice 18" 3x50, 4 times</p> <p>NOSE BLOCKS</p> <p>1x2x11c 2x2x12c 2x3x18c 3x3x14c 3x3x27c 3x3x39c 5x3x317c</p>	<p>5 FOOT Balsa Minimum 50c</p> <p>3/4x3/16 10 20c 3/4x1/410 20c 3/16 sq. .8 20c 3/4 sq.6 20c 3/4x1/23 20c 3/8 sq.2 20c 3/8 sq.2 20c</p> <p>Sheets, 4 times 18". Double the above price for genuine aircraft SPRUCE</p> <p>18" Balsa Planks</p> <p>3/4x1/2 .2 for 5c 1x11 for 5c 1x21 for 9c 2x21 for 16c 2x31 for 22c 2x61 for 42c 3x61 for 72c</p> <p>Plastic Blocks</p> <p>4 oz. 25c, 1 oz. 10c</p> <p>PROP. BLOCKS</p> <p>1/2 x 1/2 x 5 7-8c 3/4 x 1/2 x 6 6-8c 1/2 x 1/2 x 8 8-8c 3/4 x 1/2 x 10 2-6c 3/4 x 1/2 x 12 8c ea. 1 x 1 1/2 x 12 6c ea. 1 x 1 1/2 x 15 6c ea. 1/16 1/4 40c ft.</p>	<p>SKYWAY GAS MOTORS No Premiums or Packing Charges on Motors—P.P. 15c</p> <p>Ohlson "19"\$14.50 Ohlson "23"16.50 Ohlson "60"21.50 Forster \$17.75 Ball Bearing 19.50 New Forster "29" Class B 16.75 "O.K." Special15.50 "O.K." Twin, for radio con. 40.00 Dennymite \$12.85 Unit 15.85 Brown D \$1.50 Brownie \$7.50 New Brown "B" Now16.50 New Super Atom15.50 Mighty Midget \$8.50 Gwin 12.00 Tiger Aero16.50 Synchro B-30 \$7.95 PC-2 Kit 4.95 Sky Chief6.95 Perky10.95</p> <p>Big Allowance for Old Motors!</p> <p>CEMENT CLEAR DOPE THINNER Banana Oil 1 oz. 5c, 1/2 pt. 30c 2 oz. 10c, pint 50c Colored Dope 1 oz. 6c, 2 oz. 11c 1/2 pt. 35c, pt. 60c</p> <p>AA TISSUE All col., doz. 19c Silver4c Supersilk, wh. 5c</p> <p>RUBBER LUBE WOOD FILLER Liquid Celluloid 1 oz. 9c, 2 oz. 15c</p> <p>G. M. SILKSPAN White, Red, Gel. Low, Orange, Blue 3 for 25c.—"00" —3c per sheet.</p> <p>Gas Model Silk Hvy qual. 45c yd. AA TISSUE All col., doz. 19c Silver4c Supersilk, wh. 5c</p> <p>Bamboo Paper White 5c, 6 for 25c Colors, 2 for 15c</p>	<p>Trexler Wheels</p> <p>1 1/4, 1 1/2—40c 1 3/4, 2—50c 2 1/4, 2 1/2—60c Gas. Mod. 2 1/2—\$1 3-1.25—3 1/2—1.50 4 1/2—1.75</p> <p>M & M WHEELS</p> <p>1 1/4, 1 1/2—50c 1 3/4, 2, 2 1/2—60c Gas Mod. 2 1/2 90c Flyweight75c NEW 3" —\$1.00 3 1/4 1.50, 3 1/2 2.75, 4 1/2 2.75, 5" 4.00</p> <p>PROPELLERS</p> <p>Balsa Paulo Ritz Wing Gas 5" 4c-7c Mod. 6" 5c 9c 8" 35c 7" 6c-12c 8" 35c 8" 7c-10c 10" 35c 9" 8c-19c 11" 35c 10" 9c-22c 12" 35c 12" 10c-28c 13" 35c 14" 12c-40c 14" 35c 15" 15c-50c 15" X 16" 16c-X 18" 50c 18" 25c-X 18" 50c</p>	<p>GAS MODEL ACCESSORIES</p> <p>Champion Spark Plugs 3/4 or 1/2 50c Condensers—Metal, 15c Smith. 25c Plugs & Jacks, Set of 2-35c val. 25c Midget Tip Jacks 25c val. 2-15c Terminal Clips 5/8" 10c val. 4-5c Gas Funnel, Alum. strainer. 25c Spaghetti Tubing 3/16" 3 ft.—10c Toggle Switch 50c val.25c "3 to 1" SAE 70 oil—1/2 pt.25c 12" High Tension Leads—Best. 14c Booster Leads—50c val.35c Masking tape—1/2x36-Instruc. card 5c Alligator Clips—5c Solderless. 10c Xist Manifold—Keep Ship Clean Nickel plated 50c. Streamlined \$1.00 Spark Plug Wrenches—any size. 20c Neoprene Tubing 1 ft.15c</p> <p>VOIT WHEELS</p> <p>3 1/2 1.50, 4 1/2 1.75 Race Car Set 6.00 Ball Bearing 8.00</p> <p>COILS</p> <p>Smith—3V. \$2.50 Competitor 1.75 Superlite 1.75 Powerhouse 1.50 Aero Coil 2.25 Brown Jr. 1.75 U. S.1.00 Wing & Tail Lts. (3 in a set) 5/16, 8c 9/16, 10c 11/16 12c per set</p> <p>TIMERS</p> <p>Austin\$1.00 Dural1.95</p> <p>ALUM. LEAF 3 sheets 5c</p> <p>BONA FIDE DEALERS Write for WHOLESALE PRICE LIST</p>	<p>RUBBER-POWERED ACCESSORIES</p> <p>Model Knife, Surgical Steel Blade 10c Model Pins 1/2 or 3/4 100 for ... 5c Sheet Celluloid 5x7 3c, 14x17. 15c Ball Bearing Washer 10c value. 5c Sandpaper, 12 sheets, 5x5.7c Liliput Lights—for display, 3 lamps, wired, instruc. sheet, per set 60c Insignia 36—American, French, English, German, Squadron, in colors, gummed, per sheet. 5c Washers, pinhole. 1/4, 3/4, 2 doz. 5c Nose Plugs for 5c; 3/2"—8c, 3/4"—6c, 1" 4c.</p> <p>MUSIC WIRE</p> <p>.014 6 ft. .2c .020 .028 6 ft. .3c .034 .046 0 ft. .6c .0496 ft. .8c 1/16"3 ft. 8c 3/32"5 ft. 15c 3/16"5 ft. 20c</p> <p>BROWN RUB'R</p> <p>1/16 sq. 15 ft. 5c 3/8 Hat. 15 ft. 5c 3/16 Hat. 32 ft. 5c Skola 225 ft. 1/16 50c, 3/4— 60c, 3/16—85c</p> <p>Camel H'r Brush Med. 5c, Lge. 8c S'n. Jc. Gas Mod. 15c</p> <p>Thrust Bearings</p> <p>1/2 doz., Sm. 5c 1/2 doz., Lge. 7c Celluloid Radial</p> <p>ENGINES</p> <p>1 1/2" 8c, 2" 12c 2 1/2" 14c, 3" 17c 4" 50c, 4 1/2" 65c</p> <p>MACHINE GUNS</p> <p>3 1/2" 2c, 1 1/4" 4c 1 1/4" Lewis. .50 1 1/4" Lewis. .60 1 1/4" Ring Mt. 10c 1 1/4" Ring Mt. 15c</p>
---	--	---	---	--	--

FREE With all purchases over \$1.00 your choice of: (1) Model Water Sprayer. (2) Model Builder's Knife. (3) Choice of 2-30" Model Plans—Curves, Weather, Boating, Driggs, Balanca. (4) Masking Tape. (5) 6 sheets AA Tissue. (7) Sandpaper 12 sheets.

SHIPPING INSTRUCTIONS: Packing cost on all orders 10c. 38" or 5 ft. 20c. To packing cost add 15% postage for U.S. possessions, Canada, foreign countries when order is over \$1 and 15c if under \$1. 5 ft. packages to Canada shipped Express Collect. Minimum order, 50c.

POSTAGE ON ALL U. S. A. ORDERS.

SKYWAY MODEL AIRCRAFT SUPPLY CO., 426 SIXTH AVE., DEPT. F, BROOKLYN, N. Y.

books. . . . New York's 57th Street Allerton House boasts of having Manhattan's first hotel air-raid shelter. . . . So many Curtiss and Bell workers in Buffalo had never seen the finished products of their handicraft that the companies recently held an airport field day and showed 'em a few military jobs. . . . New Zealand now has an Air Force Cadet Corps

for lads between the ages of 16 1/2 and 18.

Tailwind Tip-Offs

Reporting 41 prop accidents during 1939-40, all serious or fatal, the CAB offers this pointed flying field axiom: "Propellers were made to lift wings—not mortality rates!" . . . Huge new-type land planes are being

made for PAA's Atlantic service, but Prexy Trippe won't say yet who's making 'em. . . . The CAA is installing 10 U-H-F (ultra high frequency) aero radio stations between New York City and Chicago. Virtually static-less communications with airliners are promised in the near future.

THE END

IGNITION—HOW IT WORKS

(Continued from page 52)

causes the magnetism to rapidly die away. The secondary winding is affected by each of these changes in magnetic field strength. The core, however, loses magnetism more rapidly than it gains it. It is therefore the dying of the magnetism that has the greater effect on the secondary winding, causing it to produce a

sparking current.

To use this principle for ignition, the engine is fitted with a revolving switch, or circuit breaker, which closes the primary circuit as the piston is on the compression stroke and then breaks the circuit when spark is desired. To produce an intense sparking current, the circuit is broken as

abruptly as possible to cause the magnetism to die away suddenly. The condenser is used to prevent a return path for the high currents in case of foul.

The function of the condenser is to suppress the "make" and to enhance the "brake" so that the induced high tension spark in the secondary winding occurs without a spark at the contact points at the "break." Otherwise, the platinum contacts would be rapidly burnt out.

THE END

FLYING ACES CLUB NEWS

(Continued from page 39)

and he lives in Fairfield, Iowa. Some time ago Don wrote and told us of the difficult time he and his club members were having trying to get the city administration to appropriate funds for establishing an airport. He hammered away on this subject for over a year in a column in one of the local papers. The column was published once a week and was called

The Torque of the Town.

Finally, after three years, an airport has been built with one hangar accommodating five light planes! As soon as weather permits, construction will begin on runways.

Grand work, Don. You have every right to feel proud of the part you played in finally getting this airport under way. As for your query about

sending in photos of models made from "Trail Blazer" plans for DSM consideration, the answer is yes. But why bother with that, Don, unless you want another medal? You see, old-timer, we're awarding you a DSM for the marvelous work you've done in this airport struggle! Congratulations for a fine job well done!

Now here we have a missive from W. G. Hamson, of 36 Wilson Road, Ely, Cardiff, England, asking that F. A. Clubsters living in his district contact him so that they may get together and chew the fat about F. A.

"Ham" also says that he hopes F. A. is as good now as it has been before. He hasn't seen a copy of the magazine since the War began, but let's hope this copy reaches him and that he will soon be able to resume his model building and F. A. activities.

A note from Ervin W. Harrison, a cadet at the Culver Military Academy, Culver, Ind., brings out a ques-

tion which we are sure many other Clubsters would also like to see answered. Ervin wants to know whether he can send for his Cadet, Pilot, and Ace's star all at the same time? Yes, it's okay with Headquarters, Erv; there are no restrictions against saving up coupons and requesting all the badges at the same time.

Erv also swears that the ship he's now building is turning out to be a real DSM winner, and as far as he's concerned he's out to get that medal. As he puts it, "You know how much a medal means to a guy in uniform."

Well, boys, this ends the session. See you next month—same place, same time.

THE END

TABLE TOP AERODROME

(Continued from page 47)

tail production. Al invaded every five and dime in the city and bought up as many race cars, fire engines, and trucks he could carry. He got these just for their wheels.

The only tools used in building up his atomic aerial armada are a six-inch knife and a safety razor. Each exterior detail is checked for accuracy against his file of more than fifteen-hundred photos of war planes.

He often amuses his wife and baby by hanging up the tiny fighters with thin thread against the sky blue wall of his apartment and fixes them so that they're arranged in mock aerial combat. No one gets shot down in the battle of Kitchel-land, for he guards these gnatty fighters with the zealotry of a mother bear to her new born cub. Everything from a two- and a half-inch Nieuport 28 to a huge six-inch Handley Page bomber are represented in the conglomeration of British, French, German, Italian, and U. S. planes. Kitchel

knows the history of every one of these ships and performance figures, too.

He doesn't care much for the modern fighter or bombers. Too clean, he says. Not half as interesting as the old ones; no struts, wires, or gay colors of the flying circuses and escadrilles of 1914-1918.

TO DATE there are more than fifty ships in the collection and others are in the process of construction. The first model built was a replica of Eddie Rickenbacker's Spad. He has since made up models of "personal" ships for some of the leading war aces. But these ships are replaced to keep his international squadron up to full strength. Col. Harold E. Hartney, author of *Up and At 'Em* visited the aerodrome one day and went wild about the collection. He autographed Alan's copy of his book and said some very nice things about the collection. One ship that is a sure breath-taker

is a five-inch Curtiss JN4D-2, more affectionately known as Jenny. If you ever walked around a real Jenny, then you can appreciate Kitchel's effort in reproducing every single detail—especially the interplane bracing.

Kitchel's collection has already received some wide-spread publicity. When Universal Newsreel, for whom he works as a script writer, discovered a "genius" in their midst, they promptly decided to include his collection in a *Stranger Than Fiction* short. Several hundred feet of film showed Kitchel actually assembling one of the tiniest ships right up to the painting stage. The showing of the feature throughout the country brought him floods of mail from friends and model builders alike. Even a South American paper played up the mention of his curious hobby.

Kitchel values his collection at more than five-hundred dollars and has taken out insurance covering fire, theft, and damage. It was a good risk for the insurance company for they know he guards it with infinite care.

THE END

THAT CUBAN "GOOD-WILL" FLIGHT

(Continued from page 23)

Honduras, El Salvador, and Guatemala.

THEY ENTERED Mexico at Vera Cruz on January 14th and stopped at Tampico and Mexico City. On February 1st they crossed into the United States at Brownsville, Texas, and headed for Washington, D. C., via New Orleans and Atlanta. Following

an official reception at Washington, they continued on to New York City and landed at Floyd Bennett Field on February 6th. Then, after a program of receptions headed by the Honorable Cayetano de Suesada y Socarras, Cuban Consul in New York, they left on February 11th for Miami and Havana, arriving home on February 15th after an absence of just three

days more than four months.

American aviation observers who met the trio and who inspected their plane during their visit to New York City openly expressed admiration for the precision and skill with which the long flight was made. Mechanics at Wright-Caldwell Airport, Caldwell, N. J., who serviced the Wright Whirlwind engine before the flight, pointed out that the engine functioned flawlessly throughout the approximately 20,000-mile tour of the Western Hemisphere.

THE END

FATE FLIES THE BREDA

(Continued from page 29)

into the groups of puzzled natives. He knew something was wrong but he was not able to sense exactly what it was. The years he had been with Kirk—since that memorable day when they had both escaped from the zoo in Berlin where Kirk's father had been shot down in cold blood by German Intelligence officers—Tank had somehow been able to tune his intuition with that of Kirk.

This strange mental telepathy they had developed had often worked at the right time or when things seemed

the blackest. This time, though, Kirk was out cold and trussed up in an old closet and he was unable to fret and fume consciously.

Tank, however, continued to glance at the wreckage and then at the natives. He sensed that they were beginning to see the humorous or comical side to him and were openly amusing themselves at his expense.

Finally, he could stand it no longer. He suddenly let out a growl, moved like a panther, and grabbed one around the waist. He raised the un-

fortunate one high and then hurled him with terrific force into the scattering group ahead. Then with a bellow he started running rapidly for the village.

The natives ran before him and he waddled up the beach pathway with a pugnacious grimace on his broad mug. He sniffed and snorted aloud, then began to whine and gulp choking sobs as he entered the near end of the broad paved courtyard that ran between the two rows of native huts.

He stood there and stared about, uncertain just what move to make next. But he sniffed and picked up the trail of Kirk and started up the paved street. He was nearly half-way

up when the Dutch official came out of the carved entrance to his own quarters. Both Tank and van Gelder, as he was known, eyed each other across the distance that separated them.

Instinctively, Tank knew that since van Gelder was alone, something had happened to his Boss. The Dutch official drew a heavy gun from his holster and began to fire point-blank at Tank.

The ape, knowing only the theory of offense, crouched low and started for his enemy. Van Gelder fired three shots but they all missed at that distance. He saw the strange formidable creature approaching him and realized that he was not dealing with a cringing native. Tank lived up to his name and continued to lumber on, and at last van Gelder turned and retreated into the heavy piled building.

Tank did not change his stride, but his jungle instinct warned him not to approach directly. He skirted through a small building, picked up a chattering native, and hurled him out of the raised portion of one of the thatched round houses. The native screamed as he went out.

Tank blazed into the building, lumbered through a room, and then climbed out of a side window. He edged along a teak runway and clambered down a carved pole. He was in a side street now. In a minute he decided on his course and rumbled on through a lot of dank piles and disappeared under another building, all the time making his way toward the chieftain's place with a series of zigzags which offered cover and gave him time to rattle the mental matter.

Eventually, Tank reached the lower portion of the Dutch official's building and he moved like a jungle animal among the heavy timbers and through the maze of foundation uprights that had been woven into a supporting pattern. He waited for several seconds in the semi-darkness and sniffed again. He could hear voices and the thud of bare feet scurrying above.

He kicked off his rubber-soled sneakers, worked carefully up the side of the building, and reached a supporting member that ran under a series of screened windows. With a low growl he ripped them out with a quick, powerful movement of his paw and clambered up. He huddled there for a minute or so and then dropped inside silently. He waited and listened and sniffed.

Overhead, a new tone caught his ears and he went to the window again and saw several planes racing in from the north. They began to circle and come down lower and Tank was worldly wise enough to know that they meant more trouble.

THE ARRIVAL of the Japanese bombers brought new courage to van Gelder. He crept out of his small but solidly built office and peered about. He glanced over at the heavy

PHANTOM MOTORS

FOR PRICE... PERFORMANCE
DEPENDABILITY



- BULLET & TORPEDO CLASS "B" ENGINE FEATURES**
- New special heavy duty type radial motor mounting (replaceable plus standard beam mounting).
 - Special float type gas gauge (Torpedo only).
 - Newly designed larger sturdier gas tank made from Magnesium alloy.
 - Gas tank can be mounted on either side of the fire wall.
 - All motors equipped with the new Smith "Fire-Cracker" Coil.
 - Torpedo produces almost 1/5 horsepower with weight of 4 3/4 oz. Bullet produces almost 1/6 horsepower with weight of 4 3/4 oz.
 - Motors built to be used upright or inverted.
 - Your motor on its way 24 hours after order received.
 - Every motor power block tested in our factory and sold to you under a bonded factory guarantee.

WHERE can you get a model airplane motor which holds 3 world records; Altitude, Time in air, Air miles flown, for only \$7.25?

Is it any wonder that thousands of model fans have switched to Phantom. Phantom sells direct from the factory to you, cutting out all middleman profits. Phantom is built in the world's largest manufacturing plant for producing midget motors for model airplanes. Every motor is power tested before it leaves the factory, and is sold to you under a bonded factory guarantee. Don't delay! Clip the handy coupon below and we'll have your engine rocketing on its way to you in less than 24 hours after we receive your order.

PHANTOM MOTORS
800 East Gage Ave., Los Angeles, Calif.

Please RUSH the items checked below:

Money-order enclosed. Send C.O.D.

New improved 1941 Phantom "Bullet" complete with coil, tank and condenser - \$7.25

New Super Phantom "Torpedo" engine complete with coil, tank and condenser - \$10.95

Special 1 1/2 in. hardwood propeller - \$0.49

Miss Tiny Kit, Propeller and Phantom Built "Bullet" \$11.95

Add 3% if delivery point is in California.
Prices Slightly Higher in Foreign Countries

NAME.....
ADDRESS.....
CITY.....
STATE.....

F-17



closet door that shielded his captive and then risked going out to the veranda of his compound house. He watched the planes circling for their landings along the beach and then decided to maintain the dignity of his office and await the arrival of the men who had come at his request. He sent a native orderly down to present his compliments and his official invitation to visit him at his official residence.

He was very satisfied with himself and lit a long cheroot and poured a drink. He rearranged his jacket and looked at himself in the mirror, and then satisfied that he was presentable he sat down behind his desk to await developments. By this time he had practically forgotten about the strange creature he had been firing at in the village street.

So engrossed was van Gelder in his pleasant thoughts, he did not see Tank move past a window and work along the precarious ridge that ran around the side of the building. As a matter of fact, he never knew what happened when the ape leaped.

Tank hit van Gelder from the window in the far corner. The massive bulk of animal brawn, bone, and muscle shot through the room like a hairy thunderbolt. Tank's hands hit the Dutch official full across the throat and the man's head went back with a leaden crack before he could suck in his breath to let out a yell.

The electric waves of muscular action were switched off as though a

broadsword blade had cut off van Gelder's head. He simply went limp and rolled over into a corner. Tank got up from a cruel crouching position and stared at the man. He reached forward and yanked van Gelder's head up, and then by animal reasoning realized that he would shoot at him no more.

Then Tank stood up again and glowered about the room. He sniffed and let his beady eyes draw into blue-steel slits. He moved his massive head slowly, listened to the clatter of planes and the chatter of villagers outside, and then suddenly made a dart for the closet. He practically tore the door off with one jerk and with a wail of jungle despair saw his Boss trussed up inside.

He dragged him out and went to work on the bonds that held him. In a few seconds, by using his teeth and long, steel-spring fingers, he had his Boss completely released and his cold palms were methodically soothing Kirk's face and neck. In a minute Kirk pulled out of it and stared about from a sitting position. His eyes first saw the heap that had been van Gelder. He looked up at Tank and back again at the shapeless heap of humanity—and, somehow, it all clicked suddenly in his mind.

The throb of pain that made his head seem as large as a pumpkin could not erase the reasoning as to what had happened. He patted Tank's shoulder, scrambled slowly to his feet, and then made his way around the

desk. Tank began whimpering again and looked out of the window with an anxious grimace on his mug.

"What's up, Tank?" asked Kirk, glancing quickly at his wrist watch to try to tie up the time brackets. "What's going on?"

He tottered to the window and steadied himself against the ledge. The window fronted on the wide courtyard, and below he saw a group of Japanese Naval officers approaching the ceremonial steps of the building. They were being guided by two natives in gaudy sarongs and headsmen headdress.

Kirk stepped back and watched. He tried to figure it all out, but another Mitsubishi bomber hammering over the pile of huts brought into full focus the realization of what was taking place. That at least set his time bracket for him. He'd been out for nearly an hour!

"Get moving, Tank," he ordered. "Climb into this guy's clothes. We're going to play dirty Dutchmen."

CHAPTER III

A SIGNAL TO SINGAPORE

HE GRABBED van Gelder up and ripped off his white linen jacket. This he shoved at Tank and with a glance indicated that he was to put it on. He retrieved the pith helmet and rammed that on the ape's head and then pushed him around to the Dutch official's seat behind the desk. He buttoned the jacket, wrapped a light silk scarf about his throat with a stock knot, and placed him in an imposing position behind the desk.

"Now sit there and don't move until I tell you," ordered Kirk while he somehow mustered enough strength to drag van Gelder into the closet he had just left himself.

Then Kirk did a strange thing. First, he took a chair and placed it with its back to the wall not far from where Tank was sitting at the desk. He took van Gelder's machine pistol and put it on the chair. Then he sat down over the weapon and wound a length of heavy cord about his ankles in such a manner that his feet appeared to be securely tied. He placed his arms behind his back, and by a dexterous movement with his fingers managed to wind another piece about his wrists. The loose ends he tucked under him.

Then, with their stage thus set, this strange pair waited for the Japanese invasion.

There was a rattle of metal and clank of officialdom on the stairway below. The door was opened respectfully by one of the native headsmen who stood back to allow the first contingent of Jap officers to step inside. The first one in was Koji Yasui, stiff with black leather and pomposity. He leered grimly at Kirk and then bowed at the figure behind the desk.

"Very fine work," he said in precise English to Tank. "This is Herr van Gelder, I presume?"

"Who the devil did you think it

was?" came the unexpected answer. Tank's nose was twitching with anticipation and his face gave off the expression of one who spoke with little interest in the proceedings.

"Of course! Of course!" Yasui agreed, somewhat puzzled by the lack of respect he had expected. "You managed to intercept the container?"

"Went all over the wreck, but it apparently was damaged in the fire that broke out when he crashed. There's the tin."

That apparently came from Tank again and Yasui was so eager to grab the evidence he sought that he did not notice the lack of movement in Tank's mug.

He took the seared can, wrenched the lid off, and peered inside. He looked again and sniffed and his face somehow underwent a change.

"You see, it has melted," came from behind the desk.

"So it appears," said Yasui, with a gleam of hate at Kirk. "Well," he went on, "you rather overreached yourself this time, friend Kirk."

"We can't win all the time," said the American.

"This time you have lost and you are not likely to go around presenting bouquets to your enemies. We intend to take you to Tokyo and see that you experience Oriental justice."

"When?"

"After we have taken care of your friends at Singapore. Since they do not have your treacherous British-American plan, they will simply sit there in the harbor where we shall take care of them."

"When does that come off?" asked the figure behind the desk.

"At once, of course. We intend to waste no more time. It will be very simple tonight. Most of the vessels in Singapore harbor will be unmanned. They have conveniently arranged a special ceremony for the opening of the new dry-dock there and most of the crews will be ashore for the ceremonial ball and dinner the British are so fond of arranging for their American hirelings."

"But you can't get into the harbor. They have it blocked off with anti-submarine nets," came from behind the desk.

"Of course. But fortunately for us, neither the British nor the Americans seem to be able to tell a Filipino from a Japanese. It will be very simple to have the nets lowered at the proper time, since we have the right people in the right places."

KIRK'S MIND raced in spite of the throbbing from the blow he had received. He recalled that a very important flotilla of American warships had recently been sent to Singapore as a friendly gesture. If they were caught cold in Singapore harbor, it would mean almost certain loss of the British naval and air base there and, above all, Japan would have a predominance of power in the southern Pacific. This had to be stopped by some means.

"It has also been carefully ar-

ranged that anything that happens to the American ships there will somehow appear to have been due to rank carelessness on the part of the British, who already may feel that American naval strength is greater than the English deem necessary. This, I believe, comes under the head of Fifth Column activity," Yasui beamed at Kirk. "We, too, have our methods, Mister Kirk."

The officers behind Yasui beamed also, and Yasui spoke something to one of them who took out a note pad and stood waiting expectantly.

"I will dictate a message, Herr van Gelder," he said to Tank. "My Flag Officer here will code it and we will use your radio set to advise our South China Sea flotilla. Is that satisfactory to you?"

"Certainly. Make yourself at home," nodded Tank.

A Japanese officer took out a lead-covered signal code book and stood waiting. Yasui glanced about the room and then decided that the radio set was set in the wall behind the panel. He went over and slid one half of the door back and peered inside.

Kirk knew all he wished and he was anxious to get going now. He gave Tank a signal, let out a low cry, and kicked himself free from the loose bonds.

Tank picked up Yasui quickly and hurled him with tremendous force at the four amazed Japanese officers. The five of them went down like ninepins. Kirk had the lot covered at once and grabbed one by the jacket and ripped him to his feet. He made him bind the others carefully and then made sure of that one himself. They were all shoved into a corner and Kirk took possession of the lead-covered secret code book.

"The U.S. Navy boys can use this, until you can think up another," he grinned.

Yasui was hurt and slid to the floor when his knees buckled under him. Kirk let him fall and kept Tank away when the ape wanted to charge in again. He removed all their arms and swords with which they had encumbered themselves and then went over to the radio set. He studied it for a minute or so and then snapped the switches. He drew the wave length lever over to the Singapore RAF station. In five minutes, he had given them a suitable warning concerning the submarine nets and advised them to call off the dry-dock ceremonial until he could contact them later on.

"I think I nailed you in time, Yasui," he said to the unconscious Jap. "I fooled van Gelder with that English toffee tin, but I knew you would have spotted a few letters of the words 'Mackintosh's Toffee.' They gave me that when I left Borneo and I figured it might come in handy, in just such a case as this."

He threw the can down on the floor at Yasui's feet and laughed. Tank nearby was stuffing the guns in his big jacket pockets.

"WELL, what now, Tank?" Kirk asked his ape pal. "We may have saved the Navy guys at Singapore, but we still have to get that can there."

Yasui came to, stared about, and then glanced at the tin at his feet.

"You . . . you can't get away with this," he muttered. "You can't get away from here. You do not have the dictaphone record, so what is the use of taking needless risks?"

"We love taking risks, Yasui," taunted Kirk. "Wouldn't be any fun if it was always as easy as this."

"But you can't fool all the men we have guarding the bombers. You can't expect to get away with one of them."

"Your men would die for you, wouldn't they, Yasui?"

"That is our tradition."

"Swell! We'll give them a chance to and see if your tradition gag works. If it don't, you fry!"

Kirk went over their bonds again and then added gags to make it more certain. He tied them all up tightly and their sat them up against the wall and left them staring at him while he went back across the room and hammered most of the tubes and connections out of the radio set.

"And when your friends come to rescue you, Yasui, they'll find the real van Gelder in that closet. Herr van Gelder unfortunately broke his neck trying to wrestle with my talkative friend here. Still, you might like to stay on and give him a suitable burial; he's entitled to that much. You might also take time to plant a double-cross over his grave. He was a Nazi, of course."

And with that, Kirk nodded to Tank and the two slipped through a side door. They made their way down a piling and crawled along a heavy teak beam. Kirk sent Tank on ahead and then halted him while he carefully put a match to some of the dried-out palm fronds that reached down from the tall sloping roof. They waited until the thatch under the corrugated iron roof was well ablaze and then scurried away to a nearby hut and set that on fire.

Tank tangled with one or two natives who tried to interfere. They were simply grabbed by the wrists, tugged forward smartly, and then snapped like a gigantic stock whip handle and hurled screaming through the air. They set fire to three fairly large huts as they worked their way around the village and then came out at the far side and were able to creep unseen through the low jungle vegetation to the beach where the Japanese bombers were lined up.

The beach was in an uproar. The natives who had crept down to gaze on this new display of thunder birds were attracted by the blazes in the village. They scampered madly through the jumble of machines and went screaming up the dunes. Gradually, the Japs left in charge cut their forces somewhat and left in small groups to go to the rescue. Kirk gave a signal to Tank and pointed to a

TRAIN AT LINCOLN

U. S. GOVERNMENT APPROVED

FOR A REAL CAREER

IN
Aviation

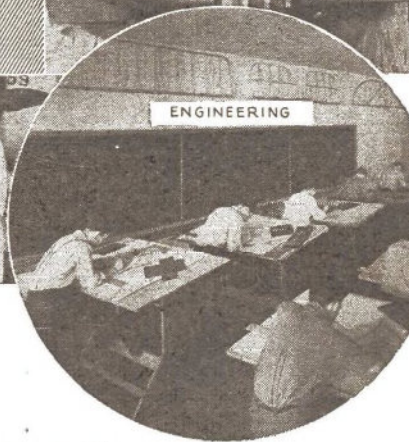

3 CAREER COURSES

AERONAUTICAL ENGINEERING

Here is career training in Aeronautical Engineering that prepares you for a REAL position as Engineer with an Airline or Manufacturer. While learning here to Design and Build airplanes, you have access to ALL our facilities . . . our Production and Maintenance Mechanics Schools . . . our Flying School and its large fleet of training planes. There is a distinct Advantage to you in taking your training at Lincoln, where the complete field of Aviation training is covered. Big demand for Engineers. High salaries paid.

AIRLINE MAINTENANCE MECHANICS

If you like mechanics, here's the course you should take. Graduates of our Government Approved Mechanics training are stepping into fine positions with Airlines, Airport Operators and Manufacturers. Good-Pay opportunities for hundreds more. Many earn from \$1800 to \$2400 a year. Training prepares for Government tests for A & E Mechanic Rating.

PROFESSIONAL FLIGHT TRAINING

In all our 21 years of training men for Aviation there has never been such fine opportunities for our Commercial Pilot Graduates as are open today. Airlines and Airport Operators are eager to employ our qualified Pilot Graduates. Many start at \$3000 . . . soon qualify for higher pay. Airline Pilots earn up to \$6000 and \$7000 a year. All Flight Training at Lincoln, fully Government Approved. Large fleet of modern Training Planes, Primary and Advanced. Plenty of cross-country flying experience. Ideal flying conditions.

MAIL COUPON TODAY FOR COMPLETE INFORMATION ABOUT LINCOLN TRAINING

LINCOLN AERONAUTICAL INSTITUTE (INC)

LINCOLN AIRPLANE & FLYING SCHOOL (INC.)

286 Aircraft Bldg., Lincoln, Nebraska

MAIL TODAY

LINCOLN AERONAUTICAL INSTITUTE
Lincoln Airplane & Flying School
286 Aircraft Bldg., Lincoln, Nebraska

I'd like to prepare myself for a real career in Aviation. Please rush complete information about Lincoln Training.

NAME

ADDRESS

CITY STATE



machine that stood in the clear, and the ape began to crawl carelessly down the slope.

Kirk ran along the beach top, stood high on a dune, and yelled that the village was afire and that their officers were trapped in the Controleur's hut.

Then he dropped down as if he were on his way back to the fire. The Japs, realizing for the first time the seriousness of the situation, then all scrambled off in the general direction of van Gelder's place.

Kirk turned when he was behind the dunes and raced back to where he had left Tank. He cut down the furze and low palms and was soon racing after the ape who was struggling with an unfortunate Japanese

sentry. Tank socked him over the head with the man's own pistol and threw the weapon into the jungle.

CHAPTER IV

THE JOURNEY COMPLETED

IN NO TIME they were aboard a free Mitsubishi bomber and trying to get the engines started. The planes had much the same general layout as a Douglas B-18 and Kirk soon had the Japanese engines ticking over. There was a flurry of shots from somewhere and a Jap Nambu gun spat at them.

Kirk suddenly remembered the Breda wreck which was still some distance away. He darted out of the

cockpit, down the bomb bay, and through the cabin door. Under a crazy fire from a Mitsubishi, he zig-zagged his way toward the wreck and scrambled at it just as an incendiary bullet found a gas tank. The tangle of wreckage gushed with a festoon of wild flame. A mushrooming vortex of smoke belched at him and drove him back, but he tried again from

the other side and finally crawled over and rammed his head and shoulders into the battered cockpit.

"Cripes!" he gasped. "I fixed old Yasui up with a smoke-box and get into a worse one myself!"

He had to struggle against the flame and smoke but finally reached what he was getting at. Well inside, he flipped up the breech flap of the

drift-flare tube and drew out a bright red can. It was that which contained the all important dictaphone record which carried the code formula of the war plans of the Pacific Fleet.

The can was cool in the drift-flare breech because that portion was built and insulated like a gun breech to protect the flare cartridges, and Kirk had thought of all that when he hid the all-important can away.

He tucked it in his shirt front, crawled through the smoke, and made as much use of the cover afforded by the wreckage as possible. Then he waited and started running again. The Japs began to fire from a nearby Mitsubishi, but before Kirk had taken twenty steps it suddenly subsided. He twisted and squirmed and made for the one they had selected and then saw what had caused the respite. A man, screaming and floundering, came hurtling out of an open gun turret. He went high in the air and came down starfish shape on the ground with a sodden thud. Another followed quickly.

Tank was at it again!

A covey of flying Japs tormented out of the Mitsubishi as the ape man cleared the cabin. They ran bellowing in all directions. Kirk got back to the ship he had selected and began to whistle in a strange low tone, but it was enough. In a second or so Tank caught the call and came cantering along the wing of one Mitsubishi and leaped wildly to another avoiding the desperate attempts someone was making to get him before he reached cover.

He came thundering into Kirk's ship with a grimace on his mug that came as near to being a smile as his boss had ever seen.

"Nice going kid," beamed Kirk. "Nice pitching in there."

And Tank beamed again and snuggled down near his boss after stroking a heavy paw over Kirk's head with all the affection of a fond father.

KIRK WASTED no time in getting the stolen machine away. He let her thunder down the beach while he took a short but intensive course in Mitsubishi flying while she thumped and hammered her way cross-wind until he could get her into the air.

The craft handled well even though she seemed heavy and Kirk brought her around carefully on the first turn before starting back westward for Singapore. He nosed her up while Tank sat and watched with none too much interest from the co-pilot's seat. The Mitsubishi climbed with a soggy gesture and then suddenly Kirk realized what was wrong—or right.

She was loaded with bombs!

He glanced over the instrument board and tried to figure out the instruction plates which were all printed in Japanese. He finally found the bomb release register and figured that there were at least six good sized missiles tucked away in the racks set below the floor. Then he swung over

Aero Book Reviews

Any volume described in this department may be obtained, at the price quoted, direct from the publisher named and at the address given. When writing for a book kindly mention that you saw it reviewed in FLYING ACES.

For the Serious

The Aviation Mechanic, by Carl Norcross and James D. Quinn, Jr., Whittlesey House, McGraw-Hill Book Co., 330 West 42 Street, New York City, \$3.50.

This book is *not* for the average fan, the one who is interested in aviation purely from the air and flying aspect. Instead, it is intended for the more serious students, the ones who want to do more than "just fly"—the ones who want to be mechanics.

Mechanics is the forgotten branch of aviation, and men in ground crews are usually referred to as grease-balls. However, the ones using that expression do not seem to realize that the real romance of aviation is on the ground and not in the air, for more aero improvements and advance have been made by non-flying workers than all the flyers put together.

We have more than a casual interest in this book, because of the subject it deals with and because we feel that the mechanic trade is too often being passed up by students for flying.

The Aviation Mechanic is a large book, having 563 pages, and is well worth the selling price. And while it is definitely technical in essence and background, the material contained is presented in a thoroughly understandable, clear fashion.

The only thing wrong we can find with books of this type is that there are not enough of them to be had.

An Illustrated History

Famous Planes and Famous Flights, by John Winslow, Platt & Munk, 200 Fifth Ave., New York City.

Twenty color drawings by Irvin L. Holcombe—depicting many famous ships from the original Wright biplane to the Boeing Stratoliner—are used for illustrations. These are in page-size plates and show vividly the great and rapid growth that has taken place

in this flying game.

Books of this sort are always good in an aviation library, for in a moment you can check up on important events without delving through indexes, contents pages, or other listings usually given in historical books in complicated fashion. Here, however, the process becomes merely a process of thumbing through the book until you find a photograph of the plane in question. Then, on the opposite page, all pertinent facts, including dates and names of pilots, are given.

Famous Planes and Famous Flights was published expressly with an eye toward younger readers, and for these the book is heartily recommended. However, we will even go further, and say that it is a great book for any aero fan to have on hand.

The Technical Side

General Aeronautics, by Hilton F. Lusk, The Ronald Press Co., 15 East 26th St., New York City, \$3.75.

First off, just a word about the author: He is now Director of the Technical Institute of Aeronautics, Sacramento Junior College, and was formerly Dean of the Boeing School of Aeronautics. Moreover, he is a certified Aircraft and Aircraft Engine Mechanic, a certified pilot with Instructor rating, an associate Fellow of the Institute of Aeronautical Sciences, and a member of the Automotive Engineers.

Here we have a modern technical book that seems to be thorough and complete in every respect. It runs 524 pages, which means that probably many months—if not years—were spent in compiling and writing the information contained.

Ronald Press, we should mention, deserves much credit also for the marvelous job they did in making this book so presentable. The paper is an excellent coated stock, the covering is heavy and embossed in a pleasing fashion, and the binding is of the best. All in all, *General Aeronautics* is definitely made to last many years.

Very little else can be said about a book of this sort, except that it's an engineering course in itself and belongs right up front on an aero bookshelf.

(Also see pages 64 and 78 for other reviews)

and swept back over the small island again and saw that the fires were blazing merrily. The natives and Japanese navy men could be seen scampering in all directions, but a few were making their way into the main building at the end of the long courtyard.

Kirk hammed down the fringe of the beach at about 170 and took a quick sight on the group of bombers. He held her steady and pressed two buttons on the bomb release panel.

The big Mitsubishi jerked after the scrawnch of bomb-bay doors and there was a gulping movement as a heavy explosive left the racks. Another jerked out and Tank sat up hard and stared about. Kirk shoved him back and whanged the big bomber over and peered out of the side windows to the beach below.

It seemed minutes before the projectiles fanged into the sand below and Kirk had a sudden fear that he had missed. But two gigantic gushes of flame and sand leaped up suddenly from amid the bombers and banged a double thud of concussion at the under sides of Kirk's stolen bomber.

The big ship almost went over on her back and she fell off into a dangerous side-slip. Kirk eased around, got her nose down, and finally managed to gather enough headway to make the controls take. She came out not many feet above the water and reached into a savage zoom for altitude.

Once she came out, Kirk looked across and saw that his bombs had scored with considerable damage. Two of the Jap machines were already fringed with flame. A wing panel of another had ripped up and flopped over hard across the roof of the cabin. There was smoke and chunks of dural in the air and another gusher of flame leaped up from somewhere in the middle of it all.

"That ought to keep them busy for a time," grinned Kirk. "Now maybe we can..."

But that was as far as he got. As he brought the bomber around again to head her into the west, a full squadron of Kawasaki fighters came boring down from somewhere above. They spat lead and streaked tracer lines of fire across the leaden blue afternoon sky.

"Come on, Tank!" yelled Kirk, slapping at the ape's shoulder. "Get going, boy! Find something that will shoot!"

Tank clambered out of his chair, peered up through the roof window, and disappeared down the companionway. Kirk rammed the throttles well up the quadrant and the Mitsubishi climbed smack into the formation of Jap fighters, just as he had done before. The unexpected move broke up the twelve-machine formation and one slapped a wing tip into another and then rammed together with their engines at about 230 m.p.h.

Kirk had not discovered where his fixed guns were operated from and he had to make the most of bash and

bluster. He squirmed in and out, actually making wild passes at the enemy fighters with his wing tips.

THEN, as Kirk cleared, there came the first cheering sounds from somewhere aft. Tank had obviously managed to get a weapon into action, because the Nambu gun is an exact copy of the American Browning .30 caliber weapon. At any rate, he had found one in a jerk-water mounting and had sense enough to go through the same loading operations and get the trigger dragged back.

Kirk knew the ape would simply point the gun and keep squeezing the trigger with little or no attempt to set a bead on the enemy, so he helped as much as he could by treading on the rudder pedals and making the tail swing. The effect was as good as might be expected. The swinging distributed the fire sufficiently to give a good spray effect, and one Kawasaki fighter was raked with a slashing of lead that cut his struts away; his top plane went off with a retch of outraged metal and the ship nosed down suddenly.

Kirk knew he was playing his luck too far, so he nosed down and took the only other chance open to him. He retracted the landing gear and then with unbelievable daring brought the Mitsubishi bomber down to the skipping-the-whitecaps.

The big bomber ballooning over the waves was difficult to handle, and more than once Kirk sensed that he was slamming the curved belly of the machine through the spray being flicked up by the rollers. Still it had to be done. The Kawasaki fighters were racing after them and desperately trying to get in a shot. But if the bomber was dancing against the criss-cross currents, the lighter fighters were having a wicked time keeping their noses in any particular direction. One fighter, getting down low to take a snap shot from behind Kirk's rudder, was nipped by a curler off a white-cap. His wing tip went down, tipped the top of a heavy roller, and she cartwheeled over with a tremendous scream and broke herself to bits.

The others zoomed up in fear and caution but Kirk sat there and gamely held his position.

By this time Tank had managed to get another cartridge container shackled to the gun breech and was again zipping off long bursts in the general direction of their pursuers. The effect on accuracy was none too good but it provided a visual sense of opposition that could not be laughed off.

The race was carried on for some minutes, but eventually the fighters had to give up. Kirk was playing too desperate a game and they did not have any too much speed or tankage to play very far with this madman. One by one they curled off, sought a safer altitude, and made their way back to a Japanese aircraft carrier skulking away somewhere near the small group of islands that dot the

REAL ENGINE VALUE



G.H.Q. GAS ENGINE KIT
NOW ONLY \$4.95

Identical Engine less \$3.95
Coil and Condenser

This is a miniature gasoline engine that really operates. Mass production methods and enthusiastic reception have enabled us to reduce the price from \$35.00 originally to the NEW LOW PRICE OF \$4.95. Over 15,000 sold in the last year—over 50,000 in use today. THE NEW IMPROVED 1941 MODEL KIT is ABSOLUTELY COMPLETE with coil, condenser, plug, simple illustrated instructions, gas tank, etc.

For Model Planes, Boats, Midget Cars.



All Parts Finished and Guaranteed.
All Machining Done.
No Mechanical Knowledge Required.
1/5 Horsepower; NAA Class C Engine

Average assembly time 30 minutes.
ONLY A SCREW DRIVER NEEDED

FACTORY ASSEMBLED \$6.50
READY-TO-RUN
Complete with Coil and Condenser

Dealers Wanted
Send for FREE literature or 6c for Jumbo catalog.

SEND ONLY \$1.00
Shipped Collect, C.O.D. Same Day.

G.H.Q. MOTORS, Dept. F, 40 East 21st, New York

AVIATION APPRENTICES

AIR-MINDED Young Men Interested in Training for Entering the Well-Paid Field of Aviation as Apprentices. Write immediately, enclosing stamp.

MECHANIX UNIVERSAL AVIATION SERVICE CO.
Wayne County Airport, Box 857, Dept. K6, Detroit, Mich.

COLT 45 CAL. Frontier Model

Casewood construction kit with working plans and all necessary hardware. Barrel and cylinder are machined. COLT 45 Cal. "FRONTIER" model kit, 5 1/2" barrel \$1.95
COLT 45 Cal. "FRONTIER" model kit, 7" barrel 1.70
COLT 45 Automatic Pistol kit 1.00
COLT 25 Cal. Automatic pistol kit .50
THOMPSON SUB MACHINE GUN model kit \$3.00
Savage Cal. 32 automatic pistol kit .75
LUGER 9 M/M auto. pistol kit w/4" barrel 1.75
LUGER 9 M/M auto. pistol kit w/5" barrel 1.90

All kits make beautiful full scale models.
Postpaid in U. S. A.
GUN MODEL CO.
Dept. FA-6, 2908 N. Nordica Ave., Chicago, Ill.

Dept. FA-6, 2908 N. Nordica Ave., Chicago, Ill.

FREE FIREWORKS CATALOG AND GIFT COUPON

WANT TO EARN FIREWORKS ASK US HOW

Have more fun for your money—buy FIREWORKS direct. With every order a 35c gift box of Salutes FREE.

SPENCER FIREWORKS CO.
BOX FA-150 POLK, OHIO

sea west of Singkawang in Dutch Borneo.

The battered but still racing bomber was brought up to a safer level and Kirk relaxed for the first time in hours. He steadied her for a long 300-mile flight and took time out to jack in the robot pilot and somehow managed to get the Japanese set working so that he could contact Singapore and explain what had happened since his last flight. He par-

ticularly wanted to tell them that he was flying a Japanese-marked Mitsubishi, because he knew full well that he would never get away with any down-low flying if a flight of British or American fighters decided that he belonged to the ungodly.

The message did the trick, however, for before they were within fifty miles of the Strait of Singapore a flight of American Grumman fighters dropped out of nowhere and huddled

around the Jap ship and made certain that Coffin Kirk and his red tin can got safely to the British Malaya naval base.

And by the time they had landed, Tank was curled up in the co-pilot's seat with Herr van Gelder's pith helmet tilted so that it would shield his eyes.

"Nice guy to have along," said Kirk when he thought it all over.

THE END

ON THE LIGHT PLANE TARMAC

(Continued from page 25)

cellent and did his best to teach me all I should know. He particularly stressed that one should always watch the wind.

The airport nestling among the mountains of East Tennessee was large enough to accommodate anything but a B-19. And due to the mountains, there was little traffic to contend with and the port was not controlled.

It was a balmy August day with little wind, but said breeze was shifting from right to left. The idea occurred to me to try some landings.

No sooner thought of than I began. I climbed into the Taylorcraft and taxied to the bulb. There I waited until a Cub came in over me and then I took-off.

She came off nicely. I circled the field and came in. Gosh! A beauty! I could hardly feel her touch and I mentally bet myself two bits I could do it again.

There was a slight rise at the intersection of the runways so that from one bulb it was impossible to see the opposite end of the runway. I stopped, glanced quickly about.

There was not a ship in sight, so I gave her the gun.

She picked up speed in a hurry and seemed to be running farther than usual. No matter; she came off okay.

Then . . . What the? . . . Who? . . . Where did that guy crop up from? He sure was coming! Head on and not fifty yards away was a Cub that had taken off from the opposite direction and we had both reached the rise at the intersection, facing each other. Fortunately, an instructor was in the Cub and he threw it over in a steep right-hand bank. I did the same. We passed with inches to spare and our wing tips practically dragging the ground.

I straightened out and glanced up at the wind tee. It was pointing in the same direction I had taken-off! The wind had shifted 180 degrees!

My carelessness had almost caused a serious accident—and I thought I knew all about flying!

Moral:—Watch your wind and keep your mind on what you are doing. You don't get so smart that you can't kill someone.

WAYNE L. WHITE
Decatur, Ga.
THE END

Test Yourself

- Who is Marie McMillin?
- How are Army ships kept in Condition?
- What is the AT-12?

IN EVERY issue of FLYING ACES you'll find articles, stories, photographs, departments, and model features which answer many aero questions. Next month's number is typical—it defines the above questions and many others. And, as a special treat for you fact fans, we'll have five extra articles!

Don't miss the July issue of F.A.! If you are not a subscriber, take advantage of the Special Offer below. If you already subscribe to FLYING ACES, perhaps you would like to get a subscription for a friend.

Special Introductory Offer

9 Months of FLYING ACES for \$1.00

Add 20c for Canadian subscriptions; 60c for other foreign countries.

----- Fill Out and Mail Now -----

Subscription Dept., FLYING ACES
67 West 44th St., New York, N. Y.

Enclosed is \$1.00 for the next 9 issues of FLYING ACES. Start with the
..... number.

Name

Street and No.

City State

CARRIERS

(Continued from page 22)

was for rigid airship construction!

At Lakehurst, N. J., the Navy Balloon School is entering its twentieth year of operation. The students receive their training in free balloons, graduating to blimps. One glance at a blimp housed along with the decommissioned *Los Angeles* in the massive dock—a dock that was built for majestic *Akrons* and *Macons*—is enough to remind us what has been, and could be again.

In his report to the Secretary, Admiral Towers commends the blimp airship personnel of Lakehurst for noteworthy results in their cooperation with the fleet as submarine scouts. The airship's hovering ability, and resultant exceptional visibility, has proven lighter-than-air craft as an excellent counteractive element in all-out submarine warfare. And if England at this time had a fleet of airships, she could very easily escort her convoys through the danger lanes and save thousands of tons of shipping from Nazi U-Boats and surface raiders!

Admiral Towers concludes his report to the Secretary with seven recommendations, the seventh of which is that we "pursue a moderate airship building program and continue training personnel in non-rigid airships."

America may soon be desperately in need of a fleet of dirigible aircraft carriers to scout her extended coast

lines. Perhaps, with the accent on national defense at this time, we may soon see our airship personnel with something *real* to fly—something to prevent their scattering and loss to American aviation, and something with which to prove the actual value of airships as scouting aircraft carriers.

THE END

PRISON SCAMP
(Continued from page 36)

fight, soldier. Some second loopy got conked with a bottle over in the estaminet. He dumped cognac down a Captain's neck. They took the loopy to the nearest croaker. Awright, beat it!"

"Pooh Johnson!" Phineas gulped. "What outfit was he with huh? Well, I will maybe find out by accident. Maybe there is a letter in his pocket an'—"

Phineas found the letter from the U. S. It was from Johnson's ma and it told him to keep on wearing his red flannels before he got cold in Detroit. That line stumped Phineas. The letter was addressed to Pvt. Joe Johnson, Co. C, 27th Div., A. E. F.

Twenty-four hours later, Phineas Pinkham, wearing a phony blood-stained bandage over the lower part of his face, was slumped against the sandbags of a trench surrounded by hundreds of other buck privates. He was in no-man's-land, an ordinary dough. The Krauts were only two hundred yards away and they were heaving potato mashers as fast as their arms would work. Krupp guns behind the Jerry ditches kept pasting the Yank trenches with scrap iron.

"What a guerre!" Phineas gulped. "I wonder how Lieutenant Cuthbert Heathcliff is? Johnson will git killed maybe an' Papa Johnson will put a ten thousand dollar addition on the delicatessen with the insurance money. But the real Johnson will be alive somewhere all the time."

Six hours later, the Boche put on a weird drive, slammed against the Yank trenches, and they could not be stopped until they had driven almost to Labelle. The Krauts took eleven hundred prisoners, and among them was Private Joe Johnson. Three hours after the push, the Jerries began sorting out the catch and they shipped them back to various klinks in Alsace.

Phineas wandered up and down the barbed wire enclosure, feeling more miserable than a hairless Mexican pup caught in an Alaskan blizzard without as much as a muffler on. He had been treated with terrible indignity, having no officer's bars to soften up the tough Jerry wardens.

NOW, LET US go to the drome of the Ninth Pursuit Squadron in Bar-le-Duc where pilots were discussing one of the most puzzling cases of the entire war.

"The guy who took that new Spad up gave his name as Cuthbert Heathcliff," Bump Gillis said. "That Italian airplane wizard described him perfect as Pinkham. But he must have had astigmatism, because they got Phineas in Labelle an' have him locked up. He's got amnesia from havin' been walloped over the dome by a vin rouge bottle. The guys who have seen him claim he looked like a Yank, so how could he be Cuthbert Heathcliff?"

"Yeah," Major Rufus Garrity roared, his brain trying to tell him something. "That Bugatti guy is tryin' to recover damages from the Frog government an' says relations with Italy will be strained if they don't cough up. This Pierre Laval, who put his dough in the new crate, says his relations with his own country will get strained, too, if Poincare's cashier don't dig into the till. That Bugatti-Spad is worth twenty-five grand an' the costs of the damages to Laval is ten times that, he says, because nobody will take a chance on the thing again. Cuthbert Heathcliff—Where in Hades is Pinkham?"

"He went to Paree," Captain Howell offered. "You can't prove it," Garrity howled. "Cuthbert Heathcliff. That is the sweetest name I ever heard a man child called. Somethin' is screwy! Who else would dare to take that Bugatti up and fire its cannon? Any pilot in that sector would have known that the Rumpler had Limeys in it. Whoever it was, he will get a hundred years in a military can."

Bump Gillis' think-tank was throbbing and he went to his hut to get aspirin. He rummaged into a lot of stuff piled on a trunk to get at it. He found a dog-eared novel there that Phineas must have picked up somewhere. Yes, he remembered coming in one night to see Phineas absorbed in the story. Bump picked it up. The name on the cover was: MORE TO BE PITIED THAN SCORNED, by Emily Brondy.

Bump flipped the pages. He read a paragraph.

"You are a cad and a mountebank, Cuthbert Heathcliff! How dare you flaunt your paramours right in front of my sister's face. You scoundrel, you! I shall give you the punishment you so rightly deserve. On guard, Cuthbert! You will rue the day you—!"

Bump's undercarriage slipped from under him. He sopped his face with a handkerchief three feet square and soaked it the first swipe.

"It was Phineas," Bump choked

NEW AERONAUTICAL BOOKS

COMMERCIAL and PRIVATE PILOTS: New "Aeronautical Training" fully covers new multiple choice examinations, with drift, off-course and alternate airport problems plotted and solution given. Lead factor problems also solved. Commercial examinations are shown in separate section of the book. Navigation, Meteorology, Aircraft, Engines and CAR covered. Just published—11th edition only \$2.00 postpaid, or C. O. D.

INSTRUMENT FLYING by Lt. Comdr. P.V.H. Weems, U.S.N. ret., and Charles A. Zwenck, Instructor, U. S. AIR CORPS. A new and different book known as the "Howard Stark edition" written especially to prepare the pilot for the government examination for "Instrument rating." Radio-Telephone Permit included, with Meteorology, Radio-Orientation, let-down, offcourse and alternate airport problems. Deluxe edition, red leatherette cover with gold letters. Only \$4.00 postpaid.

FLIGHT INSTRUCTOR: A new quiz text covering the scope of the written examination for flight instructor rating. Illustrated with pertinent diagrams. \$2.00 postpaid or C.O.D.

GROUND INSTRUCTOR. A new book, prepares for government examinations on Navigation, Meteorology, Aircraft, Engines and CAR. Why fail? Only \$3.00 postpaid.

A & E MECHANICS RATING: Airplane and Engine Mechanics—Can you pass your written test? Send for new quiz book covering Airplanes, Engines, and Mechanics' Civil Air Regulations. 156 pages, fully illustrated, with complete sets of latest examination questions. Only \$3.00 postpaid or C.O.D.

NAVIGATION PLOTTER, (Dept. of Commerce type) is necessary for all problems involving drift, letdown and offcourse, including alternate airport problems. May be used when tablets are not available. Complete with large leatherette Navigation Note Book and instructions, only \$4.00 postpaid.

AIR NAVIGATION (Gold Medal Edition) includes meteorology. \$5.00 postpaid.

SIMPLIFIED CELESTIAL NAVIGATION by P.V.H. Weems and E. A. Link, Jr. \$3.00 postpaid.

DALTON MARK VII AIRCRAFT COMPUTER. With book of instruction . . . \$7.50.

Order From

Pan American Navigation Service

1435 Flower St., Dept. FA, Glendale, California

LEARN TO SHOOT STRAIGHT WITH BENJAMIN



For Target—Small Game—Camping—Guaranteed—Accurate—Practical—Economic—Safe—Clean—Quiet. Adjustable Force—Amazing Maximum Velocity. No Smoke or Fumes. Bolt Action—Hammer Fire—Hair Trigger—Safety Lock—Hand Pump. Single Shot BB with 1 lb. shot \$5.50; Single Shot Cal. 177 or 22 rifled with 500 pellets \$10.00; BB 8-Shot with 1 lb. shot \$10.00; Holsler \$2.00. Also a complete line of Benjamin Genuine Compressed Air Rifles for BB and cal. 177 or 22. No license required from dealer or factory. Write today for complete specifications and free targets. BENJAMIN AIR RIFLE CO., 850 Marion St., St. Louis, Mo., U. S. A.

8 MILE RANGE-WIDE VISION
BINOCULARS
15 Days Free Trial \$4.75
Postpaid or C.O.D.

Comes complete with case and straps. Well-ground powerful lens. Easily focused for all distances and eye widths. Latest features. Ideal all-weather binoculars. Guaranteed. If not satisfied after 15 days trial, money refunded. **VOGUE CO., 8450 S. Ashland Dept. 121, Chicago**

LEADER'S SUPER DETAILED SOLID SCALE MODEL

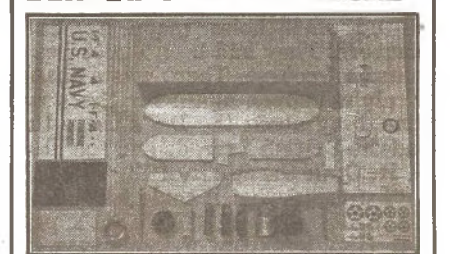

Actual photo of BOEING F4B4 Kit
BOEING F4B4
Kit contains all balsa parts cut to outlined shape, aluminum drag ring, eye bottles of liquids, wheels, celluloid motor, metal propeller, sandpaper, more than enough balsa for struts, wire, pins, insulators, and clear full size plans.
COMPLETE KIT 50c

add 10c for postage
TAYLORCRAFT 50c

COMPLETE KIT 50c

add 10c for postage
Both kits for only \$1.00 postpaid
WE CARRY A COMPLETE LINE OF RUBBER AND GAS MODEL AIRPLANE, BOATS, and RACECARS KITS and SUPPLIES. SEND 5c FOR PRICE LIST
Dealers: Send for Discount! Use Letterhead
LEADER MODEL AIRPLANE CO.

5130 So. Damen Ave. Dept. F-6 Chicago, Ill.

out. "But why ain't he in his clothes? I'll keep his secret, for even a dog should not get what he would if the police find him. I would indeed be a scoundrel and a mountebank if I did not burn this dastardly evidence of his folly. Er—I—" Bump hurled the book across the room and began to wish he had his hands on Phineas' throat. The Limeys might have succeeded in their crazy mission and then nobody else would be asked to steal a D-7.

Meanwhile, Lieutenant Phineas Pinkham, sans credentials and alias Johnson was one of the occupants of the prison camp at Rochefort. He dropped seven pounds of meat off his bones in three days, for bread made out of potato jackets and old shavings dunked into acorn soup will never put a humming bird in condition to fight a bluejay. The Kraut in charge of the calaboose was no King Cole. Phineas found that out the day he was brought before Himmler for an infraction of the rules.

"So!" Himmler snapped. "Der American bummer named Johnson, Ja? He draws der picture of der Crown Prince on der vall undt giffs him der big nose, hein?"

"Somebody shoved me an' the pencil slipped," Phineas said. "Why, I was born in Bavaria an' would not insult none of the Kaiser's family."

"Idt ist two days in solitary mitout food," Himmler yelled.

"Dankyshane," Phineas sniffed. "It is what I been wantin'. If I look at that slop just one more day—haw-w-w-w-w-w-w-w!"

"So? Vell, idt giffs three times der zoop undt blackbread undt you will eat efery bite. Hah-h--h-h! Undt try undt eggscape, please! Nefer haff I lost der man. Efen by chief of police Strudelburg, Heinrich Himmler—!"

"That is the way to cross them Krauts," Phineas said later as he sat in the dark cell gulping three times his share of acorn soup. "I must not let my resistance git low as there is a chance. Only a Pinkham would see it—or a Johnson. Haw-w-ww!"

Seven miles from the prison camp there was a squadron of Jerry planes. A prisoner had told Phineas that Himmler had sent a batch of prisoners over there one morning to fill up shell holes made by Yank bombers. They had been under heavy guard, of course. There was a chance it might happen again for there was something about the D-7's there that had the British Brigade and the Yank G. H. Q. in the spirit of St. Vitus.

"I wonder what it could be?" Phineas had pondered. "Well, let's page Mr. Handley. Haw-w-w-w-w-w-w!"

Phineas had a lot of time in which to think in solitary. By this time, he knew that Lieutenant Cuthbert Heathcliff had been exposed as a fraud and he would rather it be Johnson who would try and explain it to the Judge Advocate in an A.E.F. court of law. Johnson would no doubt get introduced to a wheelbarrow and a Frog sewer project at Blois. But maybe they would accuse the private

of murdering the officer who had posed as Heathcliff!

Phineas had to admit that the whole thing he had started was even too fantastic for a Pinkham to have arranged.

Yank brass hats got another shock on their side of the lines. The list of prisoners captured in the Labelle setback was made public to the official A. E. F. journal, *The Stars and Stripes*. It listed under the J's: "Pvt. Joseph Johnson," Bronx, N. Y.

"Then who has amnesia?" Garrity yelled. "I bet those fatheads didn't clean off that guy's face. I'm goin' to Labelle and look at that mug! I guess you guys remember the time he faked a spell of that amnesia on me! Oh, I got that bum where I want him!"

Garrity went to Labelle, to help clear up the mystery. He returned to the Ninth Squadron two days later in a nasty mood.

"It wasn't Pinkham," the C. O. growled. "An' he wasn't kiddin' about havin' lost his memory either. Oh, I wish I was psychic. Johnson is in a hospital on this side of the lines and he was also captured an' took prisoner. Nobody has heard from Pinkham. Shutup, don't none of you dare ask me no questions or I will slug you!"

PHINEAS CAME OUT of a solitary with spirits up to snuff and more weight on his bones than when he was tossed in. Heinrich Himmler asked as to the condition of the fresh Yank.

"Ach, Excellenz," a Kraut said. "Das bummer is nodt human. He vas vistling a song aboutd keeping der fires burning in der homes. Loogk, he efen giffs idt der lighdter for der present. In his shoe he had idt."

"Das ist a gut lighdter. I will keep idt, Gloppermann." Himmler pressed a button and a stream of vile smelling water caught him in the eye. The Boche warden gripped the edge of his desk with both hands and finally controlled himself. "Idt ist a nize prison camp undtill das Johnson ist come here. Giff him de chance to eggscape, Ja? How I hate das Johnson! I could kill him to death! Raus mitt you, Gloppermann!"

That night, the Yank prisoners were lifted right off their hard couches. A bomb dropped a hundred yards from the stockade. Anti-aircraft shells began to heat up the skies and over all there was the droning of power plants.

"A raid, fellers," Phineas yipped. "Listen to them eggs crack up over there. Boys, I just saw the top of a hangar skim across the yard. Go to it, you Limeys. Haw-w-w-w-w-w-w! I bet Himmler is under a table right now! That sourpuss was baptized in a pickel barrel."

Boche guards were doubled and they made threatening gestures at the prisoners with their Heinie Springfield.

"That is what I call a shellackin', huh?" Private Johnson yelled. "Worst than I ever saw done to a

floor. The Kaiser will have to dig down for more dough. Haw-w-w-w-w!"

"Yell off der head," Himmler himself thrust in at the prisoners. "Idt giffs no sleep in der morgen, bummers! All der holes must be filled undt I ledt you fill two all by yourself, Herr Johnson! Ha! Maybe idt is laughing you feel like now, hein?"

"Oh, no! Not that!" Phineas suddenly gulped. "I have got a weak back ever since I fell out of a pushcart, your Excellenz. You would not be so cruel, would you?"

Herr Himmler feasted his peepers on the face of his pet peeve. "Ah Gott! You vill shovel der gravel all der tag undt part of der next. This time I vill break you!"

"You are a hard man, Himmler!" Bombs continued dropping and Boche scrapiron kept reaching for the Handley-Pages. When the bombers had unloaded they swung about and droned over the stockade.

"Oh, you are pals, huh?" Phineas yelled, shaking his fists aloft. "It is only slaves you make out of your own flesh an' blood. Bummers!"

"Remember, Johnson," Herr Himmler said with his eyes aglow, "three o'clock in der morgen. Ho ho!"

Phineas did not sleep a wink. At the zero hour, Boche came and selected a bunch of Allied prisoners for labor detail. Johnson, of course, was among them. The thin column of prisoners wriggled out of the stockade and trudged toward the pocked Fokker drome. Arriving at the scene of the smearing, Phineas chuckled inwardly. What a mess. Two Fokkers were in scrap. Two hangars were gone. There were about eleven holes in the tarmac.

The Staffel leader was bandaged like a mummy and he sat on an ammo case and kept swearing at the R. F. C. Boche pilots wandered around in a daze. Seven Fokker jobs were out on the tarmac and mechs were digging into their viscera, looking for possible complaints.

"Now, Phineas," the Boonetown miracle man told himself as a shovel was thrown at him. "It is a job tougher than you have had to do yet, but, remember, it is for the Allies and a flyer named Pinkham. Haw-w-w-w! Just work over close to that Fokker there that seems to be warmin' up. Whoever heard of a dough bein' able to fly, huh? Only out of the doorway of a estaminet."

"Raus mitt!" roared a tough Boche who had been assigned to Johnson. He had his orders from Heinrich Himmler. "Gedt to vork undt stop der loafing or idt giffs sticks in her pants witt der bayonet."

"Go soak your dome, mushface," Phineas growled and bore down on the shovel. Sweat began to pour off the Pinkham pan. Slowly, he edged toward the Fokker, the grawny Kraut foreman following him. Big Jerry trucks came with fresh supplies of fill. One stopped close to the Fokker. Phineas let his eyes rove. The Heinie pilots were in a group over by Staffel headquarters. All the

Boche guards but the one assigned to Johnson seemed lackadaisical.

"Ach, my back!" Phineas groaned and leaned on his shovel. Himmler's pet prison attache stepped in close and lifted his gun to poke it into the meat of the Pinkham empennage. Without pausing to reconsider, Phineas whirled and thrust out his foot. The Boche tripped over the heavy U. S. Army issue brogan and slid down into the shell hole, his chin leading the way.

Private Johnson dashed for the Fokker, leaped to the pit, and cracked down on a German ackemmas's pate with his fist. One thrust was all that was needed to clear the D-7 of the stunned Kraut, and then Phineas was in the office for better or for worse and he jammed in throttle and hopped the chocks. The fighter nearly capsize, but a desperate prayer from the Pinkham lips straightened it out.

A siren began shrieking as the Fokker picked its way through the shell holes as daintily as an old lady avoiding mud puddles while crossing a street. A truck driver threw a shovel at the Fokker and washed out the only man who had a chance of stopping Phineas. Allied prisoners yelled encouragement to their champion and machine guns started popping. A Boche pilot jumped into a crate, gunned it away, and skidded too close to a halfclosed up shell crater. The Jerry drome was in an awful dither.

Phineas cleared the danger area and thundered toward the great open spaces. Bordering the field were Kraut batteries, and shell tossers rushed to their posts. The Fokker D-7 lifted its wings and Phineas backsticked and then fed the Mercedes plenty of juice. The thing nearly flew out from under his pants and climbed like a crow that has just been missed by the first load of a shotgun.

"Wow!" Phineas yelled. "What do they put in these things? I will climb out of that shell-fire in less than twenty seconds—I hope. It's lucky for me that this was the drome where them souped-up Fokkers was kept. If I could only see how Himmler will look when they tell him! Haw-w-w-w! Oh-h-h, Maddymoselle from Armentieres—parley vo-o-ose. The Krauts are smart but they don't know the J—uh-uh, there is more Fokkers comin'. I have got to git this crate down whole. I wonder how high I can go?"

NOT far from Epernay, on the drome of a British Bristol squadron, a sentry rubbed his eyes and looked up into the sky that had another hour to wait for dawn to brighten it up.

A plane was nosing down, coming through a chunk of ceiling, but it was making no sound. Fifteen hundred feet from the carpet its engine began to perk up. Br-r-r-r! Br-r-r-r-r! The sentry spotted the Maltese cross on its wings and took a couple of shots at it. Then he ran across the field, yelling his head off.

Pilots poured from huts and

\$7.95 COMPLETE GAS OUTFITS \$7.95

P.P. P.P.

BIGGER AND BETTER—NOTHING ELSE TO BUY

The lowest complete gas combination in model history. Both are complete including motor, model, timer-wheels, prop, etc. NOTHING ELSE TO BUY—JUST BUILD AND FLY. \$7.95 complete.

- 1—SYNCO MOTOR KIT COMPLETE WITH COIL AND CONDENSER
- 2—MERCURY "BULLET" GAS MODEL
- 3—GAS PROP
- 4—HYDRAULIC FLIGHT TIMER
- 5—BOOKLET ON MOTOR REPAIRS
- 6—RUBBER GAS WHEELS
- 7—TWO BATTERIES

48" Wingspan. 14 oz. Weight (with wheels and prop)
Climbs like a sky-rocket. A thermal catcher if there ever was one. Designed for small bore engines. Kit is complete with alum. Cowled nose, Wire, Cement, Dope, Celluloid, Tissue, Balsa strips, cut to size, full size plans and printed sheets, etc. Price of kit, if bought separate, \$15.00 P.P.



\$4.95 for motor alone.
\$5.95 for motor with coil and condenser.

DE LUXE COMBINATION—10 BIG ITEMS

- 1—SYNCO B30 GAS MOTOR ASSEMBLED READY TO RUN (\$7.95 alone)
- 2—MERCURY "BULLET" GAS MODEL
- 3—MERCURY GAS WHEELS
- 4—VARNISHED GAS PROP
- 5—HYDRAULIC FLIGHT TIMER
- 6—ELECTRIC SOLDERING IRON AC or DC
- 7—3 GASMOTOR WRENCHES (in leather case)
- 8—MAGNETIC INSULATED SCREWDRIVER

Send 3c stamp for latest catalog of motor, kits or supplies. Dealers write

MERCURY MODEL AIRPLANE CO.

9—BOTTLE OF 70 S.E.A. OIL

10—BOOKLET ON MOTOR REPAIRS

\$10.00

P.P.

TRADE IN your old motor! We will allow you \$1.50 no matter what condition or make. Include all parts. Send \$8.50 and that old motor for this complete gas outfit!

watched the Fokker sweep in. The C. O. came out in his union suit and ordered the mechs to light some petrol on the terra firma. The ensuing blaze nearly burned the Fokker up because Phineas sat the Boche crate right in it. He came out of the fire, worried the Boche plane to a stop, and half-climbed, half-fell out of the pit.

"Lieutenant Cuthbert Heathcliff reportin'—er-I mean Pinkham did it ag'in—I mean Johnson escaped," an addled Phineas forced out as R. F. C. pilots grabbed at his tattered olive drab. "Was up to twenty-four thousand"—look at the altimeter, as I bet it is as stiff as me. Nice of you bums to light a fire for me as I was froze clear to the tonsils. There is the bus you was after. Call up Garrity quick. Ninth Pursuit Squadron, Barley Duck. Oh-h-h-hh!"

"The blighter fainted," a non-com said. "Johnson? Pinkham? Strike me bloomin' pink and purple if there ayn't a dog-tag 'angin' from around his neck. It says he is Leftenant Phineas Pinkham, right 'nough. Gor blimie, but Johnson ayn't been no place, so how is it he come back?"

The C. O. of the Bristol Squadron sat down to think it over. "Might have known. I met Pinkham once in Paris. He stole a taxicab, sold it, and then bought it back three hours later for the chap who owned it. Went to jail and walked out of it an hour later wearin' a jolly old gendarme's uniform. I say Allerby, get me those aspirins in there like a good chap. Bottle of brandy, too. Both bottles, old thing."

"So that's the blarsted beggar who shot at us with a Bugatti-Spad cannon, what?" a British pilot still leaning on a crutch said with awe. "No end of a fuss he's started. International complications. Another backer of Bugatti's, Virginio Gayda, newspaper owner in Italy, also wants a settlement. Had half built a factory to manufacture the Bugattis. Expected the Allies to order at least a thousand. Terrible mess all around, what?"

NEW! 1941 MODEL POCKET NO Tubes Batter. Plug in RADIO!

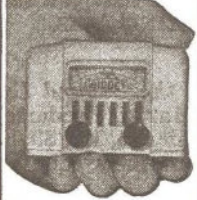

DURABLE PLASTIC CABINETS

DUAL BANDS—MAGICTENNA—MICRODIAL

Fits your pocket or purse—Wt. 6 oz. Small as cigarette package. Receives standard & some short wave. PATENTED POWER RECTIFIER. No tubes, batteries. H.I.—radio cozy tuning slide "MICRODIAL". M. L. OF ILL. SAYS: "MIDGET RADIO WORKS FINE!"

ONE YEAR SERVICE GUARANTEE

Sent complete ready to listen with instructions and tiny phone for use in homes, offices, hotels, in bed, etc. SIMPLE TO OPERATE—NO ELECTRICITY NEEDED!

SEND NO MONEY! Pay postman only \$2.99 plus postage charges on arrival or send \$2.99 (Check M.O., Cash) and yours will be sent postpaid. A MOST UNUSUAL VALUE! ORDER NOW! FREE! PLUG IN "MAGICTENNA" ELIMINATES OUTSIDE WIRES!

MIDGET RADIO CO. Dept. AC-6 Kearney, Nebr.

"G" LINE FLYING

Sensational - New - Thrilling



GAS POWERED SUPER SPEED PLANES FLOW UNDER FULL CONTROL. NOT RADIO CONTROLLED. Produced by Patent Model.

THE BABY SHARK

Newest "G" Line Sensation

Designed for all Class A & B Motors, the B A B Y SHARK flies at tremendous speeds of from 50 to 75 M.P.H. Amazingly Stable in Flight.

COMPLETE KIT, Only \$1.98. Postage 25c

Illustrated Descriptive Folders 5c

VICTOR STANZEL & CO. Schuylburg, Dept. F, Texas

Announcing To

MODEL RAILROADERS-DEALERS

JOBBER-MANUFACTURERS

A complete line of Model Railroad Cast Metal Parts from one source. The most complete range of finely detailed scale railroad parts in the country. Almost anything you want in any of the three popular gauges—0, HO—OO. Dealers—Jobbers—Manufacturers! Write for detailed information and price list now. Send 5c for illustrated catalog on R. R. equipment.

SELLEY MFG. COMPANY

1375 GATES AVE. Dept. 106 BROOKLYN, N. Y.

AVIATION JEWELRY

25c EACH



ALL ILLUSTRATIONS ARE ONE HALF ACTUAL SIZE

1037. Miniature copy of the Martin Clipper. .14K Gold Finish. 2 1/2 inches long.
1041. Brightly colored enameled American Flag. .14K Gold copy of the Douglas Trans. attached.
1038. Wings and Prop pin. .14K Gold finish 1 1/2".
1042. Military Pin. .14K Gold Finish. Handsome Letters and China Clipper.
1005. Wings, Prop and Motor pin. Gold plated.

Send 25c For Any Pin Or 65c For 3 Pins

A catalogue containing jewelry, sketches, photos, etc., will be sent free. Or send 3c for catalogue only.

CRAFT ART COMPANY DEPT. L

246 FIFTH AVENUE NEW YORK, N. Y.

"Here's another dogtag I found in his pocket," the British R.O. gulped. "Joseph Johnson, Bronx, N. Y."

"I say," the Bristol boss begged. "Dash it all, isn't the thing jolly well enough of a scramble as it is? Is the Leftenant conscious yet?"

"Rawther. Cawn't understand the bloomin' chap, though."

"Well, I *am* Lieutenant Phineas Pinkham," the Boonetown wonder yelped. "Who wants to make some-thing' out of it, huh? I was took prisoner by the Krauts in the last battle and tossed into a klink over there. I stole one of them new D-7's for the

Allies. If that does not even things on the law books, then I will go back and steal the Kaiser if you will git me a fresh change of linen. Awright, call up the U. S. cops an' see if I give a—!"

There was not a brass hat in France who would agree to make an example of Phineas when the news leaked out. Phineas rode back to Bar-Le-Duc with a member of the Frog Chamber of Deputies and two generals, one named Gamelin. Major Rufus Garrity had to keep his lip buttoned and all the things he had saved up to say to Phineas went bad

inside his spleen. The Boonetown jokesmith had the world by the em-pennage again with a downhill pull.

Heinrich Himmler, however, had fared badly. Haughty Junkers lifted him out of his post at Rochefort, busted him to second class sergeant in the Heinie army, and put him in charge of a burying detail.

Himmler, as he trudged around the Jerry backyard supervising the disposal of the liquidated Boche doughs, swore by all that was holy and unholy that he would someday get hunk with all 'German citizens who didn't have Teutonic capelaries squirting through their pumps.

"Undt idt vill be when there are no Junkers around to stop me, ja!" Himmler howled. "Some tag der common people vill haff joost as many rights as der verdammt Junkers. Ach Himmel! So gut was efert'ing by me before I meet das Johnson! But I vill wait undt wait!"

PIERRE LAVAL, Virginio Gayda, and Signor Bugatti threatened the Quai D'Orsay with no results.

"Wait until the next war," Bugatti roared at Poincare's cabinet members. "Just wait, shoos!"

"Hah," Gayda leered. "I hope I will have something to say who we will fight with the next time, my fran's."

"Fight?" a Frenchman said. "So many times you are chased across the Piave this time, Gayda, always the Allies keep sending help to chase the Germans back encore. Bah!"

"That is enough! I will not forget the insulto!" Gayda yelped and tugged at Bugatti's sleeve and took a powder. "Already I know a man who we should seek out, Signor!"

PHINEAS PINKHAM looked up from his desk when Donald Gillis walked in.

"Hello Carbuncle!" the salesman said. "You look worse than you did in 'eighteen, if possible."

The president of the Boonetown Novelty Company gulped. "Sometimes I wish the Boche had knocked me off, Bump. Look at these pictures of Himmler and his Gestapo persecutin' them people who never did nothin' to nobody. It is all my fault, Bump."

"You have been hit by a flu germ for Phineas," Gillis said and reached for a cigar. "Now about this order for—"

"Sometimes I wish mirrors was not invented," Phineas went on. "I look at myself in one and tell my reflection what an awful thing he did to the world. Look at what this Gayda said about the British yesterday, Bump!"

"You are still not bright," Bump Gillis sniffed. "Hitler is doin' all that in Germany and Mussolini is to blame for everythin' in Italy. Let's talk business."

"But Gayda is the Duce's mouth-piece," Phineas moaned. "This bird Laval sold out to Hitler, didn't he? I bet he is the same Frog who was Bugatti's angel that time. That was

Aero Book Reviews

Any volume described in this department may be obtained, at the price quoted, direct from the publisher named and at the address given. When writing for a book kindly mention that you saw it reviewed in FLYING ACES.

The Whole Story

Aviation From the Ground Up, by Lieut. G. B. Manly, Frederick J. Drake & Co., Chicago, Ill., \$3.00.

Here we have another technical book—the fourth to be reviewed this month—and it is quite similar in content to *General Aeronautics*. The only real difference is in the presentation of facts and material and the greater number of photographs included.

Aviation From the Ground Up is "a complete treatise on the fundamentals of all phases of aviation," according to the Drake Company. And we believe that they are very close to being correct in their contention, for every topic is discussed from the usual "History of Flight" to "Air Commerce Regulations" and "Aeronautical Words, Terms, and Definitions."

This book has been written for the average lay readers, presenting aviation technicalities in plain, everyday language, and steers away from complicated and difficult formulae and theories as much as possible.

How it Happened

The Story of Flying, by Archibald Black, Whittlesey House, McGraw-Hill Book Co., 330 West 42 Street, New York City, \$2.75.

One of the features of this book is its comparatively low price. Usually, volumes of this sort run anywhere from \$3.00 to \$4.75.

The Story of Flying is complete in every detail, even going back to the mythical days of Daedalus and Icarus to be sure that every phase of aviation's history is covered. It goes further, as a matter of fact, and even contains a chapter entitled, "Aircraft of Tomorrow." Book writers usually steer clear of being visionary in their works, but Mr. Black puts a new twist in the

old scheme and makes his final chapter very interesting.

Archibald Black, according to the book's jacket, has had personal experience in aviation dating back to 1910; and from 1915 to 1933 he devoted his time to aviation engineering. During the earlier part of this period he was on the staff of the Curtiss Company, the U. S. Navy Department, and others; later he served as a consultant to many large firms, specializing in air transport and related subjects. He has written two previous books on aviation, *Transport Aviation* and *Civil Airports and Airways*.

War in the Air

Armies With Wings, by James L. H. Peck, Dodd, Mead & Co., 449 Fourth Ave., New York City, \$2.50.

Frankly, we wish that book publishers would put out something once in a while that is not so good, for we've been saying books are excellent for so long that the change would actually be welcome. However, since they seem to know exactly what is wanted and the best way to present it, it seems that we'll just have to wait—probably in vain—for that not-so-good book.

Armies With Wings is another of those excellent volumes, and one that your reviewer is doubly happy to have in his collection. It breaks military flying down to its bare essentials and leaves it bare for the thorough inspection of the reader. The author carries through this breakdown by leading off with "Just What is an Air Force?" Then he follows through and answers his pointed question, which by itself sounds like a puzzler.

The book is divided into four parts and includes such chapters as, "Can Pilots Take it?" "Why Formation Flying?" and "Four Miles Down." As you might have guessed, the last mentioned chapter deals with test pilots—but good.

And for you fans who like photographs, there are plenty of them.

(Also see pages 64 and 72 for other reviews)

a swell crate, Bump, no matter what they said. Oh, sometimes it is almost too much for me to stand."

"I guess you will be at the reunion of old war aces in New York next Spring, huh?" Bump Gillis said.

"No!" Phineas Pinkham gulped out. "That is where the Bronx is, huh? I might meet a guy named Johnson and could not look him in the eye. I guess you heard about Philo being' one of the U. S. Army pilots and

who was forced to land just outside of Dayton yesterday? It is a nice girl Philo has in Dayton, Bump. It brings back memories, huh?"

"You are tellin' me," Mr. Donald Gillis, star salesman of Paramount Plastic Products, grinned at Phineas Pinkham. "Now this is just the right stuff I carry for them slugs. How about a couple of bolts of Gnylon to make them false faces, huh?"

THE END

FACTORY DOORS

(Continued from page 31)

gineers had developed a machine which will make riveting a faster, easier task.

THE MOST difficult part of a plane to build is the wing. These are constructed in special jigs in which the longitudinal members and spars are lined-up by the use of a surveyor's theodolite. Then the real work begins!

Ribs and flanged stringers are tediously placed in their respective positions and are covered with corrugated metal sheet. Internal aileron and flap controls are installed and the wiring system is strung up. Then the gas tank is lined and coated with bakelite cement to make it impervious to leakage and to prevent the metal skin from being affected by active chemicals in the gasoline. Following that, the outer skin is riveted on with precision.

SKYWRITING

(Continued from page 12)

on the vertical as some suppose. From below, this rather confusing technique is quite legible. To cross a "T" or make short bars of an "F," the pilot drops about fifty feet lower so that when making it he does not run into his previous smoke trail and disintegrate it with the propeller backwash. But from below, the completed letters seem to be all in one piece.

To complete a single message, a skywriter may have to travel as much as fifty miles. And if he forgets to dot an "I" or cross a "T," it means flying back five or ten miles to do so. The skywriter cannot see what he is doing since all the work is done at the same altitude, varying slightly only when he makes short or long right angle strokes. The letters are usually a mile long and a mile wide. After the job is done, the pilot dives a thousand feet or so and looks over his work. There's nothing that can be done about mistakes. You can't erase up there. If a flyer is conscious stricken about his error he'll blanket out the whole sign, fly off to another clear spot, and do the entire thing over again. Mistakes are very rare these days, but there have been some

While the wing is being fabricated, the fuselage shell is moving down the line. The bulkheads are connected by stringers and the skin is attached. The stationary tail surfaces are added and the inside of the body is then spray-painted. Following that, the instrument panel—or panels—are installed and wired up. The controls are hooked up, the turtle deck and sliding hatch are mounted, the motor mount and power plant is added, and the seat, radio, machine guns, ammunition boxes, and other units are put in their respective positions on the ship.

By this time, the wing is ready and is bolted to the fuselage flange angles or is attached to the center section stub panels. The landing gear is added, hooked up, and then the propeller, insignia, motor cowling, and other parts are put in place—and the ship is rolled through the factory doors for the ground crew to take over for final inspection and corrections before the test pilot takes the ship up on its initial hop.

THE END

real boners. They say you can't read a man's character by his skywriting—but you *can* get an idea as to how good a pilot he is.

A cloudless day and a blue sky are ideal for skywriting. The messages are seen best and from farthest points when written at an altitude between 12,000 and 15,000 feet. Usually, the air up there is pretty steady and the wind travels in one direction. And when the wind is just right, a message will sometimes be carried to distances of more than twenty miles and still remain intact.

Stinis once had the occasion of doing a writing at a Toronto exhibition and had the novel experience of viewing his own handiwork from the ground later. "It certainly must have lasted well over an hour, counting the time it took me to get back to earth and put my ship away and change my clothes," he said.

Skywriting is not without its humorous anecdotes, and there are several worth passing on.

"I was only once worried about the length of spelling a word," Stinis reminisced. "That was up in Boston where a walkathon contest was just about to end and we were under contract to write the name of the winner. His name was Michelavinski, or something like that."

Luckily, it rained that day so Andy

"America's Best"
FIREWORKS
COMPARE OUR PRICES BEFORE YOU BUY
One Cent POSTCARD will SAVE YOU MANY DOLLARS!

Send for NEW 1941 **FREE CATALOG** \$655 Liberty Bell ASSORTMENT
Over 1300 Pieces **\$2.85 NET**

FREE 100 Fort McHenry Salutes with orders of \$1.00 or more
Your Dollar Buys TWO Dollars Worth

BALTIMORE FIREWORKS CO., Inc.
6945 EASTERN AVE. BALTIMORE, MARYLAND

FLYING ACE BINOCULAR

\$1.98 Here is the glass you have been waiting for—a DeLuxe Binocular at a small price. Follow the planes, ships, and all ppd. sports. Highly polished, clear lenses; wide field; brilliant illumination. Center focus. Black enamel and leather covered. Open 4", closed 3 1/2". Neck strap with glass—\$1.98; with carrying case and straps—\$2.29. Send M.O.—Order yours TODAY!
Air Guns, Telescopes, Knives, Leather goods, etc.
LEE SALES CO. (Dept. AF), 35 W. 32nd St., N. Y. City

BIG CASH AWARDS FOR CAMERA FANS

Now is the time to get in on America's greatest hobby—amateur photography. Picture taking for readers of PRIZE PHOTOGRAPHY is twice as much fun. More than that—it's profitable. PRIZE PHOTOGRAPHY is the magazine for all picture takers. Here's why:

- ★ PRIZE PHOTOGRAPHY features five big picture-taking contests in every issue. Its exclusive pictorial articles tell you how to make good pictures. Simply follow the helpful tips these features contain and send in your pictures. You may win one of the many \$15, \$10 and \$5 prizes awarded each month.
- ★ PRIZE PHOTOGRAPHY is first in the latest developments in the camera world. Every issue is packed with interesting stories on photography at work in science, police work, the army, etc.
- ★ PRIZE PHOTOGRAPHY contains valuable tips for amateurs who develop and print their own pictures. Plans for building enlargers, handy gadgets for the darkroom, camera accessories, etc., are described in every issue.
- ★ PRIZE PHOTOGRAPHY contains hundreds of striking pictures and data on how they were made. This big rotogravure printed magazine is America's Greatest Photo Value. Rush to your nearest newsstand now. It's only 15 cents a copy.

PRIZE PHOTOGRAPHY

15c—AT ALL NEWSSTANDS—15c

GAS MOTOR \$4.95

Complete kit to build new Synoro Class "B" gas motor, all parts included. P.P. Including coil and condenser Complete.....\$5.95 P.P.

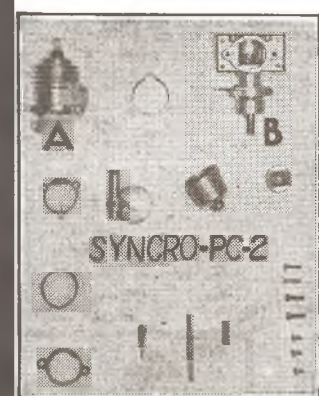

- Knocked down with Plan and Instructions
- Motor can be assembled and ready to run in 30 minutes.
 - LAPPED PISTON & CYLINDER
 - COUNTER BALANCED CRANK-SHAFT Fully Machined.
 - COMMUTATOR TYPE TIMER (No points to adjust)
 - Entire motor made of Aluminum alloy for lightness and strength

• Champion Spark Plug. All for \$4.95. This motor is designed thruout to give the maximum performance. Test motor was run 200 hours continuously without changing anything but the spark plug. Be the first to have this record breaker. This is the best buy of the year. Send for it now. IMMEDIATE DELIVERY.

MERCURY MODEL AIRPLANE CO.

1592-F.G. LINCOLN PL. BROOKLYN, N. Y.

BUYERS' DIRECTORY

Airplanes and Accessories, Schools—
Flying Instruction
\$5 per inch—Payable in Advance

PATENT ATTORNEY

PATENT YOUR IDEAS

send a Sketch or Model
of your invention for
CONFIDENTIAL
ADVISE
FREE CONSULTATION
LITERATURE

Z.P. Patlachek

NEW PATENT ATTORNEY
CONSULTATION
123-4 BROADWAY
NEW YORK
LONGACRE 5-3686

NAME.....
ADDRESS.....

CLASSIFIED DIRECTORY

Use this Directory for prompt response. Rate: 10c per word (minimum 20 words). CASH WITH ORDER. Make remittances payable to:
FLYING ACES
67 West 44th St., New York

AVIATION

AIRMINDED YOUNG MEN interested in training for entering the well-paid field of Aviation as Apprentices. See MUAS ad page 73.

BUILD WORLD FAMOUS WARSHIPS - RACE CARS AIRPLANES!

Complete Kits . . . No Extras to Buy!
See Your Dealer!
AIRCRAFT COMPANY, CHICAGO

Be A Detective

Make Secret Investigations

Earn Big Money. Work home or travel. Fascinating work. Experience unnecessary.
DETECTIVE Particulars FREE. Write
GEO. G. WAGNER, 2640 Broadway, N. Y.

DEALERS—CLUBS FREE LIQUIDS

In addition to our quality supplies and unsurpassed values, we offer you two

BIG—FREE DEALS

1. On all orders from \$2.50 to \$5.00, 1 qt. of A-1 cement or dope (add 25c for packing). 2. On all orders of \$5.00 or more, 1 gal. of A-1 cement or dope (add 75c for packing).

<p>BALSA WOOD 2 oz. . . . doz. 60c 36" Lengths Per 100 1/32x1/16 . . . 10c 1/16x1/16 . . . 10c 1/16x1/8 . . . 20c 1/16x3/16 . . . 25c 1/16x1/4 . . . 27c 3/32x3/32 . . . 25c 1/8x1/8 . . . 30c 1/8x3/16 . . . 35c 1/8x1/4 . . . 55c 1/4x1/4 . . . 65c 3/16x3/16 . . . 50c 3/16x1/4 . . . 60c 1/4x1/2 . . . 85c</p> <p>BALSA SHEETS 36" Lengths 1/64x2, 10 for 20c 1/32x2, 10 for 15c 1/16x2, 10 for 18c 3/32x2, 10 for 21c 1/8x2, 10 for 23c 3/16x2, 10 for 28c 1/4x2, 10 for 42c 1/2x2, 10 for 75c if 3" widths are desired, double price of 2" widths</p> <p>BALSA PLANKS 36" Lengths 1x1 each . . . 6c 1x1 1/2 each . . . 9c 1x2 each . . . 15c 1x3 each . . . 20c 1x6 each . . . 35c 1 1/2x1 1/2 each 25c 2x2 each . . . 25c 2x3 each . . . 35c</p> <p>CLEAR CEMENT 1 oz. bot. doz 38c 2 oz. bot. doz 65c 1 pt. 35c 1 qt. 65c 1 gal. . . . 1.75</p> <p>CLEAR DOPPE 1 oz. . . . doz. 36c</p>	<p>WASHERS 1/2 or 3/4, 100 5c Shafts or Rear Hooks . . . doz. 6c</p> <p>SHEET ALUM. -002 thick, 5' 35c -005 thick, 5' 50c -010 thick, 5' 75c</p> <p>ALUM. TUBING 1/16 O.D., 5' 25c 3/32 O.D., 5' 28c 1/8 O.D., 5' 30c 1/4 O.D., 5' 43c</p> <p>WIRE, per 100 ft. Straight Lengths No. 6 22c No. 8 27c No. 12 32c No. 14 37c</p> <p>BRASS BUSHINGS 1/16 dia. 100 12c 3/32 dia. 100 13c 1/8 dia. 100 18c</p> <p>SHEET CELLULOID 1 1/2x16, ea. 19c 6x8, doz. . . . 65c</p> <p>SPRING STEEL WIRE (In eye (5) foot Length) 1/16 dia. 15c 3/32 dia. 25c 1/8 dia. 30c 1/4 dia. 50c</p> <p>PNEUMATIC WHEELS For Gas Models With Valves 3 1/2" pair \$1.30 4 1/2" pair \$1.50</p>
--	---

MACHINE CUT PROPS, per doz.
5" . . . 20c 6" . . . 21c
7" . . . 30c 8" . . . 35c
10" . . . 45c 12" . . . 60c

M & M AIR WHEELS
(For rubber powered models)
1 1/4" 13c 1 1/2" 15c
1 3/4" 18c 2" 21c
2 1/4" 28c 2 1/2" 35c
2 3/4" 45c

THR. BEARING
sm. dz. 6c gr. 55c
lg. dz. 7c gr. 65c

PARA RUBBER
225 ft. skeins
1/8" dia. . . . 40c
3/16" dia. . . . 50c
Per lb. . . . \$1.10

**WE CARRY A FULL LINE OF
ALL MAKES MOTORS FOR
IMMEDIATE DELIVERY.
Motor Trades Accepted.**

Dealers send for Complete Catalog.
NO ORDERS UNDER \$2.50
Orders Shipped Express Charges Collect. On C.O.D. orders, send 25% with order, balance on delivery. Save C.O.D. charges, send payment with order.

MERCURY MODEL AIRPLANE CO.
1592-F.G. LINCOLN PLACE, BROOKLYN, N. Y.

didn't have to tie himself up in smoke knots to spell it.

The largest paid aerial advertisement ever written was "Fight Infantile Paralysis." The biggest single bit of on-their-own-hook writing was accomplished by three pilots—Stinis, Dave De Blasio and Cloyd Clevenger—on the dedication day of North Beach Airport. They wrote, "Name It LaGuardia Airport."

Then there's the one that took place back in the early days. One fellow who felt rather gay deliberately zoomed over a college campus and wrote "1+4=6!" And once an Army pilot somehow got hold of the right kind of smoke and adroitly wrote "Camels" every time the Skywriting Corp.'s ship wrote "Lucky Strike." The Skywriting Corp. which also handles banner towing, was paid to haul a banner over the Yale-Princeton game reading "Send Your Son to Harvard."

The best boner was about the pilot who actually got his chart backwards and, over a western city spelled out,

"Ydnac Tfol" five miles wide across the sky. The sponsor looked on in horror and threatened to cancel the contract immediately. But a representative of the Corp. pleaded with him to be patient and asked to give the pilot fifteen minutes. "He'll see his mistake," he assured the sponsor. The pilot did, and he flew a few miles away and wrote the entire ad over correctly and neatly.

The booby prize for boners, though, went to a pilot who wrote, "Air Sow" to advertise the New York Air Show of 1937. They still kid him about it today.

The most recent odd request concerned a minister who complained that his congregation seemed to prefer the beach to the benches. He asked if a sign could be towed across one of the more popular swimming resorts. It could, and when the sign billowed out it read: "Repent, for the Day of Reckoning Is Nigh." Next Sunday the entire congregation was back in church.

THE END

ME. FAME—?

(Continued from page 33)

The above tends to disprove definitely the "Fact" that the Hawk 75A is much superior to the Messerschmitt, but it does indicate that the British Spitfire is the better of the two fighters.

The armament of the 109 consists of a 23mm. cannon firing through the prop hub, the .312 caliber machine guns mounted in the cowl and synchronized to fire through the propeller, and a .318 machine gun in each wing outside the propeller arc. The wing span is so short that there is barely space for a machine gun and its ammunition box between the wheel well and the slot.

The latest Messerschmitt development, the twin-engine 110 fighter, is the only German plane which the British admit is better than any fighter they now have. The Me. 110

THE END

FINISH COUNTS

(Continued from page 46)

out as follows—one part pigmented dope to two parts thinner. Reason for this coat is to take out any brush marks that may be in the finish.

OUTDOOR GLIDERS
FORTUNATELY for the model building game, gliders have not gone out with the twin-pushers. (Editor's note: But the pushers haven't gone out, Frances, and we plan to publish drawings of this type shortly.) Gliders are really nice to fly, and they'll give better results if they have a slick finish. Aside from efficiency, additional strength is also acquired be-

cause the finish gives a thin, hard surface, and also tends to keep the adjustments longer. Damp weather will not harm the gliders because the finish is sort of weather proofing.

First, all the parts should be sanded with 7/0. Then they should be given two coats of clear dope. After the dope has dried resume sanding again so as to cut down the loose fibers and the swelling usually caused by doping. Two or three coats of glider polish should then be applied to all of the parts. These applications should be allowed to dry for the allotted time specified by the manufacturer. To finish off a tow-line glider the same procedure is used as on the rubber powered model.

To finish off any model plenty of elbow grease is needed.

THE END

COMET MAKES MOTOR HISTORY

The COMET 35

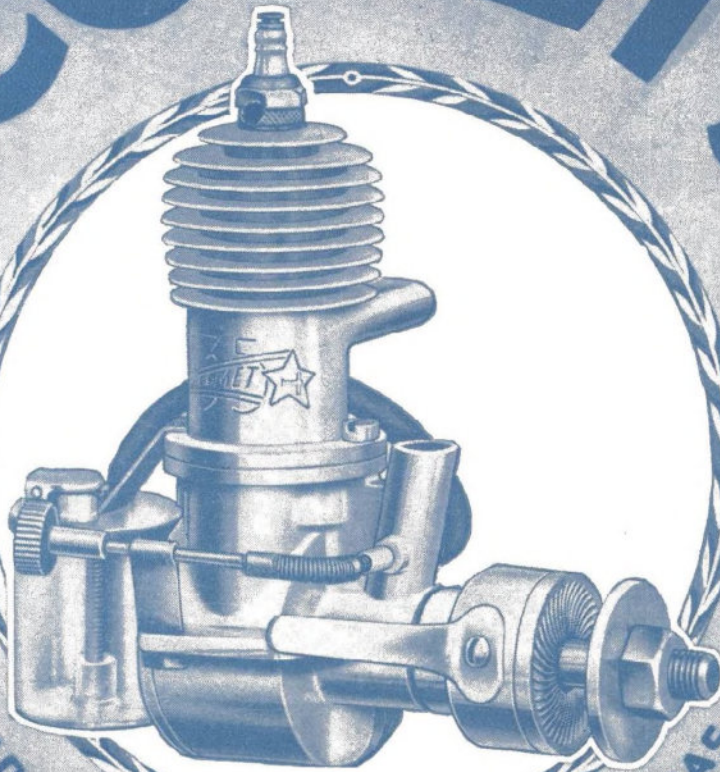

POWER
 Amazingly high ratio of power-to-size! Although the displacement is only 36 cu. in., the COMET "35" delivers 1.6 H.P. pulls 49 lbs. thrust, develops 6900 r.p.m. with a "13" prop. by stroboad test!

NO OTHER MOTOR IN CLASS "C" HAS SO MUCH POWER FOR THE SIZE

PERFORMANCE
 The power-for-displacement superiority of the COMET "35" is not guess work—it was definitely proven in tests conducted against the 3 most powerful Class "C" motors on the market. The chart tells the story!

DURABILITY

6 year accelerated service test, equivalent to 6 years of running on field, developed no appreciable signs of wear in a COMET "35" taken from stock. Built to endure, every part designed for long, trouble-free service!

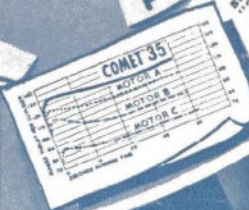

\$12⁹⁵

Complete with Smith coil, metal-clad condenser, deluxe run-in block and Motor Manual. Full written guarantee. Postage 50c; none if ordered from dealer.

A STATEMENT by CARL GOLDBERG

"Thrust tests I have run indicate that the COMET "35" has by far the most power for the size of any Class "C" motor on the market. Endurance tests covering the equivalent of 6 years of normal use reveal no appreciable wear on vital parts." *Carl Goldberg*

COMET MODEL AIRPLANE & SUPPLY CO., 129 W. 29th St., Chicago, Dept. FA-6, 688 Broadway, N. Y.

EVERYTHING THE GAS MODEL BUILDER NEEDS

When Megow came into the field, model airplane building was dependent entirely upon the ingenuity of the individual builder. Since that time, Megow has become a world-wide industry, so that scale and outline models of all kinds and sizes are available, and models of sensational new fighters and commercial planes follow closely upon the production of their prototypes.

Engines, sponge rubber wheels, propellers of all sizes, color-coded balsa wood, supplies and special tools have been made available through Megow dealers all over the country and in foreign lands, and for those not conveniently near a dealer, the Megow Catalog answers every need.

MODEL SHIPS. *The Megow Catalog contains scores of model ships, carved hulls and ready-made parts—everything needed by the builder of model ships.*

MODEL RAILROADS. *O and HO gauge locomotives, passenger and freight car kits, control equipment, rubber roadbed, track equipment, buildings and trackside equipment designed to scale.*



Send 10c for big, 132-page Catalog of Airplanes, Ships, Railroads, Parts and Supplies!



Ranger \$1.50



Holding National "Open" Record
Primarily a Class B, the RANGER is a Class A when used with the Megow 199 Motor shown here. Span 46". Wing area, 325 sq. in. Weight, ready to fly, 18½ oz. Complete with motor, wheels, propeller, flight timer and kit, \$15.75. Kit only, \$1.50. Motor only, \$12.50.

AeroChamp



New type designed to take the 199 motor shown above. Easy to build. Small, light and sturdy for safe landings. Span 46 in. Kit E-21, less wheels and propeller, 95c. Complete with motor, wheels, prop., kit and flight timer, \$14.95.

SOARING

Eagle

\$2.95



3-unit construction, easy to build, transport and fly. Marvelous in performance. Climbs at steep angle, flies without hanging on propeller. Low-mounted wing—no tendency to loop. Class A. 46" span, for any "A" motor. Fin. prop. \$2.95. Class B. 54" span, for any "B" motor. Fin. prop. \$3.95. Class C. 6 ft. span for any 1/5 h.p. motor. Fin. prop. and puncture-proof wheels, \$4.95.

MEGOW Streamlined Sponge Rubber WHEELS

Puncture-Proof. Very resilient.

2½ in. per pair, 45c. . . . 3½ in. 55c

X-ACTO Refill-Blade KNIVES—Interchangeable blades. Many types available.

No. 1. Small knife, 1 blade, 50c

No. 2. Large knife, 1 blade, 50c

5 extra blades, assorted or one style, 50c

ALL-METAL BATTERY HOLDERS—

For Penlites, 40c. For Medium Size Cells, 40c

For Standard Size Flashlight Cells . . . 50c

NEW Y-TYPE EXHAUST . . . \$1.50

Fits almost any ¼" motor.

"DG" PROPELLERS

9" to 14", 15c ea.

"WIZ" PROPELLERS

8" to 14", 25c ea.

BUILDING MEGOW PIPER CUB GAS MODEL

A beautiful model. Easy to build with Megow's ready-carved Leading Edge. Span 52¾". For any ¼" motor, \$3.95.

MEGOW
Dept FA.,
Philadelphia, Pennsylvania